

Chapter 5: Trigonometric Functions of Angles

In the previous chapters we have explored a variety of functions which could be combined to form a variety of shapes. In this discussion, one common shape has been missing: the circle. We already know certain things about the circle, like how to find area and circumference, and the relationship between radius and diameter, but now, in this chapter, we explore the circle and its unique features that lead us into the rich world of trigonometry.

Section 5.1 Circles	297
Section 5.2 Angles	307
Section 5.3 Points on Circles using Sine and Cosine.....	321
Section 5.4 The Other Trigonometric Functions	333
Section 5.5 Right Triangle Trigonometry.....	343

Section 5.1 Circles

To begin, we need to remember how to find distances. Starting with the Pythagorean Theorem, which relates the sides of a right triangle, we can find the distance between two points.

Pythagorean Theorem

The Pythagorean Theorem states that the sum of the squares of the legs of a right triangle will equal the square of the hypotenuse of the triangle.

In graphical form, given the triangle shown, $a^2 + b^2 = c^2$.

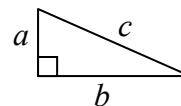

We can use the Pythagorean Theorem to find the distance between two points on a graph.

Example 1

Find the distance between the points $(-3, 2)$ and $(2, 5)$.

By plotting these points on the plane, we can then draw a right triangle with these points at each end of the hypotenuse. We can calculate horizontal width of the triangle to be 5 and the vertical height to be 3. From these we can find the distance between the points using the Pythagorean Theorem:

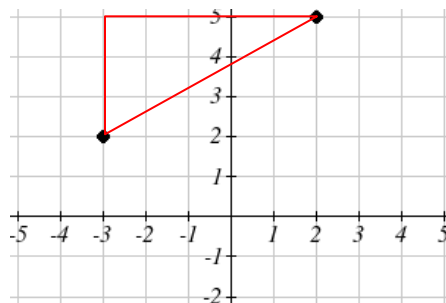

$$dist^2 = 5^2 + 3^2 = 34$$

$$dist = \sqrt{34}$$

Notice that the width of the triangle was calculated using the difference between the x (input) values of the two points, and the height of the triangle was found using the difference between the y (output) values of the two points. Generalizing this process gives us the general distance formula.

Distance Formula

The distance between two points (x_1, y_1) and (x_2, y_2) can be calculated as

$$dist = \sqrt{(x_2 - x_1)^2 + (y_2 - y_1)^2}$$

Try it Now

1. Find the distance between the points $(1, 6)$ and $(3, -5)$.

Circles

If we wanted to find an equation to represent a circle with a radius of r centered at a point (h, k) , we notice that the distance between any point (x, y) on the circle and the center point is always the same: r . Noting this, we can use our distance formula to write an equation for the radius:

$$r = \sqrt{(x - h)^2 + (y - k)^2}$$

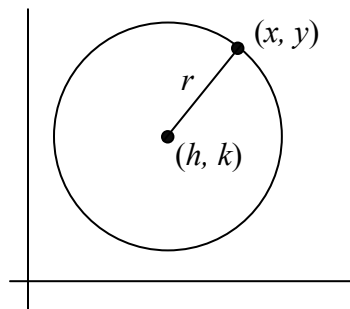

Squaring both sides of the equation gives us the standard equation for a circle.

Equation of a Circle

The **equation of a circle** centered at the point (h, k) with radius r can be written as

$$(x - h)^2 + (y - k)^2 = r^2$$

Notice that a circle does not pass the vertical line test. It is not possible to write y as a function of x or vice versa.

Example 2

Write an equation for a circle centered at the point $(-3, 2)$ with radius 4.

Using the equation from above, $h = -3$, $k = 2$, and the radius $r = 4$. Using these in our formula,

$$(x - (-3))^2 + (y - 2)^2 = 4^2 \quad \text{simplified a bit, this gives}$$

$$(x + 3)^2 + (y - 2)^2 = 16$$

Example 3

Write an equation for the circle graphed here.

This circle is centered at the origin, the point $(0, 0)$. By measuring horizontally or vertically from the center out to the circle, we can see the radius is 3. Using this information in our formula gives:

$$(x - 0)^2 + (y - 0)^2 = 3^2 \quad \text{simplified a bit, this gives}$$

$$x^2 + y^2 = 9$$

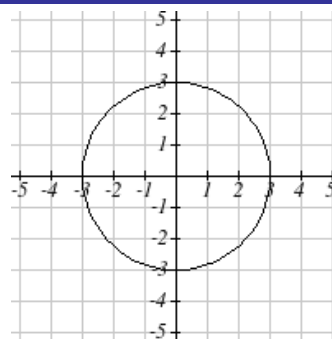
**Try it Now**

2. Write an equation for a circle centered at $(4, -2)$ with radius 6.

Notice that, relative to a circle centered at the origin, horizontal and vertical shifts of the circle are revealed in the values of h and k , which are the coordinates for the center of the circle.

Points on a Circle

As noted earlier, an equation for a circle cannot be written so that y is a function of x or vice versa. To find coordinates on the circle given only the x or y value, we must solve algebraically for the unknown values.

Example 4

Find the points on a circle of radius 5 centered at the origin with an x value of 3.

We begin by writing an equation for the circle centered at the origin with a radius of 5.

$$x^2 + y^2 = 25$$

Substituting in the desired x value of 3 gives an equation we can solve for y

$$3^2 + y^2 = 25$$

$$y^2 = 25 - 9 = 16$$

$$y = \pm\sqrt{16} = \pm 4$$

There are two points on the circle with an x value of 3: $(3, 4)$ and $(3, -4)$.

Example 5

Find the x intercepts of a circle with radius 6 centered at the point $(2, 4)$.

We can start by writing an equation for the circle.

$$(x - 2)^2 + (y - 4)^2 = 36$$

To find the x intercepts, we need to find the points where $y = 0$. Substituting in zero for y , we can solve for x .

$$(x - 2)^2 + (0 - 4)^2 = 36$$

$$(x - 2)^2 + 16 = 36$$

$$(x - 2)^2 = 20$$

$$x - 2 = \pm\sqrt{20}$$

$$x = 2 \pm \sqrt{20} = 2 \pm 2\sqrt{5}$$

The x intercepts of the circle are $(2 + 2\sqrt{5}, 0)$ and $(2 - 2\sqrt{5}, 0)$

Example 6

In a town, Main Street runs east to west, and Meridian Road runs north to south. A pizza store is located on Meridian 2 miles south of the intersection of Main and Meridian. If the store advertises that it delivers within a 3 mile radius, how much of Main Street do they deliver to?

This type of question is one in which introducing a coordinate system and drawing a picture can help us solve the problem. We could either place the origin at the intersection of the two streets, or place the origin at the pizza store itself. It is often easier to work with circles centered at the origin, so we'll place the origin at the pizza store, though either approach would work fine.

Placing the origin at the pizza store, the delivery area with radius 3 miles can be described as the region inside the circle described by $x^2 + y^2 = 9$. Main Street, located 2 miles north of the pizza store and running east to west, can be described by the equation $y = 2$.

To find the portion of Main Street the store will deliver to, we first find the boundary of their delivery region by looking for where the delivery circle intersects Main Street. To find the intersection, we look for the points on the circle where $y = 2$. Substituting $y = 2$ into the circle equation lets us solve for the corresponding x values.

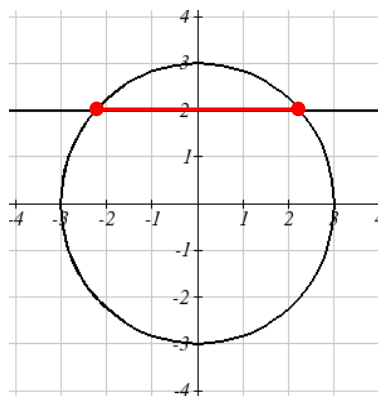

$$x^2 + 2^2 = 9$$

$$x^2 = 9 - 4 = 5$$

$$x = \pm\sqrt{5} \approx \pm 2.236$$

This means the pizza store will deliver 2.236 miles down Main Street east of Meridian and 2.236 miles down Main Street west of Meridian. We can conclude that the pizza store delivers to a 4.472 mile segment of Main St.

In addition to finding where a vertical or horizontal line intersects the circle, we can also find where an arbitrary line intersects a circle.

Example 7

Find where the line $f(x) = 4x$ intersects the circle $(x - 2)^2 + y^2 = 16$.

Normally, to find an intersection of two functions $f(x)$ and $g(x)$ we would solve for the x value that would make the function equal by solving the equation $f(x) = g(x)$. In the case of a circle, it isn't possible to represent the equation as a function, but we can utilize the same idea. The output value of the line determines the y value:

$y = f(x) = 4x$. We want the y value of the circle to equal the y value of the line, which is the output value of the function. To do this, we can substitute the expression for y from the line into the circle equation.

$$(x - 2)^2 + y^2 = 16 \quad \text{we replace } y \text{ with the line formula: } y = 4x$$

$$(x - 2)^2 + (4x)^2 = 16 \quad \text{expand}$$

$$x^2 - 4x + 4 + 16x^2 = 16 \quad \text{and simplify}$$

$$17x^2 - 4x + 4 = 16 \quad \text{since this equation is quadratic, we arrange one side to be 0}$$

$$17x^2 - 4x - 12 = 0$$

Since this quadratic doesn't appear to be easily factorable, we can use the quadratic formula to solve for x :

$$x = \frac{-(-4) \pm \sqrt{(-4)^2 - 4(17)(-12)}}{2(17)} = \frac{4 \pm \sqrt{832}}{34}, \text{ or approximately } x \approx 0.966 \text{ or } -0.731$$

From these x values we can use either equation to find the corresponding y values.

Since the line equation is easier to evaluate, we might choose to use it:

$$y = f(0.966) = 4(0.966) = 3.864$$

$$y = f(-0.731) = 4(-0.731) = -2.923$$

The line intersects the circle at the points $(0.966, 3.864)$ and $(-0.731, -2.923)$.

Try it Now

3. A small radio transmitter broadcasts in a 50 mile radius. If you drive along a straight line from a city 60 miles north of the transmitter to a second city 70 miles east of the transmitter, during how much of the drive will you pick up a signal from the transmitter?

Important Topics of This Section

Distance formula

Equation of a Circle

Finding the x coordinate of a point on the circle given the y coordinate or vice versa

Finding the intersection of a circle and a line

Try it Now Answers

1. $5\sqrt{5}$

2. $(x - 4)^2 + (y + 2)^2 = 36$

$x^2 + \left(60 - \frac{60}{70}x\right)^2 = 50^2$ gives $x = 14$ or $x = 45.29$, corresponding to points $(14, 48)$ and $(45.29, 21.18)$, resulting in a distance of 41.21 miles.

Section 5.1 Exercises

1. Find the distance between the points (5,3) and (-1,-5).
2. Find the distance between the points (3,3) and (-3,-2).
3. Write an equation of the circle centered at (8, -10) with radius 8.
4. Write an equation of the circle centered at (-9, 9) with radius 16.
5. Write an equation of the circle centered at (7, -2) that passes through (-10, 0).
6. Write an equation of the circle centered at (3, -7) that passes through (15, 13).
7. Write an equation for a circle where the points (2, 6) and (8, 10) lie along a diameter.
8. Write an equation for a circle where the points (-3, 3) and (5, 7) lie along a diameter.
9. Sketch a graph of $(x-2)^2 + (y+3)^2 = 9$.
10. Sketch a graph of $(x+1)^2 + (y-2)^2 = 16$.
11. Find the y intercept(s) of the circle with center (2, 3) with radius 3.
12. Find the x intercept(s) of the circle with center (2, 3) with radius 4.
13. At what point in the first quadrant does the line with equation $y=2x+5$ intersect a circle with radius 3 and center (0, 5)?
14. At what point in the first quadrant does the line with equation $y=x+2$ intersect the circle with radius 6 and center (0, 2)?
15. At what point in the second quadrant does the line with equation $y=2x+5$ intersect a circle with radius 3 and center (-2, 0)?
16. At what point in the first quadrant does the line with equation $y=x+2$ intersect the circle with radius 6 and center (-1,0)?
17. A small radio transmitter broadcasts in a 53 mile radius. If you drive along a straight line from a city 70 miles north of the transmitter to a second city 74 miles east of the transmitter, during how much of the drive will you pick up a signal from the transmitter?
18. A small radio transmitter broadcasts in a 44 mile radius. If you drive along a straight line from a city 56 miles south of the transmitter to a second city 53 miles west of the transmitter, during how much of the drive will you pick up a signal from the transmitter?

19. A tunnel connecting two portions of a space station has a circular cross-section of radius 15 feet. Two walkway decks are constructed in the tunnel. Deck A is along a horizontal diameter and another parallel Deck B is 2 feet below Deck A. Because the space station is in a weightless environment, you can walk vertically upright along Deck A, or vertically upside down along Deck B. You have been assigned to paint “safety stripes” on each deck level, so that a 6 foot person can safely walk upright along either deck. Determine the width of the “safe walk zone” on each deck. [UW]

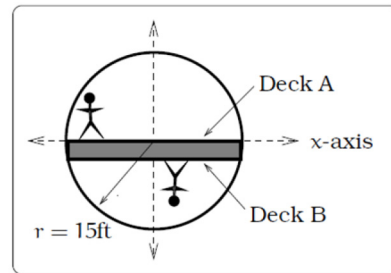

(a) Cross-section of tunnel.

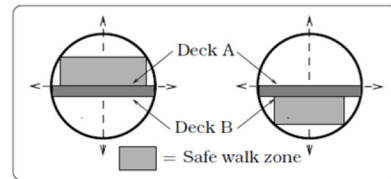

(b) Walk zones.

20. A crawling tractor sprinkler is located as pictured here, 100 feet south of a sidewalk. Once the water is turned on, the sprinkler waters a circular disc of radius 20 feet and moves north along the hose at the rate of $\frac{1}{2}$ inch/second. The hose is perpendicular to the 10 ft. wide sidewalk. Assume there is grass on both sides of the sidewalk. [UW]

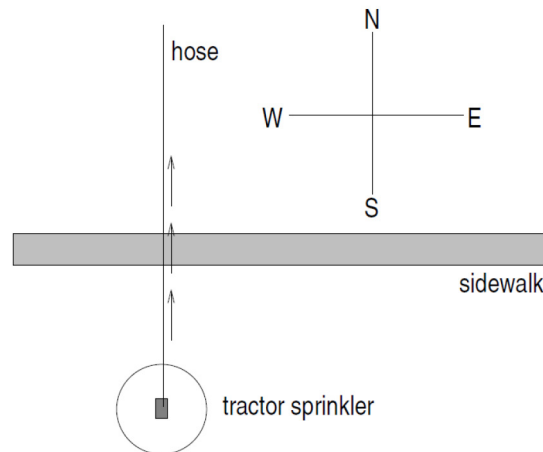

- Impose a coordinate system. Describe the initial coordinates of the sprinkler and find equations of the lines forming and find equations of the lines forming the north and south boundaries of the sidewalk.
- When will the water first strike the sidewalk?
- When will the water from the sprinkler fall completely north of the sidewalk?
- Find the total amount of time water from the sprinkler falls on the sidewalk.
- Sketch a picture of the situation after 33 minutes. Draw an accurate picture of the watered portion of the sidewalk.
- Find the area of grass watered after one hour.

21. Erik's disabled sailboat is floating anchored 3 miles East and 2 miles north of Kingston. A ferry leaves Kingston heading toward Edmonds at 12 mph. Edmonds is 6 miles due east of Kingston¹. After 20 minutes the ferry turns, heading due south. Ballard is 8 miles south and 1 mile west of Edmonds. Impose coordinates with Ballard as the origin. [UW]

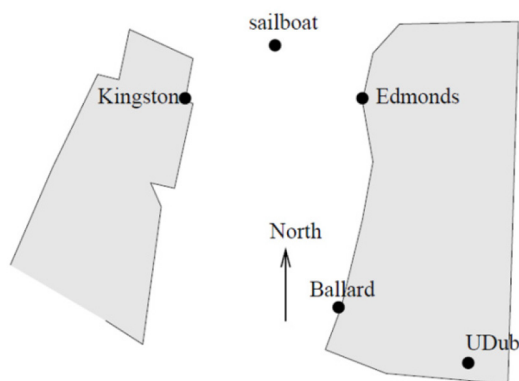

- Find equations for the lines along which the ferry is moving and draw in these lines.
- The sailboat has a radar scope that will detect any object within 3 miles of the sailboat. Looking down from above, as in the picture, the radar region looks like a circular disk. The boundary is the “edge” or circle around this disk, the interior is everything inside of the circle, and the exterior is everything outside of the circle. Give the mathematical description (an equation or inequality) of the boundary, interior and exterior of the radar zone. Sketch an accurate picture of the radar zone by determining where the line connecting Kingston and Edmonds would cross the radar zone.
- When does the ferry enter the radar zone?
- Where and when does the ferry exit the radar zone?
- How long does the ferry spend inside the radar zone?

¹ This is not actually true, sorry.

22. Nora spends part of her summer driving a combine during the wheat harvest. Assume she starts at the indicated position heading east at 10 ft/sec toward a circular wheat field of radius 200 ft. The combine cuts a swath 20 feet wide and begins when the corner of the machine labeled “a” is 60 feet north and 60 feet west of the westernmost edge of the field. [UW]

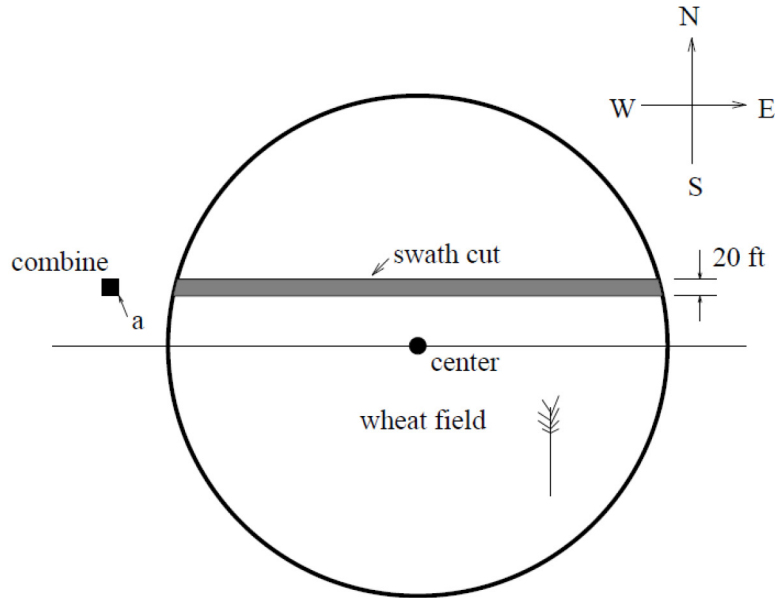

- a) When does Nora’s combine first start cutting the wheat?
 b) When does Nora’s combine first start cutting a swath 20 feet wide?
 c) Find the total amount of time wheat is being cut during this pass across the field.
 d) Estimate the area of the swath cut during this pass across the field.
23. The vertical cross-section of a drainage ditch is pictured to the right. Here, R indicates in each case the radius of a circle with $R = 10$ feet, where all of the indicated circle centers lie along a horizontal line 10 feet above and parallel to the ditch bottom. Assume that water is flowing into the ditch so that the level above the bottom is rising at a rate of 2 inches per minute. [UW]

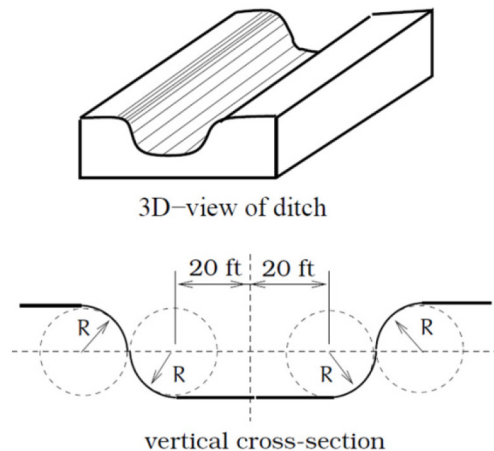

- a) When will the ditch be completely full?
 b) Find a piecewise defined function that models the vertical cross-section of the ditch.
 c) What is the width of the filled portion of the ditch after 1 hour and 18 minutes?
 d) When will the filled portion of the ditch be 42 feet wide? 50 feet wide? 73 feet wide?