

*Solutions Manual*

to

# **Precalculus**

An Investigation of Functions

David Lippman, Melonie Rasmussen

1<sup>st</sup> Edition

Shoreline Community College  
The Evergreen State College  
Edited by Rosalie Tepper

Copyright © 2013 Shoreline Community College and The Evergreen State College

This solutions manual was prepared by student tutors at Shoreline Community College and The Evergreen State College, and was edited by Rosalie Tepper.

Contributors include: Katie Gates, Maggie Arbeeny, Soren Wellman, Madeleine Beatty, Edward Lilley, Kalyani Loganathan, Matt Grove, John Lewis, George Marsh, Beinuo Gong, MyHuong Cao, Trent Linson, Kaitlyn Franz, and Lucas Kraft.

**This material is licensed under a Creative Commons Attribution-Noncommercial-ShareAlike 3.0 Unported License.**

To view a copy of this license, visit <http://creativecommons.org/licenses/by-nc-sa/3.0/> or send a letter to Creative Commons, 171 Second Street, Suite 300, San Francisco, California, 94105, USA.

You are **free**:

- to Share** — to copy, distribute, and transmit the work
- to Remix** — to adapt the work

Under the following conditions:

- Attribution.** You must attribute the work in the manner specified by the author or licensor (but not in any way that suggests that they endorse you or your use of the work).
- Noncommercial.** You may not use this work for commercial purposes.
- Share Alike.** If you alter, transform, or build upon this work, you may distribute the resulting work only under the same, similar or a compatible license.

With the understanding that:

- Waiver.** Any of the above conditions can be waived if you get permission from the copyright holder.
- Other Rights.** In no way are any of the following rights affected by the license:
  - Your fair dealing or fair use rights;
  - Apart from the remix rights granted under this license, the author's moral rights;
  - Rights other persons may have either in the work itself or in how the work is used, such as publicity or privacy rights.
  - Notice — For any reuse or distribution, you must make clear to others the license terms of this work. The best way to do this is with a link to this web page: <http://creativecommons.org/licenses/by-nc-sa/3.0/>

## Clarification

For the purposes of this work, the following uses are considered "NonCommercial."

- The use of this material at a for-profit institution or in a commercial company training course.
- Printing and distributing printed copies of this work through a print-on-demand site, where the price is set to the lowest allowed price.
- Printing and distributing printed copies through a college print shop or similar service, where the price is set to recover production costs. Normal book markup at the college bookstore is permissible.

## 1.1 Solutions to Exercises

1. (a)  $f(40) = 13$ , because the input 40 (in thousands of people) gives the output 13 (in tons of garbage)

(b)  $f(5) = 2$ , means that 5000 people produce 2 tons of garbage per week.

3. (a) In 1995 (5 years after 1990) there were 30 ducks in the lake.

(b) In 2000 (10 years after 1990) there were 40 ducks in the lake.

5. Graphs (a) (b) (d) and (e) represent  $y$  as a function of  $x$  because for every value of  $x$  there is only one value for  $y$ . Graphs (c) and (f) are not functions because they contain points that have more than one output for a given input, or values for  $x$  that have 2 or more values for  $y$ .

7. Tables (a) and (b) represent  $y$  as a function of  $x$  because for every value of  $x$  there is only one value for  $y$ . Table (c) is not a function because for the input  $x=10$ , there are two different outputs for  $y$ .

9. Tables (a) (b) and (d) represent  $y$  as a function of  $x$  because for every value of  $x$  there is only one value for  $y$ . Table (c) is not a function because for the input  $x=3$ , there are two different outputs for  $y$ .

11. Table (b) represents  $y$  as a function of  $x$  and is one-to-one because there is a unique output for every input, and a unique input for every output. Table (a) is not one-to-one because two different inputs give the same output, and table (c) is not a function because there are two different outputs for the same input  $x=8$ .

13. Graphs (b) (c) (e) and (f) are one-to-one functions because there is a unique input for every output. Graph (a) is not a function, and graph (d) is not one-to-one because it contains points which have the same output for two different inputs.

15. (a)  $f(1) = 1$

(b)  $f(3) = 1$

17. (a)  $g(2) = 4$

(b)  $g(-3) = 2$

19. (a)  $f(3) = 53$

(b)  $f(2) = 1$

21.  $f(-2) = 4 - 2(-2) = 4 + 4 = 8, f(-1) = 6, f(0) = 4, f(1) = 4 - 2(1) = 4 - 2 = 2, f(2) = 0$

$$23. f(-2) = 8(-2)^2 - 7(-2) + 3 = 8(4) + 14 + 3 = 32 + 14 + 3 = 49, f(-1) = 18, f(0) = 3, f(1) = 8(1)^2 - 7(1) + 3 = 8 - 7 + 3 = 4, f(2) = 21$$

$$25. f(-2) = -(-2)^3 + 2(-2) = -(-8) - 4 = 8 - 4 = 4, f(-1) = -(-1)^3 + 2(-1) = -(-1) - 2 = -1, f(0) = 0, f(1) = -(1)^3 + 2(1) = 1, f(2) = -4$$

$$27. f(-2) = 3 + \sqrt{(-2) + 3} = 3 + \sqrt{1} = 3 + 1 = 4, f(-1) = \sqrt{2} + 3 \approx 4.41, f(0) = \sqrt{3} + 3 \approx 4.73, f(1) = 3 + \sqrt{(1) + 3} = 3 + \sqrt{4} = 3 + 2 = 5, f(2) = \sqrt{5} + 3 \approx 5.23$$

$$29. f(-2) = ((-2) - 2)((-2) + 3) = (-4)(1) = -4, f(-1) = -6, f(0) = -6, f(1) = ((1) - 2)((1) + 3) = (-1)(4) = -4, f(2) = 0$$

$$31. f(-2) = \frac{(-2)-3}{(-2)+1} = \frac{-5}{-1} = 5, f(-1) = \text{undefined}, f(0) = -3, f(1) = -1, f(2) = -1/3$$

$$33. f(-2) = 2^{-2} = \frac{1}{2^2} = \frac{1}{4}, f(-1) = \frac{1}{2}, f(0) = 1, f(1) = 2, f(2) = 4$$

$$35. (a) -8$$

$$(b) -18$$

$$37. (a) f(0) = 5$$

$$(b) f\left(-\frac{5}{3}\right) = 0$$

$$39. (a) y = x \text{ (iii. Linear)}$$

$$(b) y = x^3 \text{ (viii. Cubic)}$$

$$(c) y = \sqrt[3]{x} \text{ (i. Cube Root)}$$

$$(d) y = \frac{1}{x} \text{ (ii. Reciprocal)}$$

$$(e) y = x^2 \text{ (vi. Quadratic)}$$

$$(f) y = \sqrt{x} \text{ (iv. Square Root)}$$

$$(g) y = |x| \text{ (v. Absolute Value)}$$

$$(h) y = \frac{1}{x^2} \text{ (vii. Reciprocal Squared)}$$

$$41. (a) y = x^2 \text{ (iv.)}$$

$$(b) y = x \text{ (ii.)}$$

$$(c) y = \sqrt{x} \text{ (v.)}$$

$$(d) y = \frac{1}{x} \text{ (i.)}$$

$$(e) y = |x| \text{ (vi.)}$$

$$(f) y = x^3 \text{ (iii.)}$$

$$43. (x - 3)^2 + (y + 9)^2 = (6)^2 \text{ or } (x - 3)^2 + (y + 9)^2 = 36$$

45. (a)

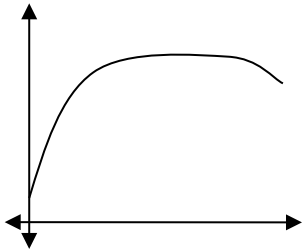

**Graph (a)**

At the beginning, as age increases, height increases. At some point, height stops increasing (as a person stops growing) and height stays the same as age increases. Then, when a person has aged, their height decreases slightly.

(b)

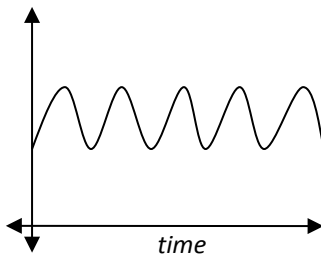

**Graph (b)**

As time elapses, the height of a person's head while jumping on a pogo stick as observed from a fixed point will go up and down in a periodic manner.

(c)

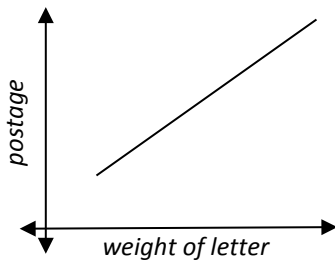

**Graph (c)**

The graph does not pass through the origin because you cannot mail a letter with zero postage or a letter with zero weight. The graph begins at the minimum postage and weight, and as the weight increases, the postage increases.

47. (a)  $t$       (b)  $x = a$       (c)  $f(b) = 0$  so  $z = 0$ . Then  $f(z) = f(0) = r$ .  
(d)  $L = (c, t), K = (a, p)$

## 1.2 Solutions to Exercises

1. The domain is  $[-5, 3]$ ; the range is  $[0, 2]$
3. The domain is  $2 < x \leq 8$ ; the range is  $6 \leq y < 8$
5. The domain is  $0 \leq x \leq 4$ ; the range is  $0 \leq y \leq -3$

7. Since the function is not defined when there is a negative number under the square root,  $x$  cannot be less than 2 (it can be equal to 2, because  $\sqrt{0}$  is defined). So the domain is  $x \geq 2$ . Because the inputs are limited to all numbers greater than 2, the number under the square root will always be positive, so the outputs will be limited to positive numbers. So the range is  $f(x) \geq 0$ .

9. Since the function is not defined when there is a negative number under the square root,  $x$  cannot be greater than 3 (it can be equal to 3, because  $\sqrt{0}$  is defined). So the domain is  $x \leq 3$ . Because the inputs are limited to all numbers less than 3, the number under the square root will always be positive, and there is no way for 3 minus a positive number to equal more than three, so the outputs can be any number less than 3. So the range is  $f(x) \leq 3$ .

11. Since the function is not defined when there is division by zero,  $x$  cannot equal 6. So the domain is all real numbers except 6, or  $\{x|x \in \mathbb{R}, x \neq 6\}$ . The outputs are not limited, so the range is all real numbers, or  $\{y \in \mathbb{R}\}$ .

13. Since the function is not defined when there is division by zero,  $x$  cannot equal  $-1/2$ . So the domain is all real numbers except  $-1/2$ , or  $\{x|x \in \mathbb{R}, x \neq -1/2\}$ . The outputs are not limited, so the range is all real numbers, or  $\{y \in \mathbb{R}\}$ .

15. Since the function is not defined when there is a negative number under the square root,  $x$  cannot be less than  $-4$  (it can be equal to  $-4$ , because  $\sqrt{0}$  is defined). Since the function is also not defined when there is division by zero,  $x$  also cannot equal 4. So the domain is all real numbers less than  $-4$  excluding 4, or  $\{x|x \geq -4, x \neq 4\}$ . There are no limitations for the outputs, so the range is all real numbers, or  $\{y \in \mathbb{R}\}$ .

17. It is easier to see where this function is undefined after factoring the denominator. This gives  $f(x) = \frac{x-3}{(x+11)(x-2)}$ . It then becomes clear that the denominator is undefined when  $x = -11$  and when  $x = 2$  because they cause division by zero. Therefore, the domain is  $\{x|x \in \mathbb{R}, x \neq -11, x \neq 2\}$ . There are no restrictions on the outputs, so the range is all real numbers, or  $\{y \in \mathbb{R}\}$ .

19.  $f(-1) = -4; f(0) = 6; f(2) = 20; f(4) = 24$

21.  $f(-1) = -1; f(0) = -2; f(2) = 7; f(4) = 5$

23.  $f(-1) = -5; f(0) = 3; f(2) = 3; f(4) = 16$

$$25. f(x) = \begin{cases} 2 & \text{if } -6 \leq x \leq -1 \\ -2 & \text{if } -1 < x \leq 2 \\ -4 & \text{if } 2 < x \leq 4 \end{cases} \quad 27. f(x) = \begin{cases} 3 & \text{if } x \leq 0 \\ x^2 & \text{if } x > 0 \end{cases}$$

$$29. f(x) = \begin{cases} 2x + 3 & \text{if } 3 \leq x < -1 \\ x - 1 & \text{if } -1 \leq x \leq 2 \\ -3 & \text{if } 2 < x \leq 5 \end{cases}$$

31.

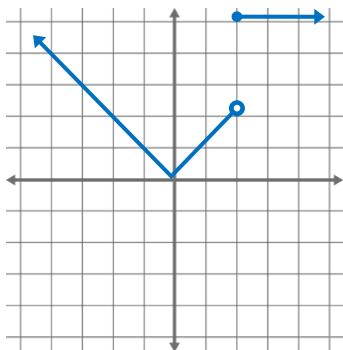

33.

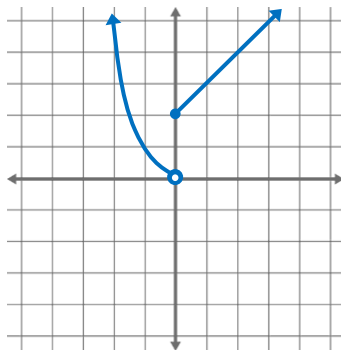

35.

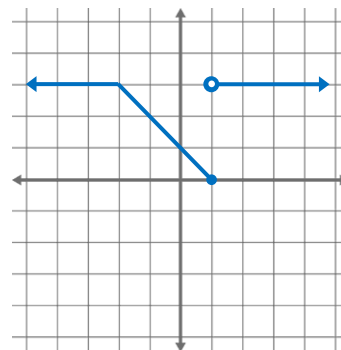

### 1.3 Solutions to Exercises

1. (a)  $\frac{249-243}{2002-2001} = \frac{6}{1} = 6$  million dollars per year

(b)  $\frac{249-243}{2004-2001} = \frac{6}{3} = 2$  million dollars per year

3. The inputs  $x = 1$  and  $x = 4$  produce the points on the graph:  $(4,4)$  and  $(1,5)$ . The average rate of change between these two points is  $\frac{5-4}{1-4} = \frac{1}{-3} = -\frac{1}{3}$ .

5. The inputs  $x = 1$  and  $x = 5$  when put into the function  $f(x)$  produce the points  $(1,1)$  and  $(5,25)$ . The average rate of change between these two points is  $\frac{25-1}{5-1} = \frac{24}{4} = 6$ .

7. The inputs  $x = -3$  and  $x = 3$  when put into the function  $g(x)$  produce the points  $(-3,82)$  and  $(3,80)$ . The average rate of change between these two points is  $\frac{80-82}{3-(-3)} = \frac{-2}{6} = -\frac{1}{3}$ .

9. The inputs  $t = -1$  and  $t = 3$  when put into the function  $k(t)$  produce the points  $(-1,2)$  and  $(3,54.148\bar{8})$ . The average rate of change between these two points is  $\frac{54.148-2}{3-(-1)} = \frac{52.148}{4} \approx 13$ .

11. The inputs  $x = 1$  and  $x = b$  when put into the function  $f(x)$  produce the points  $(1,-3)$  and  $(b,4b^2 - 7)$ . *Explanation:*  $f(1) = 4(1)^2 - 7 = -3$ ,  $f(b) = 4(b)^2 - 7$ . The average rate of

change between these two points is  $\frac{(4b^2-7)-(-3)}{b-1} = \frac{4b^2-7+3}{b-1} = \frac{4b^2-4}{b-1} = \frac{4(b^2-1)}{b-1} = \frac{4(b+1)(b-1)}{(b-1)} = 4(b+1)$ .

13. The inputs  $x = 2$  and  $x = 2 + h$  when put into the function  $h(x)$  produce the points  $(2,10)$  and  $(2 + h, 3h + 10)$ . *Explanation:*  $h(2) = 3(2) + 4 = 10$ ,  $h(2 + h) = 3(2 + h) + 4 = 6 + 3h + 4 = 3h + 10$ . The average rate of change between these two points is  $\frac{(3h+10)-10}{(2+h)-2} = \frac{3h}{h} = 3$ .

15. The inputs  $t = 9$  and  $t = 9 + h$  when put into the function  $a(t)$  produce the points  $(9, \frac{1}{13})$  and  $(9 + h, \frac{1}{h+13})$ . *Explanation:*  $a(9) = \frac{1}{9+4} = \frac{1}{13}$ ,  $a(9 + h) = \frac{1}{(9+h)+4} = \frac{1}{h+13}$ . The average rate of change between these two points is  $\frac{\frac{1}{h+13} - \frac{1}{13}}{(9+h)-9} = \frac{\frac{1}{h+13} - \frac{1}{13}}{h} = \left(\frac{1}{h+13} - \frac{1}{13}\right) \left(\frac{1}{h}\right) = \frac{1}{h(h+13)} - \frac{1}{13h} = \frac{1}{h^2+13h} - \frac{1}{13h} \left(\frac{\frac{h}{13}+1}{\frac{h}{13}+1}\right)$  (to make a common denominator)  $= \frac{1}{h^2+13h} - \left(\frac{\frac{h}{13}+1}{h^2+13h}\right) = \frac{1 - \frac{h}{13} - 1}{h^2+13h} = \frac{-\frac{h}{13}}{h^2+13h} = \frac{h}{13(h^2+13h)} = \frac{h}{13h(h+13)} = \frac{h}{13h(h+13)} = \frac{h}{13(h+13)}$ .

17. The inputs  $x = 1$  and  $x = 1 + h$  when put into the function  $j(x)$  produce the points  $(1,3)$  and  $(1 + h, 3(1 + h)^3)$ . The average rate of change between these two points is  $\frac{3(1+h)^3-3}{(1+h)-1} = \frac{3(1+h)^3-3}{h} = \frac{3(h^3+3h^2+3h+1)-3}{h} = \frac{3h^3+9h^2+9h+3-3}{h} = \frac{3h^3+9h^2+9h}{h} = 3h^2 + 9h + 9 = 3(h^2 + 3h + 3)$ .

19. The inputs  $x = x$  and  $x = x + h$  when put into the function  $f(x)$  produce the points  $(x, 2x^2 + 1)$  and  $(x + h, 2(x + h)^2 + 1)$ . The average rate of change between these two points is  $\frac{(2(x+h)^2+1)-(2x^2+1)}{(x+h)-x} = \frac{(2(x+h)^2+1)-(2x^2+1)}{h} = \frac{2(x+h)^2+1-2x^2-1}{h} = \frac{2(x+h)^2-2x^2}{h} = \frac{2(x^2+2hx+h^2)-2x^2}{h} = \frac{2x^2+4hx+2h^2-2x^2}{h} = \frac{4hx+2h^2}{h} = 4x + 2h = 2(2x + h)$ .

21. The function is increasing (has a positive slope) on the interval  $(-1.5,2)$ , and decreasing (has a negative slope) on the intervals  $(-\infty, -1.5)$  and  $(2, \infty)$ .



23. The function is increasing (has a positive slope) on the intervals  $(-\infty, 1)$  and  $(3.25, 4)$  and decreasing (has a negative slope) on the intervals  $(1, 2.75)$  and  $(4, \infty)$ .

25. The function is increasing because as  $x$  increases,  $f(x)$  also increases, and it is concave up because the rate at which  $f(x)$  is changing is also increasing.

27. The function is decreasing because as  $x$  increases,  $h(x)$  decreases. It is concave up because the rate at which  $h(x)$  is changing is increasing.

29. The function is decreasing because as  $x$  increases,  $f(x)$  decreases. It is concave up because the rate at which  $f(x)$  is changing is increasing (becoming less negative).

31. The function is increasing because as  $x$  increases,  $h(x)$  also increases (becomes less negative). It is concave down because the rate at which  $h(x)$  is changing is decreasing (adding larger and larger negative numbers).

33. The function is concave up on the interval  $(-\infty, 1)$ , and concave down on the interval  $(1, \infty)$ . This means that  $x = 1$  is a point of inflection (where the graph changes concavity).

35. The function is concave down on all intervals except where there is an asymptote at  $x \approx 3$ .

37. From the graph, we can see that the function is decreasing on the interval  $(-\infty, 3)$ , and increasing on the interval  $(3, \infty)$ . This means that the function has a local minimum at  $x = 3$ . We can estimate that the function is concave down on the interval  $(0, 2)$ , and concave up on the intervals  $(2, \infty)$  and  $(-\infty, 0)$ . This means there are inflection points at  $x = 2$  and  $x = 0$ .

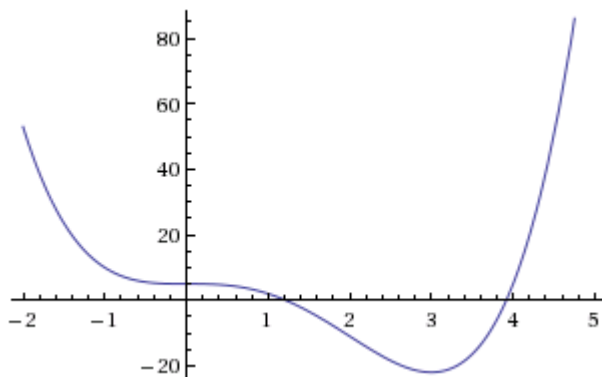

39. From the graph, we can see that the function is decreasing on the interval  $(-3, -2)$ , and increasing on the interval  $(-2, \infty)$ . This means that the function has a local minimum at  $x = -2$ . The function is always concave up on its domain,  $(-3, \infty)$ . This means there are no points of inflection.

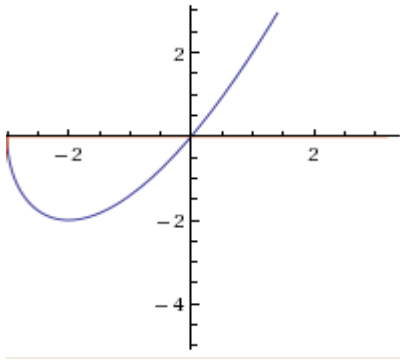

41. From the graph, we can see that the function is decreasing on the intervals  $(-\infty, -3.15)$  and  $(-0.38, 2.04)$ , and increasing on the intervals  $(-3.15, -0.38)$  and  $(2.04, \infty)$ . This means that the function has local minimums at  $x = -3.15$  and  $x = 2.04$  and a local maximum at  $x = -0.38$ . We can estimate that the function is concave down on the interval  $(-2, 1)$ , and concave up on the intervals  $(-\infty, -2)$  and  $(1, \infty)$ . This means there are inflection points at  $x = -2$  and  $x = 1$ .

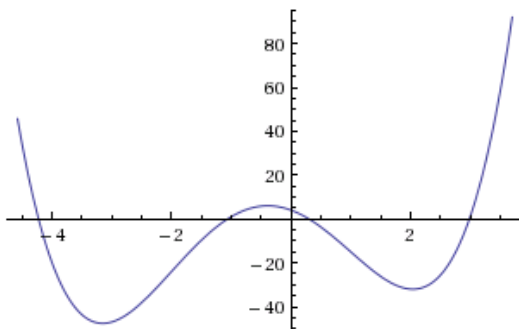

## 1.4 Solutions to Exercises

1.  $f(g(0)) = 4(7) + 8 = 26$ ,  $g(f(0)) = 7 - (8)^2 = -57$

3.  $f(g(0)) = \sqrt{(12) + 4} = 4$ ,  $g(f(0)) = 12 - (2)^3 = 4$

5.  $f(g(8)) = 4$

7.  $g(f(5)) = 9$

9.  $f(f(4)) = 4$

11.  $g(g(2)) = 7$

13.  $f(g(3)) = 0$

15.  $g(f(1)) = 4$

17.  $f(f(5)) = 3$

19.  $g(g(2)) = 2$

21.  $f(g(x)) = \frac{1}{\left(\frac{7}{x}+6\right)-6} = \frac{x}{7}, g(f(x)) = \frac{7}{\left(\frac{1}{x}-6\right)} + 6 = 7x - 36$

23.  $f(g(x)) = (\sqrt{x+2})^2 + 1 = x + 3, g(f(x)) = \sqrt{(x^2+1)+2} = \sqrt{(x^2+3)}$

25.  $f(g(x)) = |5x+1|, g(f(x)) = 5|x|+1$

27.  $f(g(h(x))) = \left((\sqrt{x}) - 6\right)^4 + 6$

29. (a)  $\frac{p(x)}{m(x)} = \frac{1}{\sqrt{x}x^2-4}$ , which can be written as  $\frac{1}{\sqrt{x}(x^2-4)}$ . This function is undefined when there is a negative number under the square root, or when the factor in the denominator equals zero. So the domain is all positive numbers excluding 2, or  $\{x|x > 0, x \neq 2\}$ .

(b)  $p(m(x)) = \frac{1}{\sqrt{x^2-4}}$ . This function is undefined when there is a negative number under the square root or a zero in the denominator, which happens when  $x$  is between -2 and 2. So the domain is  $-2 > x > 2$ .

(c)  $m(p(x)) = \left(\frac{1}{\sqrt{x}}\right)^2 - 4 = \frac{1}{x} - 4$ . This function is undefined when the denominator is zero, or when  $x = 0$ . So the domain is  $\{x|x \in \mathbb{R}, x \neq 0\}$ .

31. b

33. (a)  $r(V(t)) = \sqrt[3]{\frac{3(10+20t)}{4\pi}}$

(b) Evaluating the function in (a) when  $r(V(t)) = 10$  gives  $10 = \sqrt[3]{\frac{3(10+20t)}{4\pi}}$ . Solving this

for  $t$  gives  $t \approx 208.93$ , which means that it takes approximately 208 seconds or 3.3 minutes to blow up a balloon to a radius of 10 inches.

35.  $f(x) = x^2, g(x) = x + 2$

37.  $f(x) = \frac{3}{x}, g(x) = x - 5$

39.  $f(x) = 3 + x, g(x) = \sqrt{x - 2}$

41. (a)  $f(x) = ax + b$ , so  $f(f(x)) = a(ax + b) + b$ , which simplifies to  $a^2x + 2b$ .  $a$  and  $b$  are constants, so  $a^2$  and  $2b$  are also constants, so the equation still has the form of a linear function.

(b) If we let  $g(x)$  be a linear function, it has the form  $g(x) = ax + b$ . This means that  $g(g(x)) = a(ax + b) + b$ . This simplifies to  $g(g(x)) = a^2x + ab + b$ . We want  $g(g(x))$  to equal  $6x - 8$ , so we can set the two equations equal to each other:  $a^2x + ab + b = 6x - 8$ . Looking at the right side of this equation, we see that the thing in front of the  $x$  has to equal 6. Looking at the left side of the equation, this means that  $a^2 = 6$ . Using the same logic,  $ab + b = -8$ . We can solve for  $a = \sqrt{6}$ . We can substitute this value for  $a$  into the second equation to solve for  $b$ :  $(\sqrt{6})b + b = -8 \rightarrow b(\sqrt{6} + 1) = -8 \rightarrow b = -\frac{8}{\sqrt{6}+1}$ . So, since  $g(x) = ax + b$ ,  $g(x) = \sqrt{6}x - \frac{8}{\sqrt{6}+1}$ . Evaluating  $g(g(x))$  for this function gives us  $6x-8$ , so that confirms the answer.

43. (a) A function that converts seconds  $s$  into minutes  $m$  is  $m = f(s) = \frac{s}{60}$ .  $C(f(s)) = \frac{70(\frac{s}{60})^2}{10+(\frac{s}{60})^2}$ ; this function calculates the speed of the car in mph after  $s$  seconds.

(b) A function that converts hours  $h$  into minutes  $m$  is  $m = g(h) = 60h$ .  $C(g(h)) = \frac{70(60h)^2}{10+(60h)^2}$ ; this function calculates the speed of the car in mph after  $h$  hours.

(c) A function that converts mph  $s$  into ft/sec  $z$  is  $z = v(s) = \left(\frac{5280}{3600}\right)s$  which can be reduced to  $v(s) = \left(\frac{22}{15}\right)s$ .  $v(C(m)) = \left(\frac{22}{15}\right)\left(\frac{70m^2}{10+m^2}\right)$ ; this function converts the speed of the car in mph to ft/sec.

## 1.5 Solutions to Exercises

1. Horizontal shift 49 units to the right      3. Horizontal shift 3 units to the left

5. Vertical shift 5 units up

7. Vertical shift 2 units down

9. Horizontal shift 2 units to the right and vertical shift 3 units up

11.  $f(x) = \sqrt{x+2} + 1$

13.  $f(x) = \frac{1}{x-3} - 4$

15.  $g(x) = f(x-1)$ ,  $h(x) = f(x) + 1$

17.

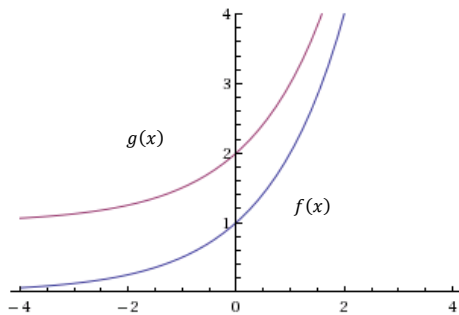

19.

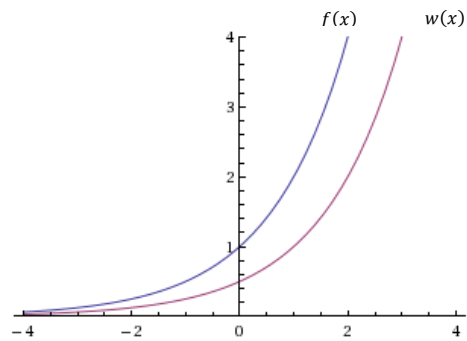

21.  $f(t) = (t+1)^2 - 3$  as a transformation of  $g(t) = t^2$

$f(t) = (t+1)^2 - 3$      $g(t) = t^2$

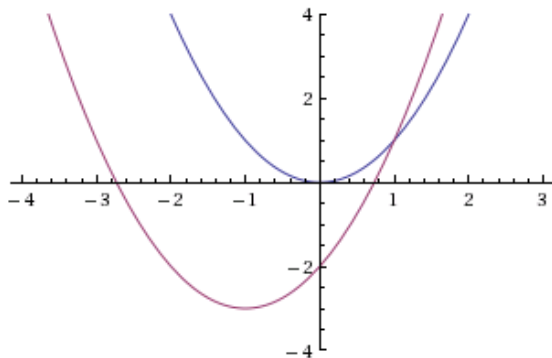

23.  $k(x) = (x - 2)^3 - 1$  as a transformation of  $f(x) = x^3$

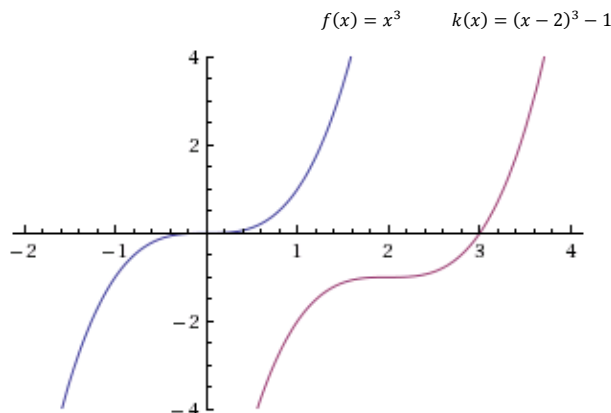

25.  $f(x) = |x - 3| - 2$

27.  $f(x) = \sqrt{x + 3} - 1$

29.  $f(x) = -\sqrt{x}$

31.

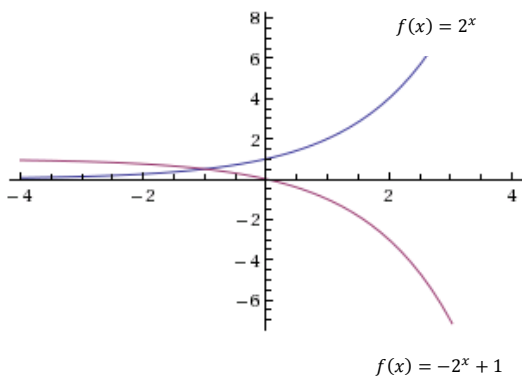

33. (a)  $f(x) = -6^{-x}$

(b)  $f(x) = -6^{x+2} - 3$

35.  $f(x) = -(x + 1)^2 + 2$

37.  $f(x) = \sqrt{-x} + 1$

39. (a) even

(b) neither

(c) odd

41. the function will be reflected over the x-axis

43. the function will be vertically stretched by a factor of 4

45. the function will be horizontally compressed by a factor of  $\frac{1}{5}$

47. the function will be horizontally stretched by a factor of 3

49. the function will be reflected about the y-axis and vertically stretched by a factor of 3

51.  $f(x) = |-4x|$

53.  $f(x) = \frac{1}{3(x+2)^2} - 3$

55.  $f(x) = (2[x - 5])^2 + 1 = (2x - 10)^2 + 1$

57.  $f(x) = x^2$  will be shifted to the left 1 unit, vertically stretched by a factor of 4, and shifted down 5 units.

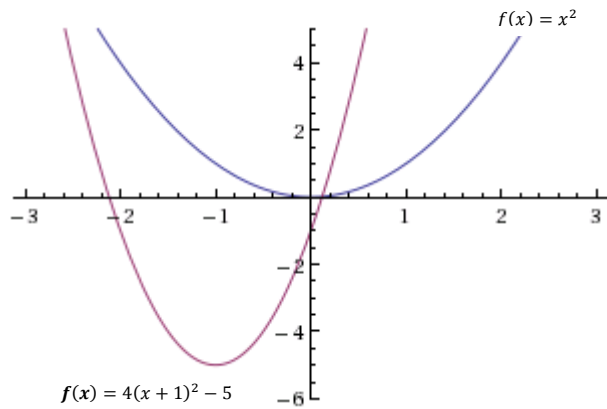

59.  $h(x) = |x|$  will be shifted right 4 units vertically stretched by a factor of 2, reflected about the x-axis, and shifted up 3 units.

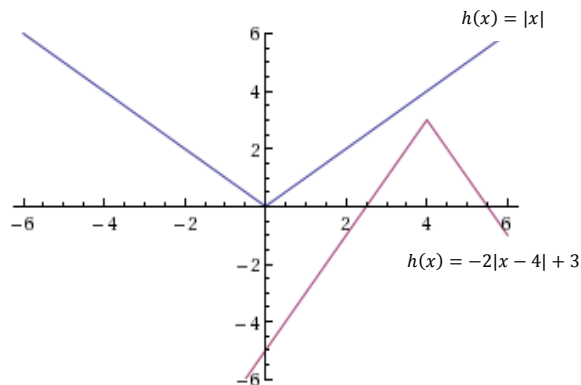

61.  $m(x) = x^3$  will be vertically compressed by a factor of  $\frac{1}{2}$ .

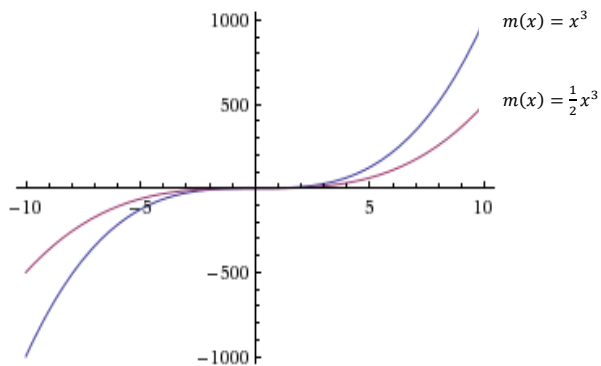

63.  $p(x) = x^2$  will be stretched horizontally by a factor of 3, and shifted down 3 units.

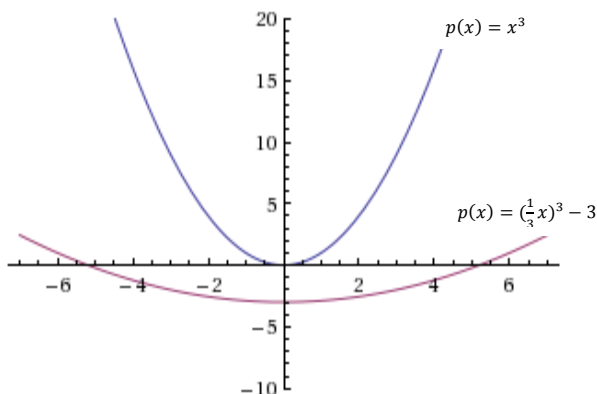

65.  $a(x) = \sqrt{x}$  will be shifted left 4 units and then reflected about the y-axis.

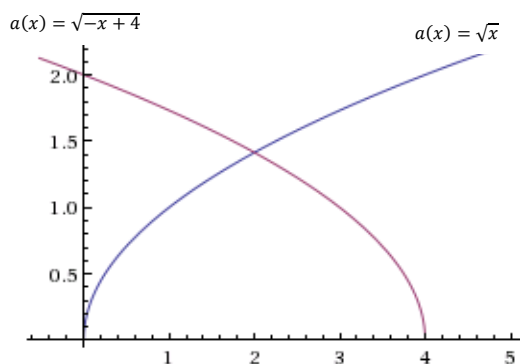

67. the function is decreasing on the interval  $x < -1$  and increasing on the interval  $x > -1$

69. the function is decreasing on the interval  $x \leq 4$

71. the function is concave up on the interval  $x < -1$  and concave down on the interval  $x > -1$

73. the function is always concave up.

75.  $f(-x)$

77.  $3f(x)$

79.  $2f(-x)$

81.  $2f\left(\frac{1}{2}x\right)$

83.  $2f(x) - 2$

85.  $-f(x) + 2$

87.  $f(x) = -(x + 2)^2 + 3$

89.  $f(x) = \frac{1}{2}(x + 1)^3 + 2$

91.  $f(x) = \sqrt{2(x + 2)} + 1$

93.  $f(x) = -\frac{1}{(x-2)^2} + 3$



95.  $f(x) = -|x + 1| + 3$
97.  $f(x) = -(x - 2)^{\frac{1}{3}} + 1$
99. (a) With the input in factored form, we first apply the horizontal compression by a factor of  $\frac{1}{2}$ , followed by a shift to the right by three units. After applying the horizontal compression, the domain becomes  $\frac{1}{2} \leq x \leq 3$ . Then we apply the shift, to get a domain of  $\{x \mid 3\frac{1}{2} \leq x \leq 6\}$ .
- (b) Since these are horizontal transformations, the range is unchanged.
- (c) These are vertical transformations, so the domain is unchanged.
- (d) We first apply the vertical stretch by a factor of 2, followed by a downward shift of three units. After the vertical stretch, the range becomes  $-6 \leq y \leq 10$ . Next, we apply the shift to get the final domain  $\{y \mid -9 \leq y \leq 7\}$ .
- (e) The simplest solution uses a positive value of  $B$ . The new domain is an interval of length one. Before, it was an interval of length 5, so there has been a horizontal compression by a factor of  $\frac{1}{5}$ . Therefore,  $B = 5$ . If we apply this horizontal compression to the original domain, we get  $\frac{1}{5} \leq x \leq \frac{6}{5}$ . To transform this interval into one that starts at 8, we must add  $7\frac{4}{5} = \frac{39}{5}$ . This is our rightward shift, so  $c = \frac{39}{5}$ .
- (f) The simplest solution uses a positive value of  $A$ . The new range is an interval of length one. The original range was an interval of length 8, so there has been a vertical compression by a factor of  $\frac{1}{8}$ . Thus, we have  $A = \frac{1}{8}$ . If we apply this vertical compression to the original range we get  $\frac{3}{8} \leq y \leq \frac{5}{8}$ . Now, in order to get an interval that begins at 0, we must add  $\frac{3}{8}$ . This is a vertical shift upward, and we have  $D = \frac{3}{8}$ .

## 1.6 Solutions to Exercises

- The definition of the inverse function is the function that reverses the input and output. So if the output is 7 when the input is 6, the inverse function  $f^{-1}(x)$  gives an output of 6 when the input is 7. So,  $f^{-1}(7) = 6$ .
- The definition of the inverse function is the function which reverse the input and output of the original function. So if the inverse function  $f^{-1}(x)$  gives an output of  $-8$  when the input is  $-4$ ,

the original function will do the opposite, giving an output of  $-4$  when the input is  $-8$ . So  $f(-8) = -4$ .

5.  $f(5) = 2$ , so  $(f(5))^{-1} = (2)^{-1} = \frac{1}{2^1} = \frac{1}{2}$ .

7. (a)  $f(0) = 3$

(b) Solving  $f(x) = 0$  asks the question: for what input is the output 0? The answer is  $x = 2$ . So,  $f(2) = 0$ .

(c) This asks the same question as in part (b). When is the output 0? The answer is  $f^{-1}(0) = 2$ .

(d) The statement from part (c)  $f^{-1}(0) = 2$  can be interpreted as “in the original function  $f(x)$ , when the input is 2, the output is 0” because the inverse function reverses the original function. So, the statement  $f^{-1}(x) = 0$  can be interpreted as “in the original function  $f(x)$ , when the input is 0, what is the output?” the answer is 3. So,  $f^{-1}(3) = 0$ .

9. (a)  $f(1) = 0$

(b)  $f(7) = 3$

(c)  $f^{-1}(0) = 1$

(d)  $f^{-1}(3) = 7$

11.

$x$	1	4	7	12	16
$f^{-1}(x)$	3	6	9	13	14

13. The inverse function takes the output from your original function and gives you back the input, or undoes what the function did. So if  $f(x)$  adds 3 to  $x$ , to undo that, you would subtract 3 from  $x$ . So,  $f^{-1}(x) = x - 3$ .

15. In this case, the function is its own inverse, in other words, putting an output back into the function gives back the original input. So,  $f^{-1}(x) = 2 - x$ .

17. The inverse function takes the output from your original function and gives you back the input, or undoes what the function did. So if  $f(x)$  multiplies 11 by  $x$  and then adds 7, to undo that, you would subtract 7 from  $x$ , and then divide by 11. So,  $f^{-1}(x) = \frac{x-7}{11}$ .

19. This function is one-to-one and non-decreasing on the interval  $x > -7$ . The inverse function, restricted to that domain, is  $f^{-1}(x) = \sqrt{x} - 7$ .

21. This function is one-to-one and non-decreasing on the interval  $x > 0$ . The inverse function, restricted to that domain, is  $f^{-1}(x) = \sqrt{x + 5}$ .

23. (a)  $f(g(x)) = \left(\sqrt[3]{x + 5}\right)^3 - 5$ , which just simplifies to  $x$ .

(b)  $g(f(x)) = \left(\sqrt[3]{(x^3 - 5) + 5}\right)$ , which just simplifies to  $x$ .

(c) This tells us that  $f(x)$  and  $g(x)$  are inverses, or, they undo each other.

## 2.1 Solutions to Exercises

1.  $P(t) = 1700t + 45,000$

3.  $D(t) = 2t + 10$

5. Timmy will have the amount  $A(n)$  given by the linear equation  $A(n) = 40 - 2n$ .

7. From the equation, we see that the slope is 4, which is positive, so the function is increasing.

9. From the equation, we see that the slope is  $-2$ , which is negative, so the function is decreasing.

11. From the equation, we see that the slope is  $-2$ , which is negative, so the function is decreasing.

13. From the equation, we see that the slope is  $\frac{1}{2}$ , which is positive, so the function is increasing.

15. From the equation, we see that the slope is  $-\frac{1}{3}$ , which is negative, so the function is decreasing.

17.  $m = \frac{10-4}{4-2} = \frac{6}{2} = 3$ .

19.  $m = \frac{2-4}{5-(-1)} = \frac{-2}{6} = -\frac{1}{3}$

21.  $m = \frac{3-11}{-4-6} = \frac{-8}{-10} = \frac{4}{5}$

23.  $m = \frac{2}{3}$

25.  $m = \frac{1.4-0.9}{12-2} = \frac{0.5 \text{ miles}}{10 \text{ minutes}} = \frac{.005 \text{ miles}}{1 \text{ minute}}$

27.  $m = \frac{275,900-287,500}{1989-1960} = \frac{-11,600 \text{ people}}{29 \text{ years}} = \frac{-400 \text{ people}}{\text{year}}$ . The negative rate means that the population is declining by approximately 400 people per year.

29. The rate is equal to the slope, which is 0.1. The initial value is the y-intercept, which is 24. This means that the phone company charges 0.1 dollars per minute, or 10 cents a minute, plus an additional fixed 24 dollars per month.

31. Terry starts skiing at 3000 feet, and skis downhill at a constant rate of 70 feet per second.

33. From this information we can extract two ordered pairs,  $(-5, -4)$  and  $(5, 2)$ . The slope between these two points is  $m = \frac{2 - (-4)}{5 - (-5)} = \frac{6}{10} = \frac{3}{5}$ . This gives us the formula  $f(x) = \frac{3}{5}x + b$ . To find the y-intercept  $b$ , we can substitute one of our ordered pairs into the equation for  $f(x)$  and  $x$ . For example:  $2 = \frac{3}{5}(5) + b$ . Solving for  $b$  gives us  $b = -1$ . So, the final equation is  $f(x) = \frac{3}{5}x - 1$ .

35. The slope between these two points is  $m = \frac{10 - 4}{4 - 2} = \frac{6}{2} = 3$ . This gives us the formula  $f(x) = 3x + b$ . To find the y-intercept  $b$ , we can substitute one of our ordered pairs into the equation for  $f(x)$  and  $x$ . For example:  $4 = 3(2) + b$ . Solving for  $b$  gives us  $b = -2$ . So, the final equation is  $f(x) = 3x - 2$ .

37. The slope between these two points is  $m = \frac{2 - 4}{5 - (-1)} = \frac{-2}{6} = -\frac{1}{3}$ . This gives us the formula  $f(x) = -\frac{1}{3}x + b$ . To find the y-intercept  $b$ , we can substitute one of our ordered pairs into the equation for  $f(x)$  and  $x$ . For example:  $2 = -\frac{1}{3}(5) + b$ . Solving for  $b$  gives us  $b = \frac{11}{3}$ . So, the final equation is  $f(x) = -\frac{1}{3}x + \frac{11}{3}$ .

39. The slope between these two points is  $m = \frac{-3 - 0}{0 - (-2)} = \frac{-3}{2} = -\frac{3}{2}$ . We are given the y-intercept  $b = -3$ . So, the final equation is  $f(x) = -\frac{3}{2}x - 3$ .

41.  $f(x) = \frac{2}{3}x + 1$

43.  $f(x) = -2x + 3$

45. From this information we can extract two ordered pairs,  $(1000, 30)$  and  $(3000, 22)$ . The slope between these two points is  $m = \frac{22 - 30}{3000 - 1000} = \frac{-8}{2000} = -\frac{1}{250}$ . This gives us the formula  $f(x) = -\frac{1}{250}x + b$ . To find the y-intercept  $b$ , we can substitute one of our ordered pairs into the equation for  $f(x)$  and  $x$ . For example:  $30 = -\frac{1}{250}(1000) + b$ . Solving for  $b$  gives us  $b = 34$ . So, the final equation is  $f(x) = -\frac{1}{250}x + 34$ .

47. (a) Linear, because  $x$  is changing at a constant rate, and  $g(x)$  is also changing at a constant rate. The output is changing by  $-15$ , and the input is changing by  $5$ . So, the rate of change is  $-\frac{15}{5} = -3$ . The y-intercept is given from the table as the ordered pair  $(0,5)$ , so  $b = 5$ . So, the final equation is  $g(x) = -3x + 5$ .

(b) Not linear, because  $h(x)$  is not increasing a constant rate.

(c) Linear, because  $x$  is changing at a constant rate, and  $f(x)$  is also changing at a constant rate. The output is changing by  $25$ , and the input is changing by  $5$ . So, the rate of change is  $\frac{25}{5} = 5$ . The y-intercept is given from the table as the ordered pair  $(0,-5)$ , so  $b = -5$ . So, the final equation is  $f(x) = 5x - 5$ .

(d) Not linear, because  $k(x)$  is not increasing a constant rate.

49. (a) From this information we can extract two points,  $(32,0)$  and  $(212,100)$  using  $F$  as the input and  $C$  as the output. The slope between these two points is  $m = \frac{100-0}{212-32} = \frac{100}{180} = \frac{10}{18} = \frac{5}{9}$ .

This gives us the formula  $C(F) = \frac{5}{9}F + b$ . To find the y-intercept  $b$ , we can substitute one of our ordered pairs into the equation. For example:  $0 = \frac{5}{9}(32) + b$ . Solving for  $b$  gives us  $b = -\frac{160}{9}$ . So, the final equation is  $C = \frac{5}{9}F - \frac{160}{9}$ .

(b) This can be done by solving the equation we found in part (a) for  $F$  instead of  $C$ . So,

$$F = \frac{9}{5}\left(C + \frac{160}{9}\right).$$

(c) To find  $-23$  C in Fahrenheit, we plug it into this equation for  $C$  and solve for  $F$ , giving us  $F = -9.3$  degrees F

## 2.2 Solutions to Exercises

1. E

3. D

5. B

7.  $f(x) = -\frac{1}{2}x - 2$

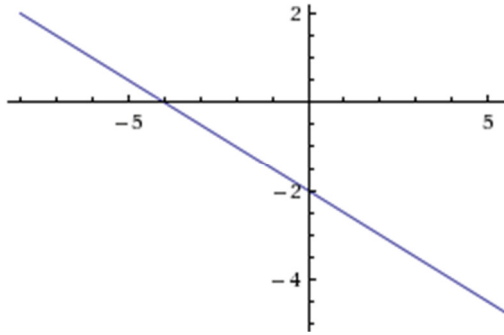

9.  $f(x) = -\frac{3}{2}x + 7$

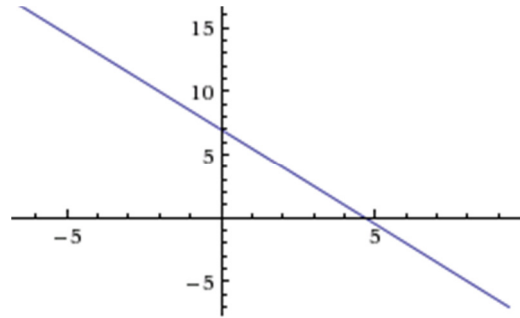

11.  $f(x) = -\frac{1}{3}x - 4$

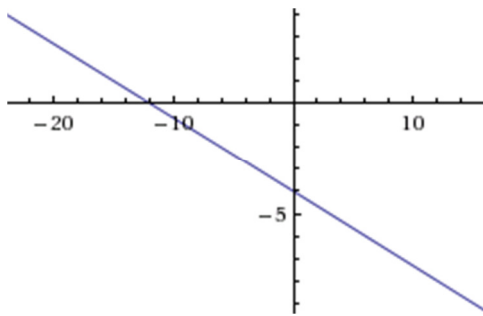

13.  $f(x) = -2x - 1$

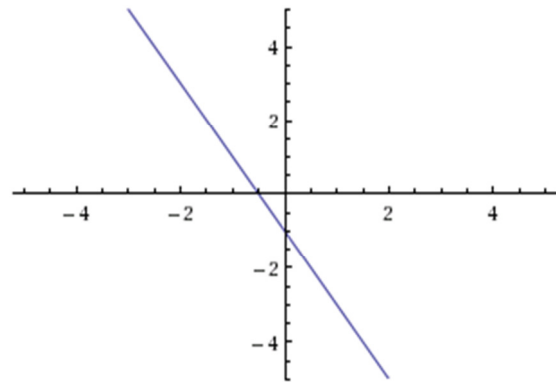

15.  $h(x) = \frac{1}{3}x + 2$

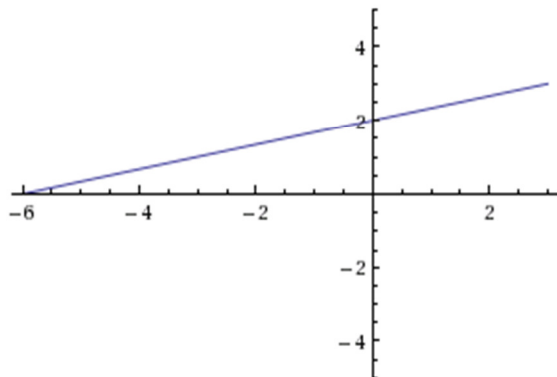

17.  $k(t) = 3 + 2t$

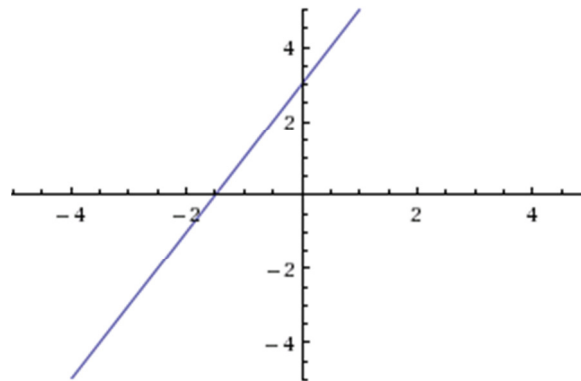

19.  $x = 3$

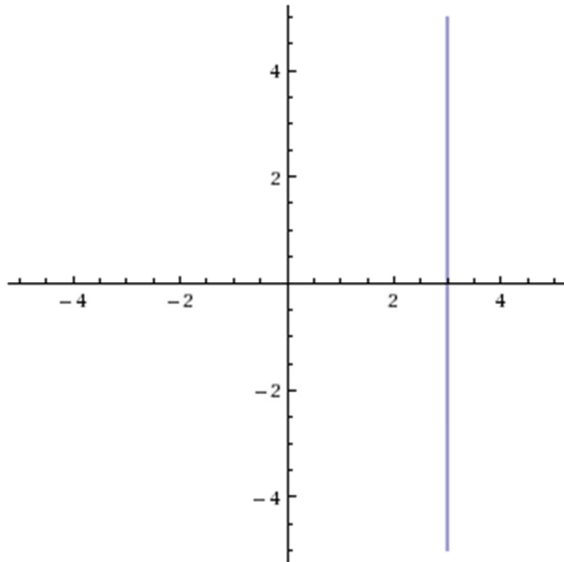

21.  $r(x) = 4$

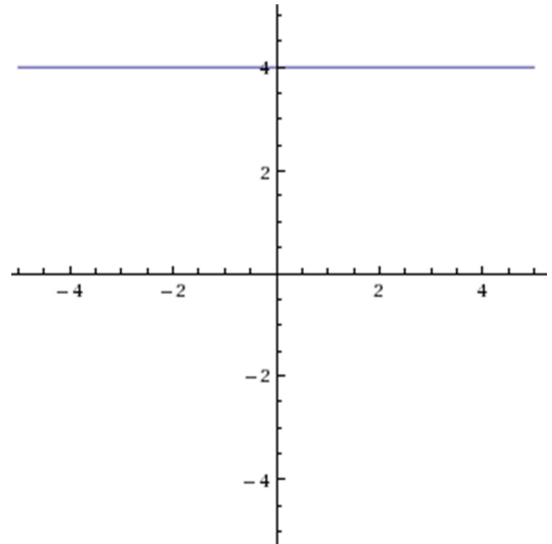

23. (a)  $g(x) - 4 = \frac{3}{4}x + 2$  or  $g(x) = \frac{3}{4}x + 6$

(b)  $m = \frac{3}{4}$

(c)  $b = 6$

25.  $f(x) = 3$

27.  $x = -3$

29. Horizontal intercept (when  $f(x) = 0$ ) =  $-2$ , vertical intercept (when  $x = 0$ ) =  $2$ .

31. Horizontal intercept (when  $f(x) = 0$ ) =  $\frac{5}{3}$ , vertical intercept (when  $x = 0$ ) =  $-5$ .

33. Horizontal intercept (when  $f(x) = 0$ ) =  $-10$ , vertical intercept (when  $x = 0$ ) =  $4$

35. Slope of line 1 =  $-10$ , Slope of line 2 =  $-10$ . They have the same slope, so they are parallel.

37. Slope of line 1 =  $-\frac{1}{2}$ , Slope of line 2 =  $1$ . They are neither perpendicular or parallel.

39. Slope of line 1 =  $-\frac{2}{3}$ , Slope of line 2 =  $\frac{3}{2}$ . The product of the two slopes is  $-1$ , so they are perpendicular.

41. A line parallel to  $f(x)$  has the same slope of  $-5$ . So its equation has the form  $f(x) = -5x + b$ . Plugging in the given point  $(2, -12)$  allows us to solve for  $b$ , which equals  $22$ . So, the final equation is  $y = -5x + 22$ .



43. A line perpendicular to  $h(t)$  has a slope which is the opposite reciprocal of  $-2$ , which is  $\frac{1}{2}$ . So its equation has the form  $f(x) = \frac{1}{2}x + b$ . Plugging in the given point  $(-4,1)$  allows us to solve for  $b$ , which equals 3. So, the final equation is  $y = \frac{1}{2}x + 3$ .

45. At the point where the two lines intersect, they will have the same  $y$  value, so we can set  $f(x)$  and  $g(x)$  equal to each other. So,  $-2x - 1 = -x$ . Solving for  $x$  gives  $x = -1$ . To find the  $y$  value, we plug this value for  $x$  back into either equation, which gives  $y = 1$ . So, the point that the two lines intersect is  $(-1,1)$ . *Note: this point can also be found by graphing.*

47. At the point where the two lines intersect, they will have the same  $y$  value, so we can set  $f(x)$  and  $g(x)$  equal to each other. So,  $-\frac{4}{5}x + \frac{274}{25} = \frac{9}{4}x + \frac{73}{10}$ . Solving for  $x$  gives  $x = 1.2$ . To find the  $y$  value, we plug this value for  $x$  back into either equation, which gives  $y = 10$ . So, the point that the two lines intersect is  $(-1.2,10)$ .

49. Plan A can be modeled by the linear equation  $A(m) = 30 + .18m$ , and Plan B can be represented by the fixed equation  $B(m) = 50$ . As the graph shows, the cost of renting a car is cheaper with Plan A, until a certain point. This is the point of intersection, which can be found algebraically or graphically. This point is  $(111.11, 50)$  meaning that at around 111 miles, it is cheaper to go with Plan B.

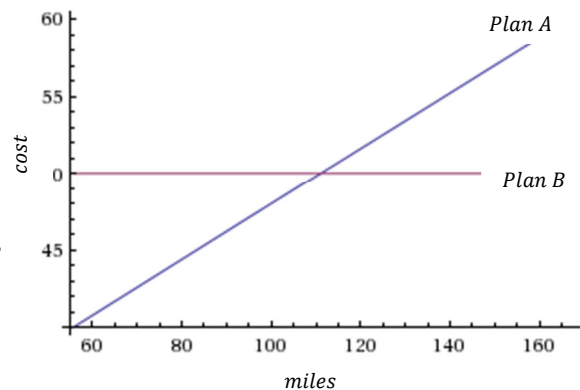

51. (a)

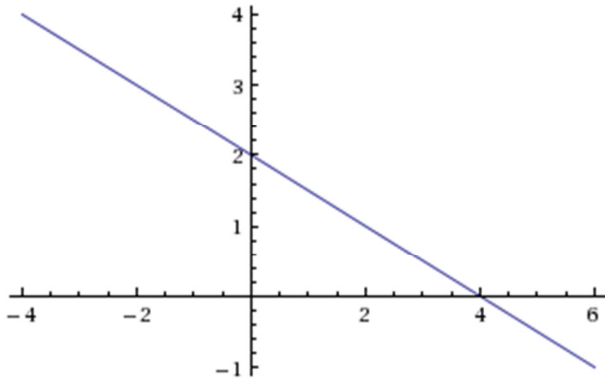

To find the point of intersection algebraically, we set the two lines equal to each other and solve for  $x$ . So,  $2 - \frac{1}{2}x = 1 + cx$ . This gives us  $x = \frac{1}{c} + 2$ . Plugging this back into either equation gives the  $y$  value  $y = 2 + 2c$ . So the point of intersection is  $(\frac{1}{c} + 2, 2 + 2c)$

(b) The  $x$ -coordinate has the form  $x = \frac{1}{c} + 2$ , so we use  $x = 10$  to solve for  $c$ . So,  $10 = \frac{1}{c} + 2$ . This gives us  $c = \frac{1}{8}$ .

(c) For the point to lie on the  $x$ -axis,  $y = 0$ . The  $y$ -coordinate has the form  $2+2c$ , so we use  $y = 0$  to solve for  $c$ . So,  $0 = 2 + 2c$ . This gives us  $c = -1$ .

### 2.3 Solutions to Exercises

1. (a) 696 (b) 4 years  
(c)  $696/4 = 174$  students/year (d)  $1001 - 4(174) = 305$   
(e)  $P(t) = 174t + 305$  (f)  $P(11) = 174(11) + 305 = 2219$  people

3. (a) From this information we can make two ordered pairs (410, 71.50) and (720, 118). The slope between these two points is  $\frac{118-71.50}{720-410} = 0.15$ . So, the equation of the line has the form  $f(x) = 0.15x + b$ . To find  $b$ , we can substitute either of the two points in for  $x$  and  $f(x)$  and solve for  $b$ . For this equation,  $b = 10$ . So, the final equation is  $f(x) = 0.15x + 10$ .

(b) The slope (0.15) is the price per minute of 15 cents, and the  $y$ -intercept (10) is

the flat monthly fee of ten dollars.

(c)  $f(687) = 0.15(687) + 10 = 113.05$ .

5. (a) From this information we can make two ordered pairs (1991, 4360) and (1999, 5880). The slope between these two points is  $\frac{5880-4360}{1999-1991} = 190$ . The slope represents population growth of moose per year. If we want the equation to represent population growth in years after 1990, we have to figure out the moose population in 1990, which will be the y-intercept. We can subtract 190 from the population in 1991 to get the population in 1990, So  $b = 4170$ . So, the final equation is  $f(t) = 190t + 4170$ .

(b) 2003 is 13 years after 1990, so we will evaluate  $f(13) = 6640$ .

7. (a) From this information we have an ordered pair (16, 2010) and the slope of  $-2.1$ . The slope is negative because the helium is being depleted. The slope represents the amount of helium being depleted each year. We want the equation to represent helium reserves in terms of the number of years since 2010, so the y-intercept will be helium amount in 2010, which is given to be 16. So, the final equation is  $R(t) = -2.1t + 16$ .

(b) 2015 is 5 years after 2010, so we will evaluate  $R(5) = 5.5$ .

(c) We want to know the value of  $t$  when  $R(t) = 0$ . So, we replace  $R(t)$  with 0 and solve for  $t$ .  $0 = -2.1t + 16$ , so  $t = 7.6$  years.

9. The two cell phone plans can be modeled by two linear equations: the first plan by  $y = 0.26x$ , the second plan by  $y = 19.95 + 0.11x$ . When the two equations are equal to each other, the cost for that amount of minutes will be the same for both plans. To find that point, we can set the equations equal to each other and solve for  $x$ . So,  $0.26x = 19.95 + 0.11x$ . This gives us  $x = 133$ . So, if you use less than 133 minutes, the first plan is cheaper, if you use more than 133 minutes, the second plan is cheaper.

11. The two pay options can be modeled by two linear equations: the first by  $f(s) = 17,000 + 0.12s$ , the second by  $g(s) = 20,000 + 0.05s$ . When the two equations are equal to each other, the income for that amount of sales will be the same for both options.

To find that point, we can set the equations equal to each other and solve for  $x$ . So,  $17,000 + 0.12s = 20,000 + 0.05s$ . This gives us  $s = 42,857$ . So, if you sell less than \$42,857 of jewelry, option A produces a larger income, if you sell more than \$42,857 of jewelry, option B produces a larger income.

13. It is useful to draw a picture for this problem (see below). The area of a triangle is found by  $A = \frac{1}{2}bh$ . We know that the

base( $b$ ) = 9, but we don't know the height( $h$ ).

We do know, however, that the height of the triangle will be the  $x$  value at the point where the two lines intersect. The equation for the

line perpendicular to  $f(x)$  is  $g(x) = \frac{7}{6}x$ ,

because its slope will be the opposite reciprocal and it has a  $y$ -intercept at  $(0,0)$ . To find the

point where the two lines intersect, we can set them equal to each other and solve for  $x$ . This gives us  $x = 4.44$ , which is the height of the triangle. So, the Area =

$$\frac{1}{2}(9)(4.44) = 19.98.$$

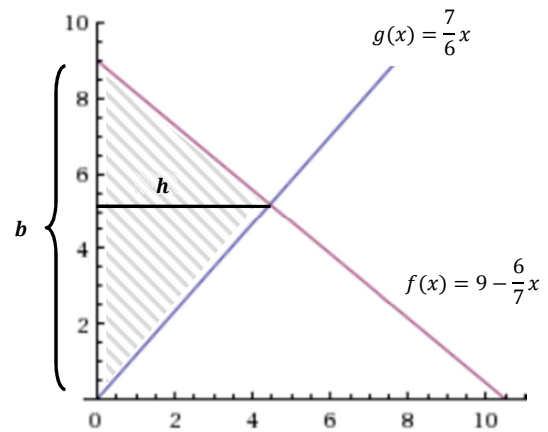

15. The equation of the line parallel to  $f(x)=1+2x$  which passes through  $(2, 7)$  has equation  $y-y_1=m(x-x_1)$  with  $m=2$ ,  $x_1=2$ , and  $y_1=7$ :  
 $y-7=2(x-2) \Rightarrow y=g(x)=2x+3$ .

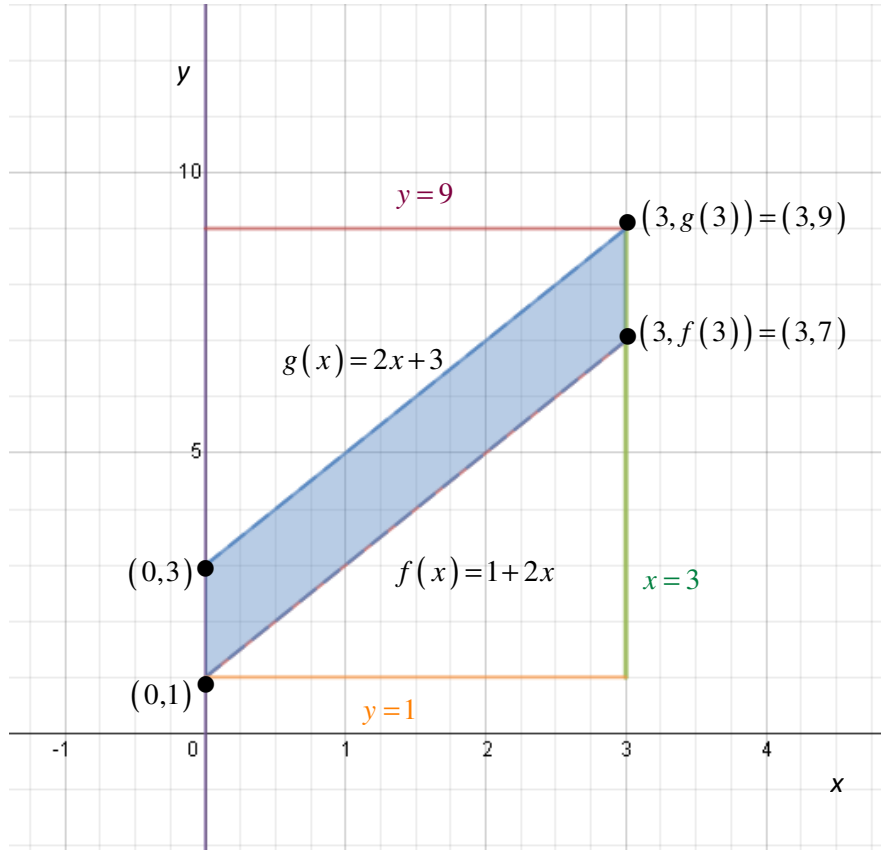

The area of the rectangle drawn around the parallelogram is  $(9-1)\times(3-0)=24$  square units.

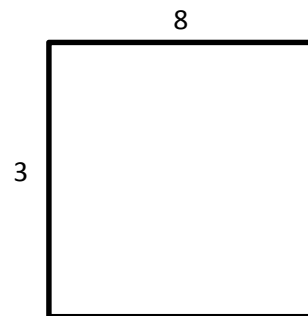

The area of the upper triangle is

$$\frac{1}{2}(9-3)(3-0)=\frac{1}{2}\times 6\times 3=9 \text{ square units.}$$

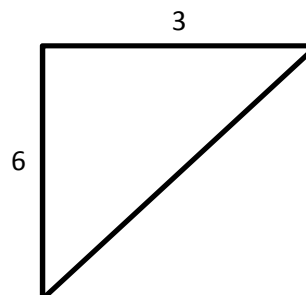

The area of the lower triangle is

$$\frac{1}{2}(7-1)(3-0) = \frac{1}{2} \times 6 \times 3 = 9 \text{ square units.}$$

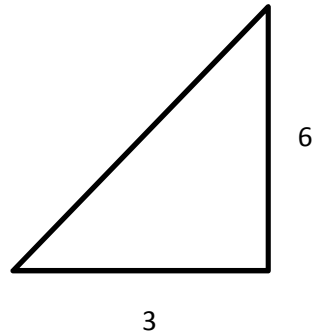

Therefore, the area of the region shaded in blue in the original figure -- the area of the parallelogram bounded by the  $y$ -axis, the line  $x=3$ , the line  $f(x)=1+2x$ , and the line parallel to  $f(x)$  passing through  $(2, 7)$  which has equation  $g(x)=2x+3$  -- is the area of the rectangle minus the area of the two triangles. So, the area of the parallelogram is  $24-9-9=6$  square units.

**Answer: 6**

Note: there are other ways to solve this problem, such as using the formula for the area of a rectangle:  $A = bh$ . Imagining turning the parallelogram so that the segment along the  $y$ -axis is the base. The solution would start the same way as the solution above to show that  $b = 2$ . Looking at the figure this way, the height to the top is 3, so we see that we get the same answer as above:  $A = bh = 2 \cdot 3 = 6$ .

17. The area of the triangle is  $A = \frac{1}{2}bh$ . From the figure on the right we can see that the height is  $b$ , and the value of the  $x$ -intercept of the line  $f(x)$ . The  $x$ -intercept is found by replacing  $f(x)$  with 0 and solving for  $x$ . This gives  $x = -\frac{b}{m}$ . So, the area in terms of  $m$  and  $b$  is  $A = \left(\frac{1}{2}\right)\left(-\frac{b}{m}\right)(b)$  which can be simplified to  $A = -\frac{b^2}{2m}$ .

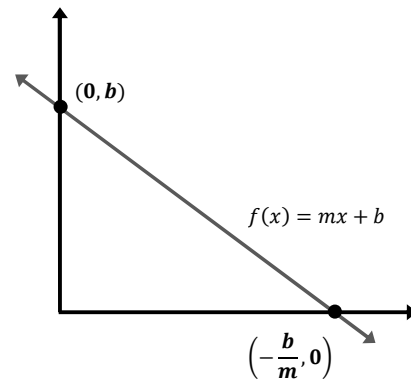

19. (a) Mississippi home values increased at a rate of  $\frac{71,400-25,200}{2000-1950} = 924$  dollars/year, and the Hawaii home values increased at a rate of  $\frac{272,700-74,400}{2000-1950} = 3,966$  dollars/year. So, Hawaii's home values increased faster.

(b) 80,640

(c) We can model these two equations in the following way:  $M(x) = 71,400 + 924x$  and

$H(x) = 272,700 + 3,966x$ , where  $x$  is the number of years after 2000. To find when house values are the same in both states, we can set the equations equal to each other and solve for  $x$ . This gives  $x = -66.17$ , which would mean 66 years before 2000, so 1934.

21. We can think of these points on the coordinate plane as shown in the figure to the right. Pam will be closest to Paris when there is the shortest distance between her and Paris, which is when the dotted line is perpendicular to her path. We can find the equations of both lines, if we make her starting place  $R(0,0)$  and her

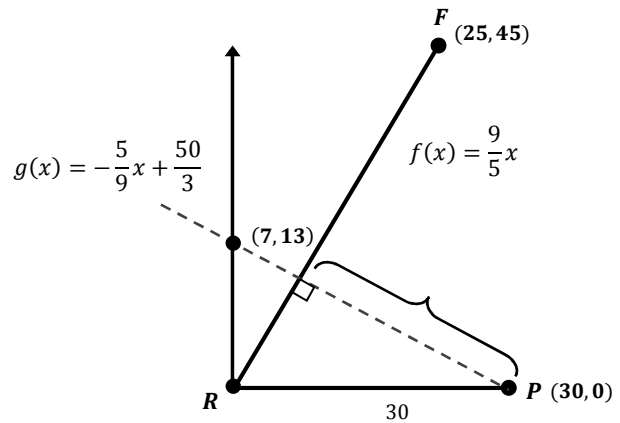

ending place  $F(25,45)$ . The equation for her path is  $f(x) = \frac{9}{5}x$ , and the equation for the dotted line is perpendicular to her path, so it has a slope of  $-\frac{5}{9}$ , and we know the point  $(30,0)$  lies on this line, so we can find the y-intercept to be  $(0, \frac{50}{3})$ . The equation for the dotted line is  $g(x) = -\frac{5}{9}x + \frac{50}{3}$ . Knowing these equations helps us to find the point where they intersect, by setting them equal to each other and solving for  $x$ . This point is  $(7.09, 12.76)$ , which on the graph is rounded to  $(7,13)$ . So, when she is at this point she is

closest to Paris, and we can calculate this distance using the distance formula with points (7,13) and (30,0), which comes out to approximately 26.4 miles.

## 2.4 Solutions to Exercises

1.

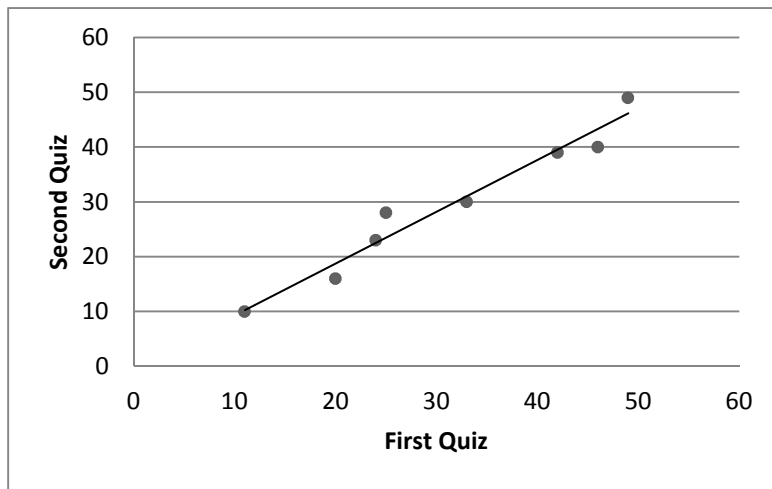

3.

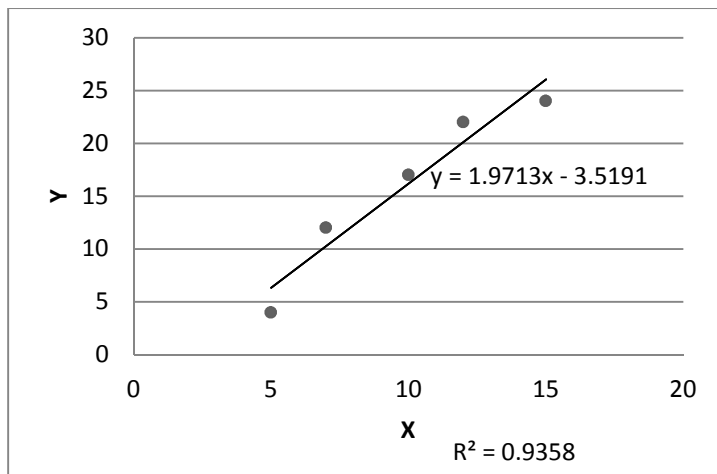

Regression line equation:  $f(x) = 1.971x - 3.519$ .

Correlation coefficient:  $R=0.966954$ .



5.

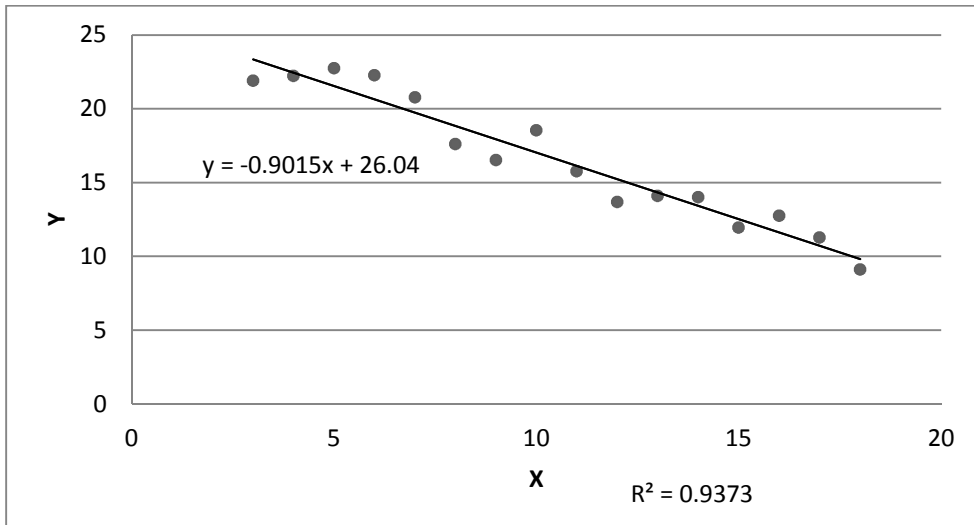

Regression line equation:  $f(x) = -0.901x + 26.04$ .

Correlation coefficient,  $R = -0.967988$

7. With the equation of a line  $y = ax + b$  we are given  $a = -1.341$  and  $b = 32.234$ , let our regression line be,  $y = -1.341x + 32.234$ . Since our correlation coefficient is close to negative one ( $r = -0.896$ ) we know that the regression line will be a relatively good fit for the data and thus will give us a good prediction. Since  $x$  is the number of hours someone watches TV and  $y$  is the amount of sit-ups someone can do we can plug in 11 for  $x$  in our equation to get the predicted amount of sit-ups that person can do. That is,

$$y = -1.341(11) + 32.234 = \frac{17483}{1000} \approx 17.483.$$

A person who watches 11 hours of TV a day can do a predicted 17.5 sit-ups.

9. Noticing that  $r$  is positive and close to one, we look for a scatter plot that is increasing and that has plotted points that are close to the line of regression. D.  $r = 0.95$

11. Noticing that  $r$  is positive but that  $r$  is not close to one, we look for a scatter plot that is increasing and has points that are further away from the regression line. A.  $r = 0.26$

13.

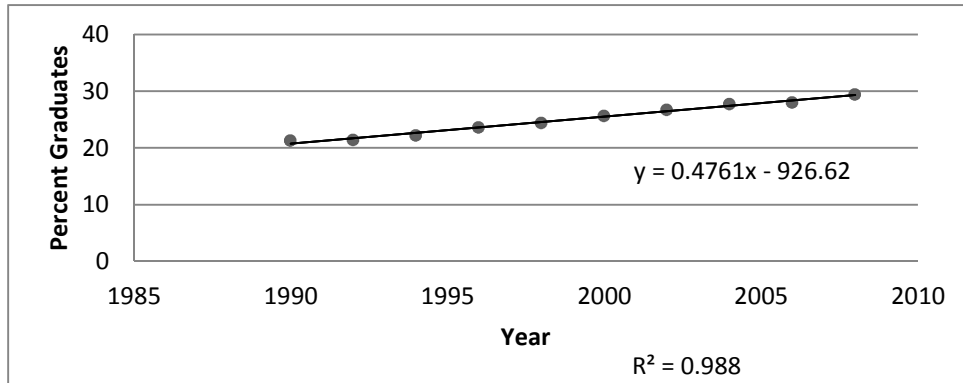

From graphing the data it is apparent that the trend appears linear. Finding the equation for the regression line with a computer we can calculate what year (if the trend continues) the percentage will exceed 35%. That is  $y = 0.476x - 926.6$ , with  $x$  equal to the year and  $y$  equal to percentage of persons 25 years or older who are college graduates. We can plug in  $y = 35$ , so  $35 = 0.476x - 926.6$ ; adding 926.6 to each side,  $961.6 = 0.476x$ . Then by dividing both sides by 0.476 we arrive at  $x = 2020.17 \approx 2020$ . And so we can conclude that if the trend continues we will arrive at 35% of college graduates being persons over 25 years of age in the year 2020.

## 2.5 Solutions to Exercises

1.  $f(x) = \frac{1}{2}|x + 2| + 1$

3.  $f(x) = -3.5|x - 3| + 3$

5.

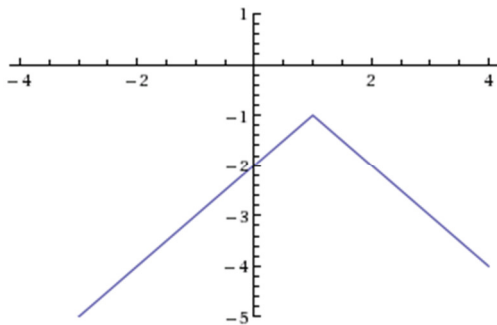

7.

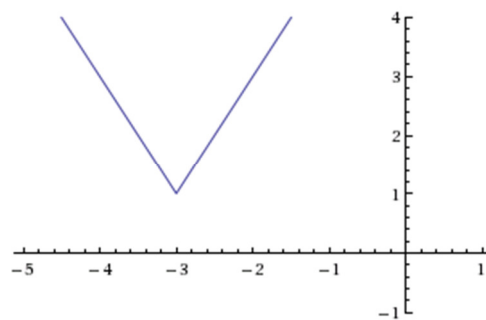

9.

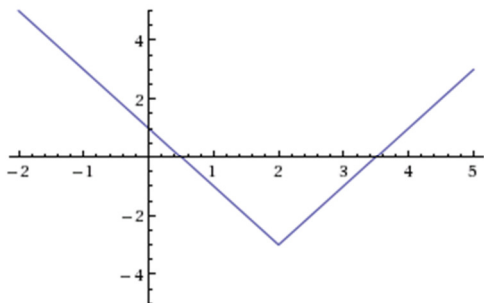

11. The only two numbers whose absolute value is 11 are -11 and 11, so:

$$5x - 2 = 11 \quad \text{or} \quad 5x - 2 = -11$$

$$5x = 13 \quad \text{or} \quad 5x = -9$$

$$x = \frac{13}{5} \quad \text{or} \quad x = -\frac{9}{5}$$

13.  $2|4 - x| = 7$

$$|4 - x| = \frac{7}{2}$$

$$4 - x = \frac{7}{2} \quad \text{or} \quad 4 - x = -\frac{7}{2}$$

$$-x = -\frac{1}{2} \quad \text{or} \quad -x = -\frac{15}{2}$$

$$x = \frac{1}{2} \quad \text{or} \quad x = \frac{15}{2}$$

15.  $3|x + 1| - 4 = -2$

$$|x + 1| = \frac{2}{3}$$

$$x + 1 = \frac{2}{3} \quad \text{or} \quad x + 1 = -\frac{2}{3}$$

$$x = -\frac{1}{3} \quad \text{or} \quad x = -\frac{5}{3}$$

17. Horizontal intercepts occur when  $f(x) = 0$ , giving the equation:

$$2|x + 1| - 10 = 0$$

Then:  $|x + 1| = 5$

$$x + 1 = 5 \quad \text{or} \quad x + 1 = -5$$

$$x = 4 \quad \text{or} \quad x = -6 \quad \text{so the horizontal intercepts are } (4, 0) \text{ and } (-6, 0).$$

Vertical intercepts occur when  $x = 0$ :  $f(0) = 2|0 + 1| - 10 = 2(1) - 10 = -8$ . So the vertical intercept is  $(0, -8)$ .

19. Horizontal intercepts occur when  $f(x) = 0$ , giving the equation:

$$-3|x - 2| - 1 = 0$$

Then:  $|x - 2| = -\frac{1}{3}$ . The absolute value of a quantity cannot give a negative value, so this equation has no solutions; there are no horizontal intercepts.

Vertical intercepts occur when  $x = 0$ :  $f(0) = -3|0 - 2| - 1 = -3(2) - 1 = -7$ . So the vertical intercept is  $(0, -7)$ .

21. First, we solve the equation  $|x + 5| = 6$ :

$$x + 5 = 6 \quad \text{or} \quad x + 5 = -6$$

$$x = 1 \quad \text{or} \quad x = -11$$

From here, either use test points in the regions  $x < -11$ ,  $-11 < x < 1$ , and  $x > 1$  to determine which of these regions are solutions, or consider the graph of  $f(x) = |x + 5|$ . Using the prior method, let's test the points with  $x$ -coordinates  $-12$ ,  $0$ , and  $2$  (though you could use different numbers, as long as there's one from each of the three regions above):

$|-12 + 5| = |-7| = 7$ , which is greater than  $6$ , and thus not a solution to the original inequality  $|x + 5| < 6$ .

$$|0 + 5| = |5| = 5, \text{ which is less than } 6, \text{ and thus a solution to } |x + 5| < 6.$$

$$|2 + 5| = |7| = 7, \text{ which is greater than } 6, \text{ and thus not a solution to } |x + 5| < 6.$$

Since  $0$  is the only one that gave a solution to the inequality, the region it represents,  $-11 < x < 1$ , is the solution set.

23. First, we solve the equation  $|x - 2| = 3$ :

$$x - 2 = 3 \quad \text{or} \quad x - 2 = -3$$

$$x = 5 \quad \text{or} \quad x = -1$$

From here, either use test points in the regions  $x < -1$ ,  $-1 < x < 5$ , and  $x > 5$  to determine which of these regions are solutions, or consider the graph of  $f(x) = |x - 2|$ . Using the prior method, let's test the points with  $x$ -coordinates  $-2$ ,  $0$ , and  $6$ :

$$|-2 - 2| = |-4| = 4, \text{ which is greater than } 3, \text{ and thus a solution to } |x - 2| \geq 3.$$

$$|0 - 2| = |-2| = 2, \text{ which is less than } 3, \text{ and thus not a solution to } |x - 2| \geq 3.$$

$$|6 - 2| = |4| = 4, \text{ which is greater than } 3, \text{ and thus a solution to } |x - 2| \geq 3.$$

Since  $-2$  and  $6$  gave solutions to the inequality, the regions it represents give us the full solution set:  $x \leq -1$  or  $x \geq 5$ .

25. First, we solve the equation  $|3x + 9| = 4$ :

$$3x + 9 = 4 \quad \text{or} \quad 3x + 9 = -4$$

$$x = -\frac{5}{3} \quad \text{or} \quad x = -\frac{13}{3}$$

From here, either use test points in the regions  $x < -\frac{13}{3}$ ,  $-\frac{13}{3} < x < -\frac{5}{3}$ , and  $x > -\frac{5}{3}$  to determine which of these regions are solutions, or consider the graph of  $f(x) = |3x + 9|$ . Using the prior method, let's test the points with  $x$ -coordinates  $-5$ ,  $-2$ , and  $0$ :

$$|3(-5) + 9| = |-6| = 6, \text{ which is greater than } 4, \text{ and thus not a solution to } |3x + 9| < 4.$$

$$|3(-2) + 9| = |3| = 3, \text{ which is less than } 4, \text{ and thus a solution to } |3x + 9| < 4.$$

$$|3(0) + 9| = |9| = 9, \text{ which is greater than } 4, \text{ and thus not a solution to } |3x + 9| < 4.$$

Since  $-2$  is the only one that gave a solution to the inequality, the region it represents,  $-\frac{13}{3} < x < -\frac{5}{3}$ , is the solution set.

### 3.1 Solutions to Exercises

1. (a)  $f(x)$  will approach  $+\infty$  as  $x$  approaches  $\infty$ .  
(b)  $f(x)$  will still approach  $+\infty$  as  $x$  approaches  $-\infty$ , because any negative integer  $x$  will become positive if it is raised to an even exponent, in this case,  $x^4$ .
3. (a)  $f(x)$  will approach  $+\infty$  as  $x$  approaches  $\infty$ .  
(b)  $f(x)$  will approach  $-\infty$  as  $x$  approaches  $-\infty$ , because  $x$  is raised to an odd power, in this case,  $x^3$ .
5. (a)  $f(x)$  will approach  $-\infty$  as  $x$  approaches  $\infty$ , because every number is multiplied by  $-1$ .  
(b)  $f(x)$  will approach  $-\infty$  as  $x$  approaches  $-\infty$ , since any negative number raised to an even power (in this case 2) is positive, but when it's multiplied by  $-1$ , it becomes negative.
7. (a)  $f(x)$  will approach  $-\infty$  as  $x$  approaches  $\infty$ , because any positive number raised to any power will remain positive, but when it's multiplied by  $-1$ , it becomes negative.  
(b)  $f(x)$  will approach  $\infty$  as  $x$  approaches  $-\infty$ , because any negative number raised to an odd power will remain negative, but when it's multiplied by  $-1$ , it becomes positive.
9. (a) The degree is 7.  
(b) The leading coefficient is 4.
11. (a) The degree is 2.  
(b) The leading coefficient is -1.
13. (a) The degree is 4.  
(b) The leading coefficient is -2.
15. (a)  $(2x + 3)(x - 4)(3x + 1) = (2x^2 - 5x - 12)(3x + 1) = 6x^3 - 13x^2 - 41x - 12$   
(b) The leading coefficient is 6.  
(c) The degree is 3.
17. (a) The leading coefficient is negative, so as  $x \rightarrow +\infty$  the function will approach  $-\infty$ .  
(b) The leading coefficient is negative, and the polynomial has even degree so as  $x \rightarrow -\infty$  the function will approach  $-\infty$ .
19. (a) The leading coefficient is positive, so as  $x \rightarrow +\infty$ , the function will approach  $+\infty$ .  
(b) The leading coefficient is positive, and the polynomial has even degree so as  $x \rightarrow -\infty$ , the function will approach  $+\infty$ .
21. (a) Every polynomial of degree  $n$  has a maximum of  $n$   $x$ -intercepts. In this case  $n = 5$  so we get a maximum of five  $x$ -intercepts.  
(b) The number of turning points of a polynomial of degree  $n$  is  $n - 1$ . In this case  $n = 5$  so we get four turning points.

23. Knowing that an  $n^{\text{th}}$  degree polynomial can have a maximum of  $n - 1$  turning points we get that this function with two turning points could have a minimum possible degree of three.

25. Knowing that an  $n^{\text{th}}$  degree polynomial can have a maximum of  $n - 1$  turning points we get that this function with four turning points could have a minimum possible degree of five.

27. Knowing that an  $n^{\text{th}}$  degree polynomial can have a maximum of  $n - 1$  turning points we get that this function with two turning points could have a minimum possible degree of three.

29. Knowing that an  $n^{\text{th}}$  degree polynomial can have a maximum of  $n - 1$  turning points we get that this function with four turning points could have a minimum possible degree of five.

31. (a) To get our vertical intercept of our function we plug in zero for  $t$  we get  $f(0) = 2((0) - 1)((0) + 2)((0) - 3) = 12$ . Therefore our vertical intercept is  $(0,12)$

(b) To get our horizontal intercepts when our function is a series of products we look for when we can any of the products equal to zero. For  $f(t)$  we get  $t = -2, 1, 3$ . Therefore our horizontal intercepts are  $(-2,0)$ ,  $(1,0)$  and  $(3,0)$ .

33. (a) To get our vertical intercept of our function we plug in zero for  $n$  we get  $g(0) = -2((3(0) - 1)(2(0) + 1)) = 2$ . Therefore our vertical intercept is  $(0,2)$

(b) To get our horizontal intercepts when our function is a series of products we look for when we can any of the products equal to zero. For  $g(n)$  we get  $n = \frac{1}{3}, \frac{-1}{2}$ . Therefore our horizontal intercepts are  $(\frac{1}{3}, 0)$  and  $(\frac{-1}{2}, 0)$ .

### 3.2 Solutions to Exercises

1.  $f(x) = x^2 - 4x + 1$

3.  $f(x) = -2x^2 + 8x - 1$

5.  $f(x) = \frac{1}{2}x^2 - 3x + \frac{7}{2}$

7. Vertex:  $(-\frac{10}{4}, -\frac{1}{2})$  x-intercepts:  $(-3,0)(-2,0)$  y-intercept:  $(0,12)$

9. Vertex:  $(\frac{10}{4}, -\frac{29}{2})$  x-intercepts:  $(5,0)(-1,0)$  y-intercept:  $(0,4)$

11. Vertex:  $(\frac{3}{4}, 1.25)$  x-intercepts:  $\pm\sqrt{5}$  y-intercept:  $(0, -1)$

13.  $f(x) = (x - 6)^2 - 4$

15.  $h(x) = 2(x + 2)^2 - 18$

17. We have a known  $a$ ,  $h$ , and  $k$ . We are trying to find  $b$  and  $c$ , to put the equation into quadratic form. Since we have the vertex,  $(2, -7)$  and  $a = -8$ , we can put the equation into vertex form,  $f(x) = -8(x - 2)^2 - 7$  and then change that into quadratic form. To do this, we start by foiling  $(x - 2)^2$  and algebraically continuing until we have the form  $f(x) = ax^2 + bx + c$ . We get  $f(x) = -8x^2 + 32x - 39$ , so  $b = 32$  and  $c = -39$ .

$$19. f(x) = -\frac{2}{3}x^2 - \frac{4}{3}x + 2$$

$$21. f(x) = \frac{3}{5}x^2 - \frac{21}{5x} + 6$$

23.  $-\frac{b}{2a}$  is the x-coordinate of the vertex, and we are given the x-coordinate of the vertex to be 4, we can set  $-\frac{b}{2a}$  equal to 4, and solve for  $b$ , which gives  $b = -8a$ . The  $b$  in the vertex formula is the same as the  $b$  in the general form of a quadratic equation  $y = ax^2 + bx + c$ , so we can substitute  $-8a$  for  $b$  and  $-4$  for  $c$  (the y-intercept) into the quadratic equation:  $y = ax^2 - 8ax - 4$ . Plugging in the x and y coordinates from the y intercept gives  $0 = 16a - 32a - 4$ , and solving for  $a$  gives  $a = \frac{-1}{4}$ . After plugging  $a$  back in we get  $y = -\frac{1}{4}x^2 - 8\left(-\frac{1}{4}\right)x - 4$  which simplifies to  $y = -\frac{1}{4}x^2 + 2x - 4$ .

25.  $-\frac{b}{2a}$  is the x-coordinate of the vertex, and we are given the x-coordinate of the vertex to be -3, we can set  $-\frac{b}{2a}$  equal to -3, and solve for  $b$ , which gives  $b = 6a$ . So our equation is  $y = ax^2 + 6ax + c$ . Plugging in the vertex coordinates for  $x$  and  $y$  allow us to solve for  $c$ , which gives  $c = 2 + 9a$ . Plugging  $c$  back into  $y$  gives  $y = ax^2 + 6ax + 2 + 9a$ . To solve for  $a$  we plug in values from the other point,  $-2 = 9a + 18a + 2 + 9a$  which gives  $a = -\frac{1}{9}$ . We have  $b$  and  $c$  in terms of  $a$ , so we can find them easily now that we know the value of  $a$ . So, the final equation is  $y = -\frac{1}{9}x^2 - \frac{2}{3}x + 1$ .

27. For this problem, part (a) asks for the height when  $t = 0$ , so solving for  $h(0)$  will give us our launching height. In part (b), we are trying to find the peak of the trajectory, which is the same as the vertex, so solving for  $k$  will give us the maximum height. In part (c), we are asked to solve



for  $t$  when  $h(t) = 0$ . We can do this by using the quadratic formula to solve for  $t$ .

- (a) 234 m
- (b) 2909.56 m
- (c) 47.735 sec

29. See the explanation for problem 27 for hints on how to do this problem.

- (a) 3 ft
- (b) 111 ft
- (c) 72.48 ft

31. The volume of the box can be expressed as  $V = 6 * x * x$  or  $V = 6x^2$ . So if we want the volume to be 1000, we end up with the expression  $6x^2 - 1000 = 0$ . Solving this

equation for  $x$  using the quadratic formula we get  $= \pm 10\sqrt{\frac{5}{3}}$ .

Because we cannot have negative length, we are left with

$x = 10\sqrt{\frac{5}{3}} \approx 12.90$ . So the length of the side of our box is  $12 + 12.90 = 24.90$ . So, our piece of cardboard is  $24.90 * 24.90 = 620$ .

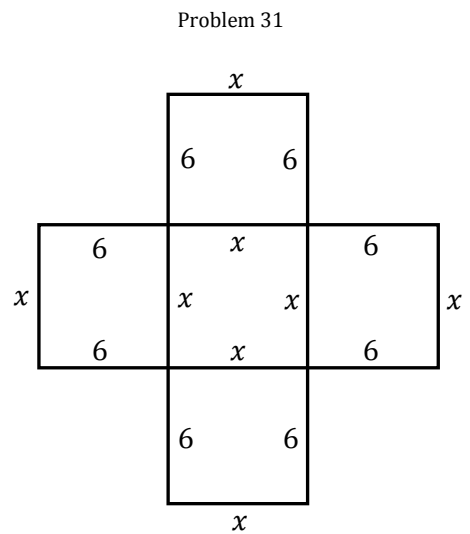

33. Picking  $x$  to be our vertical side, we are left with  $500 - 3x$  for the remaining two sides. Because there are two of them, we divide that by two, so that each side is  $\frac{500-3x}{2} = 250 - \frac{3x}{2}$ . So, the area can be expressed as  $= 250x - \frac{3}{2}x^2$ . When this function has a maximum, the area of the enclosure will be maximized. This a concave down parabola and thus has a maximum point at its vertex. The  $x$ -coordinate of the vertex is  $-\frac{b}{2a}$ , which we can calculate to be  $x = \frac{-250}{-2(\frac{3}{2})} = 83\frac{1}{3}$ . This is the

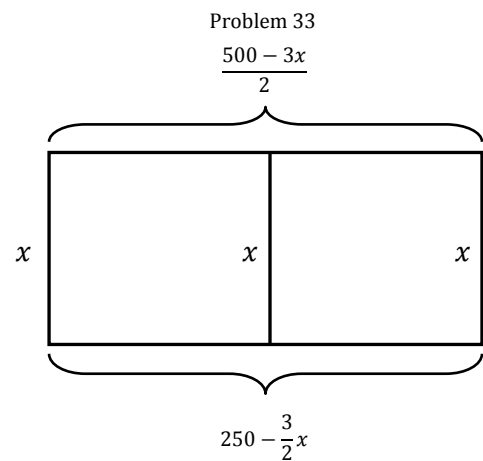

dimension of the enclosure  $x$ . To find the long dimension, we can plug this value for  $x$  into our

expression  $250 - \frac{3}{2}x$  which = 125. So, the dimensions are  $83\frac{1}{3}$  ft for three vertical sides and 125 ft for the two long sides.

35. Picking  $x$  to be the length of the circumference of our circle we get that the amount of wire left for the square is  $56 - x$ . So, each side of the square has length  $\frac{56-x}{4}$ . Our areas will be

$\left(\frac{56-x}{4}\right)^2$  and  $\frac{x^2}{2\pi}$ . We get  $\frac{x^2}{4\pi}$  because our radius is  $x = 2\pi r \rightarrow r = \frac{x}{2\pi} \rightarrow A_{\text{cir}} = \frac{x^2}{4\pi}$ . Adding these together we get  $A_{\text{tot.}} = \frac{x^2}{16} - 7x + 196 + \frac{x^2}{4\pi} = \left(\frac{1}{16} + \frac{1}{4\pi}\right)x^2 - 7x + 196$ . This equation forms a concave up parabola and therefore has a minimum point at its vertex located at  $x = \frac{7}{\left(\frac{1}{16} + \frac{1}{4\pi}\right)} =$

$\frac{112\pi}{\pi+64} \approx 5.24$ . Since we chose  $x$  as our circumference, we are done.

37. To write average attendance as a linear function of price  $A(\$)$  we will need a slope and an  $A$  intercept. We can get slope by using  $\frac{A_2-A_1}{\$_2-\$_1}$ , plugging in our data points (9,31000) and

(11,26000) we get  $\frac{26000-31000}{11-9} = -2500$ . Solving for our  $A$  intercept we get  $A(\$) = -2500 \cdot \$ + b$  then plugging in one of our data points and solving for  $b$  we get  $b = 53500$ . Therefore our linear equation for attendance is  $A(\$) = -2500(\$) + 48500$ . We can then write an equation for revenue as price  $\times$  attendance or  $\$ \cdot A(\$)$  or  $Rev(\$) = -2500 \cdot \$^2 + 48500 \cdot \$$ . This is an equation of a parabola in standard form. Having a negative ( $a$ ) value we know that this parabola is concave down with a maximum  $Rev(\$)$  value its vertex. The  $\$$  value of the vertex of a parabola is  $\frac{-b}{2a}$ , therefore our vertex is located at  $\frac{-48500}{-2 \cdot 2500}$ . So our revenue maximizing price will be \$10.70.

39. (a) To get the equation of the mountain side, we know that for every twenty feet in the  $x$  direction we get a rise of two feet. Then our rise over run (slope) will be  $\frac{2ft}{20ft} = \frac{1}{10}$ . Because our

graph of the mountain side starts at (0,0) we know our vertical intercept is zero. Then to get the equation for the height of the balloon  $f(x)$  above the mountain side  $mt(x)$  we get  $f(x) -$

$mt(x) = \frac{-1}{1250}x^2 + 45x - \frac{1}{10}x = \frac{-1}{1250}x^2 + \frac{449}{10}x$ .  $f(x) - mt(x)$  is a concave down parabola and

therefore has a maximum value at its vertex at  $x = \frac{-b}{2a} = \frac{-449}{10\left(\frac{-2}{1250}\right)} = 28062.5$ . Then plugging this

value into  $f(x) - mt(x)$  we get  $f(28062.5) - mt(28062.5) = \frac{-1}{1250}(28062.5)^2 + \frac{449}{10}(28062.5) = 632809.375$  ft.

(b) Given  $f(x) = \frac{-1}{1250}x^2 + 45x$  is the balloon's height above ground level then there is a maximum point at the vertex of the parabola with an  $x = \frac{-b}{2a} = -\frac{45}{\frac{-2}{1250}} = 28125$ . Plugging this value back into  $f(x)$  we get 632812.5 feet as our maximum height above ground level.

(c) To find where the balloon lands we solve for the zeros of  $f(x) - mt(x) = \frac{-1}{1250}x^2 + \frac{449}{10}x$ . Then we get  $\frac{-1}{1250}x^2 + \frac{449}{10}x = 0$  therefore  $\frac{-1}{1250}x = \frac{-449}{10}$  therefore  $x = 56125$  feet.

(d) To find when the balloon is 50ft off the ground we set  $f(x) = 50$  and solve for  $x$ . We can write this in the expression  $\frac{-1}{1250}x^2 + \frac{449}{10}x = 50$  or  $\frac{-1}{1250}x^2 + \frac{449}{10}x - 50 = 0$ . Then using the quadratic equation we get  $x = 1.11$  and 56248.9ft. Although it would appear that we have two values for when the balloon is 50 ft high looking at pt (c) we can see that the balloon will have already landed before it reaches 56248.9ft so our only valid result is at 1.11ft.

### 3.3 Solutions to Exercises

1 - 5 To find the C intercept, evaluate  $c(t)$ . To find the t-intercept, solve  $C(t) = 0$ .

1. (a) C intercept at (0, 48)

(b) t intercepts at (4,0), (-1,0), (6,0)

3. (a) C intercept at (0,0)

(b) t intercepts at (2,0), (-1,0), (0,0)

5.  $C(t) = 2t^4 - 8t^3 + 6t^2 = 2t^2(t^2 - 4t + 3) = 2t^2(t - 1)(t - 3)$ .

(a) C intercept at (0,0)

(b) t intercepts at (0,0), (3,0) (-1,0)

7. Zeros:  $x \approx -1.65$ ,  $x \approx 3.64$ ,  $x \approx 5$ .

9. (a) as  $t \rightarrow \infty, h(t) \rightarrow \infty$ .

(b) as  $t \rightarrow -\infty, h(t) \rightarrow -\infty$

For part a of problem 9, we see that as soon as  $t$  becomes greater than 5, the function  $h(t) = 3(t - 5)^3(t - 3)^3(t - 2)$  will increase positively as it approaches infinity, because as soon as  $t$  is greater than 5, the numbers within each parentheses will always be positive. In b, notice as  $t$  approaches  $-\infty$ , any negative number cubed will stay negative. If you multiply first three terms:  $[3 * (t - 5)^3 * (t - 3)^3]$ , as  $t$  approaches  $-\infty$ , it will always create a positive number. When you then multiply that by the final number:  $(t - 2)$ , you will be multiplying a negative:  $(t - 2)$ , by a positive:  $[3 * (t - 5)^3 * (t - 3)^3]$ , which will be a negative number.

11. (a) as  $t \rightarrow \infty, p(t) \rightarrow -\infty$

(b) as  $t \rightarrow -\infty, p(t) \rightarrow -\infty$

For part a of this problem as  $t$  approaches positive infinity, you will always have two parts of the equation  $p(t) = -2t(t - 1)(3 - t)^2$ , that are positive, once  $t$  is greater than 1:  $[(t - 1) * (3 - t)^2]$ , when multiplied together they stay positive. They are then multiplied by a number that will always be negative:  $-2t$ . A negative multiplied by a positive is always negative, so  $p(t)$  approaches  $-\infty$ . For part b of this problem, as  $t$  approaches negative infinity, you will always have two parts of the equation that are always positive:  $[-2t * (3 - t)^2]$ , when multiplied together stay positive. They are then multiplied by a number that will always be negative:  $(t-1)$ . A negative multiplied by a positive is always negative, so  $p(t)$  approaches  $-\infty$ .

13.  $f(x) = (x + 3)^2(x - 2)$

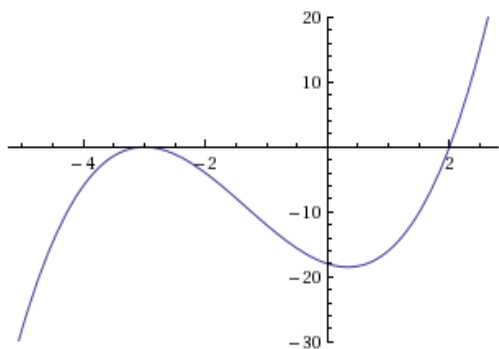

15.  $h(x) = (x - 1)^3(x + 3)^2$

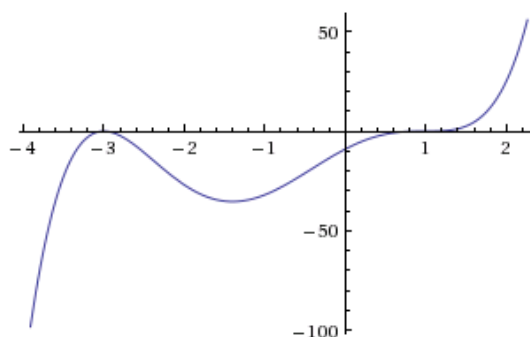

17.  $m(x) = -2x(x - 1)(x + 3)$

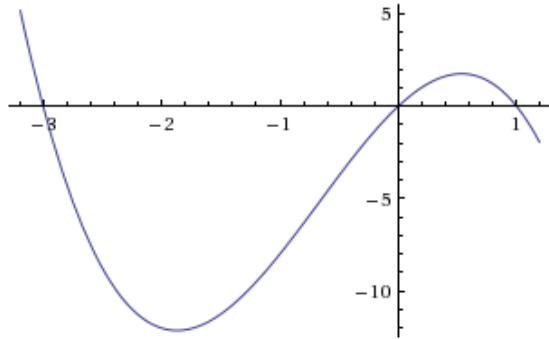

19.  $(x - 3)(x - 2)^2 > 0$  when  $x > 3$

To solve the inequality  $(x - 3)(x - 2)^2 > 0$ , you first want to solve for  $x$ , when the function would be equal to zero. In this case, once you've solved for  $x$ , you know that when  $f(x) = 0$ ,  $x = 3$ , and  $x = 2$ . You want to test numbers greater than, less than, and in-between these points, to see if these intervals are positive or negative. If an interval is positive it is part of your solution, and if it's negative it's not part of your solution. You test the intervals by plugging any number greater than 3, less than 2, or in between 2 and 3 into your inequality. For this problem,  $(x - 3)(x - 2)^2 > 0$  is only positive when  $x$  is greater than 3. So your solution is:  $(x - 3)(x - 2)^2 > 0$ , when  $x > 3$ .

21.  $(x - 1)(x + 2)(x - 3) < 0$  when  $-2 < x < 1$ , and when  $x > 3$

To solve the inequality  $(x - 1)(x + 2)(x - 3) < 0$ , you first want to solve for  $x$ , when the function would be equal to zero. In this case, once you've solved for  $x$ , you know that when  $f(x) = 0$ ,  $x = 1$ ,  $x = -2$ , and  $x = 3$ . You want to test numbers greater than, less than, and in-between these points, to see if these intervals are positive or negative. If an interval is positive it is part of your solution, and if it's negative it's not part of your solution. You test the intervals by plugging any number greater than 3, less than -2, or in between -2 and 1, and in between 1 and 3 into your inequality. For this problem,  $(x - 1)(x + 2)(x - 3) < 0$  is positive when  $x$  is greater than 3, and when it's in between  $-2$  and 1. So your solution is:  $(x - 1)(x + 2)(x - 3) < 0$  when  $-2 < x < 1$ , and when  $x > 3$ .

23. The domain is the values of  $x$  for which the expression under the radical is nonnegative:

$$-42 + 19x - 2x^2 \geq 0$$

$$-(2x^2 - 19x + 42) \geq 0$$

$$-(2x - 7)(x - 6) \geq 0$$

Recall that this graph is a parabola which opens down, so the nonnegative portion is the interval between (and including) the  $x$ -intercepts:  $\frac{7}{2} < x < 6$ .

25. The domain is the values of  $x$  for which the expression under the radical is nonnegative:

$$4 - 5x - x^2 \geq 0$$

$$(x - 4)(x - 1) \geq 0$$

Recall that this graph is a parabola which opens up, so the nonnegative portions are the intervals outside of (and including) the  $x$ -intercepts:  $x \leq 1$  and  $x \geq 4$ .

27. The domain is the values of  $x$  for which the expression under the radical is nonnegative, and since  $(x + 2)^2$  is always nonnegative, we need only consider where  $x - 3 > 0$ , so the domain is  $x \geq 3$ .

29. The domain can be any numbers for which the denominator of  $p(t)$  is nonzero, because you can't have a zero in the denominator of a fraction. So find what values of  $t$  make  $t^2 + 2t - 8 = 0$ , and those values are not in the domain of  $p(t)$ .  $t^2 + 2t - 8 = (t + 4)(t - 2)$ , so the domain is  $\mathbb{R}$  where  $x \neq -4$  and  $x \neq 2$ .

$$31. f(x) = -\frac{2}{3}(x + 2)(x - 1)(x - 3)$$

For problem 31, you can use the  $x$  intercepts you're given to get to the point  $f(x) = a(x + 2)(x - 1)(x - 3)$ , because you know that if you solved for each of the  $x$  values you would end up with the horizontal intercepts given to you in the problem. Since your equation is of degree three, you don't need to raise any of your  $x$  values to a power, because if you foiled  $(x + 2)(x - 1)(x - 3)$  there will be an  $x^3$ , which is degree three. To solve for  $a$ , (your stretch factor, in this case  $-\frac{2}{3}$ ), you can plug the point your given, (in this case it's the  $y$  intercept  $(0, -4)$ ) into your equation:  $-4 = (0 + 2)(0 - 1)(0 - 3)$ , to solve for  $a$ .

$$33. f(x) = \frac{1}{3}(x - 3)^2(x - 1)^2(x + 3)$$

For problem 33, you can use the  $x$  intercepts you're given to get to the point  $f(x) = a(x - 3)^2(x - 1)^2(x + 3)$ , because you know that if you solved for each of the  $x$  values you would end up with the horizontal intercepts given to you in the problem. The problem tells you

at what intercepts has what roots of multiplicity to give a degree of 5, which is why  $(x - 2)$  and  $(x - 1)$  are squared. To solve for  $a$ , (your stretch factor, in this case,  $\frac{1}{3}$ ), you can plug the point your given, (in this case it's the  $y$  intercept  $(0,9)$ ) into your equation:  $9 = (0 - 3)^2(0 - 1)^2(0 + 3)$ , to solve for  $a$ .

$$35. f(x) = -15(x - 1)^2(x - 3)^3$$

For problem 35, you can use the  $x$  intercepts you're given to get to the point  $f(x) = a(x - 1)^2(x - 3)^3$ , because you know that if you solved for each of the  $x$  values you would end up with the horizontal intercepts given to you in the problem. The problem tells you at what intercepts has what roots of multiplicity to give a degree of 5, which is why  $(x - 1)$  is squared, and  $(x - 3)$  is cubed. To solve for  $a$ , (your stretch factor, in this case,  $-15$ ), you can plug the point your given, (in this case it's  $(2,15)$ ) into your equation:  $15 = (2 - 1)^2(2 - 3)^3$ , to solve for  $a$ .

$$37. f(x) = \frac{1}{2}(x + 2)(x - 1)(x - 3)$$

$$39. f(x) = -(x + 1)^2(x - 2)$$

$$41. f(x) = -\frac{1}{9}(x + 3)(x + 2)(x - 1)(x - 3)$$

$$43. f(x) = \frac{1}{24}(x + 4)(x + 2)(x - 3)^2$$

$$45. f(x) = \frac{3}{32}(x + 2)^2(x - 3)^2$$

$$47. f(x) = \frac{1}{6}(x + 3)(x + 2)(x - 1)^3$$

$$49. f(x) = -\frac{1}{16}(x + 3)(x + 1)(x - 2)^2(x - 4)$$

51. See the diagram below. The area of the rectangle is  $A = 2xy$ , and  $y = 5 - x^2$ , so  $A = 2x(5 - x^2) = 10x - 2x^3$ . Using technology, evaluate the maximum of  $10x - 2x^3$ . The  $y$ -value will be maximum area, and the  $x$ -value will be half of base length. Dividing the  $y$ -value by the  $x$ -value gives us the height of the rectangle. The maximum is at  $x = 1.29$ ,  $y = 8.61$ . So, Base = 2.58, Height = 6.67.

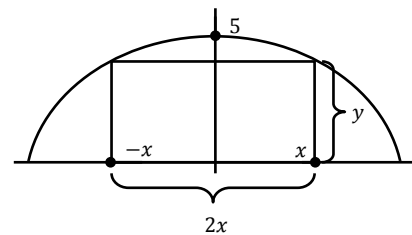

problem 51

## Section 3.4 Solutions

1. b

3. a

5. Vertical asymptote:  $x = -4$ , Horizontal asymptote:  $y = 2$ , Vertical intercept:  $(0, -\frac{3}{4})$ ,

Horizontal intercept:  $(\frac{3}{2}, 0)$ . For problem 5, the vertical asymptote is  $x = -4$  because that gives a 0 in the denominator, which makes the function undefined. The horizontal asymptote is  $y = 2$ , because since the degrees are equal in the numerator, and denominator, the ratio of the leading coefficients the answer. The vertical intercept is  $(0, -\frac{3}{4})$  because  $f(0) = -\frac{3}{4}$ , and the horizontal intercept is  $(\frac{3}{2}, 0)$ , because when the function  $p(x) = 0$ ,  $x = \frac{3}{2}$ .

7. Vertical asymptote:  $x = 2$ , Horizontal asymptote:  $y = 0$ , Vertical intercept:  $(0, 1)$ ,

Horizontal intercept: none. For this problem, the vertical asymptote is  $x = 2$  because  $x = 2$ , gives a 0 in the denominator, which is undefined. The horizontal asymptote is  $y = 0$ , because there is only an  $x$  in the denominator, so as  $x \rightarrow \infty$ ,  $f(x) = 0$ . The vertical intercept is  $(0, 1)$  because  $f(0) = 1$ , and there is no horizontal intercept because when  $f(x) = 0$ , there is no solution for  $x$ .

9. Vertical asymptotes:  $x = -4, \frac{4}{3}$ , Horizontal asymptote:  $y = 1$ , Vertical intercept:

$(0, \frac{5}{16})$ , Horizontal intercepts:  $(-\frac{1}{3}, 0), (5, 0)$ . There are two vertical asymptotes because the denominator is equal to 0 for two different values of  $x$ . The horizontal asymptote is  $y = 1$ , because when the degrees in the numerator and denominator are equal, the ratio of their coefficients is 1. The vertical intercept is  $\frac{5}{16}$ , because  $f(0) = \frac{5}{16}$ , and the horizontal intercepts are  $-\frac{1}{3}, 5$  because when  $f(x) = 0$ ,  $x$  can equal both  $-\frac{1}{3}$ , and 5.

11. Vertical asymptote: there is no vertical asymptote, Horizontal asymptote:  $y = 1$ , Vertical intercept:  $(0, 3)$ , Horizontal intercept:  $(-3, 0)$ . Since  $x = 1$  gives a 0 in both the numerator and the denominator, it does not give a vertical asymptote for problem 11. The horizontal asymptote is  $y = 1$ , because since the degrees are equal in the numerator, and denominator, the leading coefficient is the answer. The vertical intercept is  $(0, 3)$  because  $f(0) = 3$ , and the horizontal intercept is  $(-3, 0)$ , because when the function  $f(x) = 0$ ,  $x = -3$ .



13. Vertical asymptote:  $x = 3$ , Horizontal asymptote: There is no horizontal asymptote, Vertical intercept:  $(0, \frac{1}{4})$ , Horizontal intercepts:  $(-1, 0), (\frac{1}{2}, 0)$ . For problem 13, the vertical asymptote is  $x = 3$  because that gives a 0 in the denominator, which makes the function undefined. Since the degree in the numerator than the degree in the denominator there is no horizontal asymptote, because as  $x \rightarrow \infty, f(x) \rightarrow \infty$ . The vertical intercept is  $(0, \frac{1}{4})$ , because  $f(0) = \frac{1}{4}$ , and the horizontal intercepts are  $(-1, 0), (\frac{1}{2}, 0)$ , because when the function  $f=0, x=-1$  or  $\frac{1}{2}$ .

15. Vertical asymptotes:  $x = 0$ , and  $x = 4$ , Horizontal asymptote:  $y = 0$ , Vertical intercept: none, Horizontal intercepts:  $(-2, 0), (\frac{2}{3}, 0)$ . For problem 15, the vertical asymptotes are at  $x = 0$  and  $x = 4$ , because that is where the denominator becomes zero and the function becomes undefined. The horizontal asymptote is 0 because the highest degree in the denominator is bigger than the highest degree in the numerator. The vertical intercept is undefined because  $f(0) = -4/0$ , which is undefined, and the horizontal intercepts are  $(-2, 0), (\frac{2}{3}, 0)$ , because when  $f(x) = 0, x = -2, 2/3$ .

17. Vertical asymptotes:  $x = -2, 4$ , Horizontal asymptote:  $y = 1$ , Vertical intercept:  $(0, -\frac{15}{16})$ , Horizontal intercepts,  $(1, 0), (-3, 0)$ , and  $(5, 0)$ . The numerator and denominator are already given in factored form, making it easier to find the vertical asymptotes and horizontal intercepts. Computing  $w(0)$  gives the vertical intercept. For the horizontal asymptote, observe that if the numerator and denominator were each multiplied out, they'd both have a leading term of  $x^3$ , so they each have the same degree and the leading coefficient 1, giving the horizontal asymptote  $y = 1$ .

19.  $(x + 1)$  gives us a zero at  $x = -1$ ,  $(x - 2)$  gives us a zero at  $x = 2$ .  $(x - 5)$  and  $(x + 5)$  give us vertical asymptotes at 5 and  $-5$  respectively, because these values give us undefined terms. Using this we then plug  $x = 0$  into our equation which gives us  $-\frac{2}{25}$  however, we need this to equal 4, so multiplying by 50 does the trick.  $y = \frac{50(x-2)(x+1)}{(x-5)(x+5)}$

21. Refer to problem 19. To get 7, we look at the long run behavior of  $y$  as  $x \rightarrow \infty$ . If we expand the numerator and denominator of our function we get that they both have degree 2. Then we get

a horizontal asymptote at 1, so multiplying our function by 7 gives us a horizontal asymptote at

$$7.y = \frac{7(x-4)(x+6)}{(x+4)(x+5)}$$

23. See problem 21 and/or problem 19. To get a double zero at  $x = 2$ , we need the numerator to be able to be broken down into two factors both of which are zero at  $x = 2$ . So,  $(x - 2)^2$  appears in the numerator.

25. . This graph has vertical asymptotes at  $x = -3$  and  $x = 4$ , which gives us our denominator.

The function's only zero is at  $x = 3$ , so we get an  $(x - 3)$  term in our numerator. Evaluating our function so far,  $y = \frac{(x-3)}{(x-4)(x+3)}$ , at zero we get  $\frac{1}{4}$ , but the graph has  $y = 1$  at  $x = 0$ , so multiplying

the function by 4 gives us our desired result,  $y = \frac{4(x-3)}{(x-4)(x+3)}$

27.  $y = -\frac{9(x-2)}{(x-3)(x+3)}$  see problem 25.

29.  $y = \frac{(x-2)(x+3)}{3(x-1)}$  This function has zeros at  $-3$  and  $2$ , so this gives us a numerator of  $(x + 3)(x - 2)$ . We have a vertical asymptote at  $x = 1$  so we get a  $(x - 1)$  term in the denominator. Then evaluating our function so far at zero, we get  $6$ , so including a  $3$  in our denominator gives us our desired result of having  $y(0) = 2$ .

31.  $y = \frac{3(x-1)^2}{(x-2)(x+3)}$  This function has a zero at  $x = 1$  and vertical asymptotes at  $x = 2$  and  $x = -3$ .

However, we need to have an increasing function in the region  $-3 < x < 1$  and  $\frac{(x-1)}{(x-2)(x+3)}$  is decreasing in this region. If we square our numerator we get this outcome without changing any of our zeros or vertical asymptotes. Then we multiply our new function by  $3$  to get our correct  $y$ -intercept.

33.  $y = -\frac{2x(x-3)}{(x-4)(x+3)}$  see problem 31

35.  $y = \frac{(x-1)^3}{(x+1)(x-2)^2}$  Knowing that we have vertical asymptotes at  $x = -1$  and  $x = 2$ , we get that we need an  $(x + 1)$  factor and a  $(x - 2)$  factor in our denominator. Knowing that we have a zero

at  $x = 1$ , we know our denominator is made up of  $(x - 1)$  terms. To get the function that we want, we know we need a horizontal asymptote at 2 so our degree of our numerator and denominator must match. Experimenting with different powers we get  $(x - 1)^3$  and  $(x + 1)(x - 2)^2$ .

37.  $y = \frac{-(x-4)^3}{(x-4)(x+1)} + 1$ . To get a “hole” or a non-value at  $x = 4$ , having a  $\frac{(x-4)}{(x-4)}$  term will cancel everywhere with the exception of  $x = 4$  where the function will be undefined. Then, knowing that there is a vertical asymptote at  $x = -1$  we have a  $(x + 1)$  term in the denominator. Multiplying by  $(-3)$  and then adding 1 gives our desired shifts.

39. (a) To get the percentage of water (non-acid) in the beaker we take  $(n + 16)$  our total amount of water and divide by our total amount of solution  $(n + 20)$ . Then to get the percent of acid, we subtract the percent of water from 1, or  $1 - \frac{(n+16)}{(n+20)}$ .

(b) Using our equation from part (a), we get  $1 - \frac{(10+16)}{(10+20)} = 13.33\%$

(c) To get 4%, we use our equation from part (a) to solve:  $4 = 1 - \frac{n+16}{n+20} \rightarrow -3 = \frac{(n+16)}{(n+20)} \rightarrow -3n - 60 = n + 16 \rightarrow n = 19mL$ .

(d) As  $n \rightarrow \infty$ ,  $\frac{n+16}{n+20} \rightarrow 1$ , because the denominator and numerator have the same degree. So, as  $\rightarrow \infty$ ,  $1 - \frac{n+16}{n+20} \rightarrow 0$ . This means that our acid becomes insignificant compared to the water.

41. (a) We are given the form  $m(x) = \frac{ax+b}{cx+d}$  for the equation, so we need to find values for  $a$ ,  $b$ ,  $c$ , and  $d$ . Notice that there is more than one correct solution, since multiplying the numerator and denominator by the same value gives an equivalent function (for example, multiplying by, say,  $\frac{3}{3}$ , does not change the value of an expression). This means we are free to choose a value for one of the unknown numbers, but once that’s chosen, the values of the other three must follow from the given information. For this solution, let’s start by choosing  $c = 1$ .

We are told that when Oscar is “far down the hallway”, the meter reads 0.2. The word “far” implies that this is the long-run behavior, so the horizontal asymptote is  $y = 0.2$ . For the given form of  $m(x)$ , the horizontal asymptote has the form  $y = \frac{a}{c}$ , so  $\frac{a}{c} = 0.2$ . Since we previously

decided to let  $c = 1$ , we now know  $a = 0.2$ . Other language in the problem implies that  $m(6) = 2.3$  and  $m(8) = 4.4$  (assuming  $x = 0$  at the entrance to the room). We can plug in these values for  $x$  and  $m(x)$  to get the equations:  $2.3 = \frac{0.2*6+b}{6+d}$  and  $4.4 = \frac{0.2*8+b}{8+d}$ . Simplify these equations by multiplying both sides of each by the respective denominators. Solve the resulting system of equations (perhaps using substitution), which gives  $b = -10.4$  and  $d = -10$ , so the equation is  $m(x) = \frac{0.2x-10.4}{x-10}$ . (As previously stated, answers may vary, so long as the equations are equivalent. For example, a second possible solution is  $m(x) = \frac{x-52}{5x-50}$ . To show this is equivalent, multiply the previous answer by  $\frac{5}{5}$ .)

(b) The given values 10 and 100 are meter readings, so substitute them for  $m(x)$  and solve for  $x$ .  
When  $m(x) = 10$ :

$$10 = \frac{0.2x - 10.4}{x - 10}$$

$$10x - 100 = 0.2x - 10.4$$

$$9.8x = 89.6$$

$$x \approx 9.143$$

The algebra is similar when  $m(x) = 100$ , yielding  $x \approx 9.916$ .

(c) The meter reading increases as Oscar gets closer to the magnet. The graph of the function for (a) has a vertical asymptote at  $x = 10$ , for which the graph shoots up when approaching from the left, so the magnet is 10 feet into the room. This is consistent with our answers for (b), in which  $x$  gets closer to 10 as the meter reading increases.

43. (a) To solve for  $k$ , we plug  $c = 1$  and  $d = 20$  into our equation  $c = \frac{k}{d^2}$  and we get  $k = 400$ .

(b) To get from 15 miles/hour to feet/sec we use the following calculation:

$$(15) \left( \frac{1 \text{ mi}}{1} \right) \left( \frac{5280 \text{ ft}}{1 \text{ mi}} \right) \left( \frac{1}{\text{hour}} \right) \left( \frac{1 \text{ hour}}{60 \text{ min}} \right) \left( \frac{1 \text{ min}}{60 \text{ sec}} \right) = 22 \frac{\text{ft}}{\text{sec}}$$

( $33 - 22t$ ). Then, our total distance to the stoplight is  $d = \sqrt{10^2 + (33 - 22t)^2}$  which simplifies to  $d = \sqrt{1189 - 1452t + 484t^2}$ . So, our function is  $C(t) = \frac{400}{1189 - 1452t + 484t^2}$ .

(c) The light will shine on Olav the brightest when he has travelled 33 feet. To solve for what

time this will happen, we solve the equation  $22t = 33$  for  $t$ . So, the light will be the brightest at 1.5 seconds.

(d)  $2 = \frac{400}{1189 - 1452t + 484t^2}$  to solve for  $t$  we get  $200 = 1189 - 1452t + 484t^2$  or  $0 = 989 - 1452t + 484t^2$ . Using the quadratic formula, we get  $t = \frac{23}{22}$  and  $\frac{43}{22}$ .

### 3.5 Solutions to Exercises

1. Domain:  $x \geq 4$ . By determining the vertex of this transformed function as  $(4,0)$ , we know  $x$  has to be  $x \geq 4$  for  $f(x)$  to be a one-to-one non-decreasing function. To find the inverse:

$$y = (x - 4)^2$$

$$\pm\sqrt{y} = x - 4$$

$$-4 \pm \sqrt{y} = x$$

Since we restricted the domain of the function to  $x \geq 4$ , the range of the inverse function should be the same, telling us to use the positive case. So  $f^{-1}(y) = -4 + \sqrt{y}$ .

3. Domain:  $x \leq 0$ , because this parabola opens down with a vertex of  $(0, 12)$ . To find the inverse:

$$y = 12 - x^2$$

$$x^2 = 12 - y$$

$$x = \pm\sqrt{12 - y}$$

Since we restricted the domain of the function to  $x \leq 0$ , the range of the inverse function should be the same, telling us to use the negative case. So  $f^{-1}(y) = -\sqrt{12 - y}$ .

5. Domain: all real numbers, because this function is always one-to-one and increasing. To find the inverse:

$$y = 3x^3 + 1$$

$$y - 1 = 3x^3$$

$$\frac{y - 1}{3} = x^3$$

$$x = f^{-1}(y) = \sqrt[3]{\frac{y-1}{3}}$$

$$7. y = 9 + \sqrt{4x - 4}$$

$$y - 9 = \sqrt{4x - 4}$$

$$(y - 9)^2 = 4x - 4$$

$$(y - 9)^2 = 4x - 4$$

$$9. y = 9 + 2\sqrt[3]{x}$$

$$y - 9 = 2\sqrt[3]{x}$$

$$\frac{y-9}{2} = \sqrt[3]{x}$$

$$x = f^{-1}(y) = \left(\frac{y-9}{2}\right)^3$$

$$(y - 9)^2 + 4 = 4x$$

$$x = f^{-1}(y) = \frac{(y - 9)^2}{4} + 1$$

$$11. y = \frac{2}{x+8}$$

$$y(x + 8) = 2$$

$$xy + 8y = 2$$

$$x = f^{-1}(x) = \frac{2-8y}{y}$$

$$13. y = \frac{x+3}{x+7}$$

$$y(x + 7) = x + 3$$

$$xy + 7y = x + 3$$

$$xy - x = 3 - 7y$$

$$x(y - 1) = 3 - 7y$$

$$x = f^{-1}(x) = \frac{3-7y}{y-1}$$

15. Using the same algebraic methods as Problem 13, we get  $f^{-1}(y) = \frac{5y-4}{4y+3}$ .

17.  $v \approx 65.57$  mph. This problem is asking for the speed ( $v$ ) given the length ( $l$ ) so you can plug in 215 for  $L$  and solve.

19.  $v \approx 34.07$  mph. Refer to problem 17 (with  $r$  for radius instead of  $l$  for length)

21. Impose a coordinate system with the origin at the bottom of the ditch. Then the parabola will be in the form  $y = ax^2$ , and the points on either side at the top of the ditch are  $(-10, 10)$  and  $(10, 10)$ . Plugging either into the general form and solving for  $a$  gives  $a = 0.1$ . To find the  $x$ -coordinates where the water meets the edges of the ditch, plug 5 into  $y = 0.1x^2$  for  $y$ . Solving for  $x$  gives approximately 7.07. Note that this is just half of the width of the surface of the water, so the entire width is about 14.14 feet.

23. (a)  $h = -2x^2 + 124x$  Since the slope of the cliff is  $-4$ , the equation of the cliff is  $y = -4x$ . Then the equations relating the height  $h$  of the rocket above the sloping ground is the height of the ground subtracted from the height of the rocket.

(b) The maximum height of the rocket over the ground is at the vertex of the parabola. To find the vertex you first want to solve for the  $x$  coordinate of the vertex:  $\left(-\frac{b}{2a}\right)$ . So  $h = -2x^2 + 124x$ , then  $a = -2$ ,  $b = 124$ , so  $\left(-\frac{124}{2(-2)}\right) = x = 31$ . To find the vertex you can then plug in your  $x$  coordinate of the vertex into your function:  $h = -2(31)^2 + 124(31) = 1922$  feet. So the rocket's maximum height above the ground is 1922 feet.

(c) To find a function for  $x = g(h)$ , solve  $h = -2x^2 + 124x$  for  $x$ :

$$h = -2x^2 + 124x$$

$$2x^2 - 124x + h = 0$$

$$x = \frac{124 \pm \sqrt{15,376 - 8h}}{4} \text{ by the quadratic formula}$$

$x = g(h) = \frac{62 - \sqrt{3,844 - 2h}}{2}$  by reducing and taking the negative root in the numerator to give the lower of the two possible  $x$ -coordinates, since the rocket is going up on the left half of the parabola.

(d) The function given in (c) does not work when the function is going down. We would have had to choose the positive root in the numerator to give the right half of the parabola.

## 4.1 Solutions to Exercises

1. Linear, because the average rate of change between any pair of points is constant.
3. Exponential, because the difference of consecutive inputs is constant and the ratio of consecutive outputs is constant.
5. Neither, because the average rate of change is not constant nor is the difference of consecutive inputs constant while the ratio of consecutive outputs is constant.
7.  $f(x) = 11,000(1.085)^x$  You want to use your exponential formula  $f(x) = ab^x$  You know the initial value  $a$  is 11,000. Since  $b$ , your growth factor, is  $b = 1 \pm r$ , where  $r$  is the percent (written as a decimal) of growth/decay,  $b = 1.085$ . This gives you every component of your exponential function to plug in.
9.  $f(x) = 23,900(1.09)^x$   $f(8) = 47,622$ . You know the fox population is 23,900, in 2010, so that's your initial value. Since  $b$ , your growth factor is  $b = 1 \pm r$ , where  $r$  is the percent (written as a decimal) of growth/decay,  $b = 1.09$ . This gives you every component of your exponential function and produces the function  $f(x) = 23,900(1.09)^x$ . You're trying to evaluate the fox population in 2018, which is 8 years after 2010, the time of your initial value. So if you evaluate your function when  $x = 8$ , because  $2018 - 2010 = 8$ , you can estimate the population in 2018.
11.  $f(x) = 32,500(.95)^x$   $f(12) = \$17,561.70$ . You know the value of the car when purchased is 32,500, so that's your initial value. Since your growth factor is  $b = 1 \pm r$ , where  $r$  is the percent (written as a decimal) of growth/decay,  $b = .95$  This gives you every component of your exponential function produces the function  $f(x) = 32,500(.95)^x$ . You're trying to evaluate the value of the car 12 years after it's purchased. So if you evaluate your function when  $x = 12$ , you can estimate the value of the car after 12 years.



13. We want a function in the form  $f(x) = ab^x$ . Note that  $f(0) = ab^0 = a$ ; since  $(0, 6)$  is a given point,  $f(0) = 6$ , so we conclude  $a = 6$ . We can plug the other point  $(3, 750)$ , into  $f(x) = 6b^x$  to solve for  $b$ :  $750 = 6(b)^3$ . Solving gives  $b = 5$ , so  $f(x) = 6(5)^x$ .

15. We want a function in the form  $f(x) = ab^x$ . Note that  $f(0) = ab^0 = a$ ; since  $(0, 2000)$  is a given point,  $f(0) = 2000$ , so we conclude  $a = 2000$ . We can plug the other point  $(2, 20)$  into  $f(x) = 2000b^x$ , giving  $20 = 2000(b)^2$ . Solving for  $b$ , we get  $b = 0.1$ , so  $f(x) = 2000(.1)^x$ .

17.  $f(x) = 3(2)^x$  For this problem, you are not given an initial value, so using the coordinate points your given,  $(-1, \frac{3}{2})$ ,  $(3, 24)$  you can solve for  $b$  and then  $a$ . You know for the first coordinate point,  $(\frac{3}{2}) = a(b)^{-1}$ . You can now solve for  $a$  in terms of  $b$ :  $(\frac{3}{2}) = \frac{a}{b} \rightarrow (\frac{3b}{2}) = a$ . Once you know this, you can substitute  $(\frac{3b}{2}) = a$ , into your general equation, with your other coordinate point, to solve for  $b$ :  $24 = (\frac{3b}{2})(b)^3 \rightarrow 48 = 3b^4 \rightarrow 16 = b^4 \rightarrow b = 2$ . So you have now solved for  $b$ . Once you have done that you can solve for  $a$ , by using what you calculated for  $b$ , and one of the coordinate points your given:  $24 = a(2)^3 \rightarrow 24 = 8a \rightarrow a = 3$ . So now that you've solved for  $a$  and  $b$ , you can come up with your general equation:  $f(x) = 3(2)^x$ .

19.  $f(x) = 2.93(.699)^x$  For this problem, you are not given an initial value, so using the coordinate points you're given,  $(-2, 6)$ ,  $(3, 1)$  you can solve for  $b$  and then  $a$ . You know for the first coordinate point,  $1 = a(b)^3$ . You can now solve for  $a$  in terms of  $b$ :  $\frac{1}{b^3} = a$ . Once you know this, you can substitute  $\frac{1}{b^3} = a$ , into your general equation, with your other coordinate point, to solve for  $b$ :  $6 = \frac{1}{b^3}(b)^{-2} \rightarrow 6b^5 = 1 \rightarrow b^5 = \frac{1}{6} \rightarrow b = .699$ . So you have now solved for  $b$ . Once you have done that you can solve for  $a$ , by using what you calculated for  $b$ , and one of the coordinate points you're given:  $6 = a(.699)^{-2} \rightarrow 6 = 2.047a \rightarrow a = 2.93$ . So now that you've solved for  $a$  and  $b$ , you can come up with your general equation:  $f(x) = 2.93(.699)^x$

21.  $f(x) = \frac{1}{8}(2)^x$  For this problem, you are not given an initial value, so using the coordinate points you're given, (3,1), (5, 4) you can solve for  $b$  and then  $a$ . You know for the first coordinate point,  $1 = a(b)^3$ . You can now solve for  $a$  in terms of  $b$ :  $1/b^3 = a$ . Once you know this, you can substitute  $\frac{1}{b^3} = a$ , into your general equation, with your other coordinate point, to solve for  $b$ :  $4 = \frac{1}{b^3}(b)^5 \rightarrow 4 = b^2 \rightarrow b = 2$ . So you have now solved for  $b$ . Once you have done that you can solve for  $a$ , by using what you calculated for  $b$ , and one of the coordinate points your given:  $1 = a(2)^3 \rightarrow 1 = 8a \rightarrow a = 1/8$ . So now that you've solved for  $a$  and  $b$ , you can come up with your general equation:  $f(x) = \frac{1}{8}(2)^x$

23. 33.58 milligrams. To solve this problem, you want to use the exponential growth/decay formula,  $f(x) = a(b)^x$ , to solve for  $b$ , your growth factor. Your starting amount is  $a$ , so  $a=100$  mg. You are given a coordinate, (35,50), which you can plug into the formula to solve for  $b$ , your effective growth rate giving you your exponential formula  $f(x) = 100(0.98031)^x$  Then you can plug in your  $x = 54$ , to solve for your substance.

25. \$1,555,368.09 Annual growth rate: 1.39% To solve this problem, you want to use the exponential growth/decay formula  $f(x)=ab^x$  First create an equation using the initial conditions, the price of the house in 1985, to solve for  $a$ . You can then use the coordinate point you're given to solve for  $b$ . Once you've found  $a$ , and  $b$ , you can use your equation  $f(x)=110,000(1.0139)^x$  to predict the value for the given year.

27. \$4,813.55 To solve this problem, you want to use the exponential growth/decay formula  $f(x)=ab^x$  First create an equation using the initial conditions, the value of the car in 2003, to solve for  $a$ . You can then use the coordinate point you're given to solve for  $b$ . Once you've found  $a$ , and  $b$ , you can use your equation  $f(x)=38,000(.81333)^x$  to predict the value for the given year.

29. Annually: \$7353.84 Quarterly: \$47469.63 Monthly: \$7496.71 Continuously: \$7,501.44. Using the compound interest formula  $A(t)=a(1 + \frac{r}{R})^{Kt}$  you can plug in your starting amount,

\$4000 to solve for each of the three conditions, annually— $k = 1$ , quarterly— $k = 4$ , and monthly— $k = 12$ . You then need to plug your starting amount, \$4000 into the continuous growth equation  $f(x) = ae^{rx}$  to solve for continuous compounding.

31. APY = .03034  $\approx$  3.03% You want to use the APY formula  $f(x) = (1 + \frac{r}{K})^K - 1$  you are given a rate of 3% to find your  $r$  and since you are compounding quarterly  $K=4$

33.  $t = 7.4$  years To find out when the population of bacteria will exceed 7569 you can plug that number into the given equation as  $P(t)$  and solve for  $t$ . To solve for  $t$ , first isolate the exponential expression by dividing both sides of the equation by 1600, then take the  $\ln$  of both sides of the equation, utilizing the exponent property for logs to pull the variable out of the exponent, then use algebra to solve for  $t$ .

35. (a)  $w(t) = 1.1130(1.0464)^t$  For this problem, you are not given an initial value, since 1960 corresponds to 0, 1968 would correspond to 8 and so on, giving you the points (8,1.60) (16,2.30) you can use these points to solve for  $b$  and then  $a$ . You know for the first coordinate point,  $1.60 = ab^8$ . You can now solve for  $a$  in terms of  $b$ :  $\frac{1.60}{b^8} = a$ . Once you know this, you can substitute  $\frac{1.60}{b^8} = a$ , into your general equation, with your other coordinate point, to solve for  $b$ :  $2.30 = \frac{1.60}{b^8}(b)^{16} \rightarrow 1.60b^8 = 2.30 \rightarrow b^8 = \frac{2.30}{1.60} \rightarrow b = 1.0464$ . So you have now solved for  $b$ . Once you have done that you can solve for  $a$ , by using what you calculated for  $b$ , and one of the coordinate points you're given:  $2.30 = a(1.0464)^{16} \rightarrow 2.30 = 2.0664a \rightarrow a = 1.1130$ . So now that you've solved for  $a$  and  $b$ , you can come up with your general equation:  $w(t) = 1.1130(1.0464)^t$

(b) \$1.11 using the equation you found in part a you can find  $w(0)$

(c) The actual minimum wage is less than the model predicted, using the equation you found in part a you can find  $w(36)$  which would correspond to the year 1996

37. (a) 512 dimes the first square would have 1 dime which is  $2^0$  the second would have 2 dimes which is  $2^1$  and so on, so the tenth square would have  $2^9$  or 512 dimes

(b)  $2^{n-1}$  if  $n$  is the number of the square you are on the first square would have 1 dime which is  $2^{1-1}$  the second would have 2 dimes which is  $2^{2-1}$  the fifteenth square would have 16384 dimes which is  $2^{15-1}$

(c)  $2^{63}$ ,  $2^{64-1}$

(d) 9,223,372,036,854,775,808 mm

(e) There are 1 million millimeters in a kilometer, so the stack of dimes is about 9,223,372,036,855 km high, or about 9,223,372 million km. This is approximately 61,489 times greater than the distance of the earth to the sun.

## 4.2 Solutions to Exercises

1. b    3. a    5. e

7. The value of  $b$  affects the steepness of the slope, and graph D has the highest positive slope it has the largest value for  $b$ .

9. The value of  $a$  is your initial value, when your  $x = 0$ . Graph C has the largest value for  $a$ .

11. The function changes  $x$  to  $-x$ , which will reflect the graph across the  $y$ -axis.

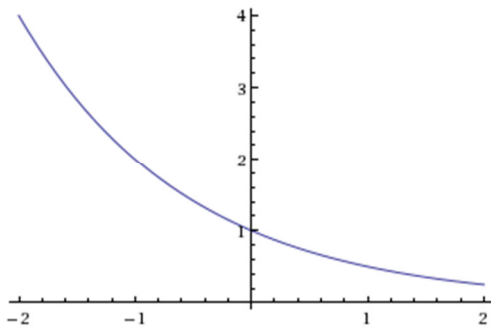

13. The function will shift the function three units up.

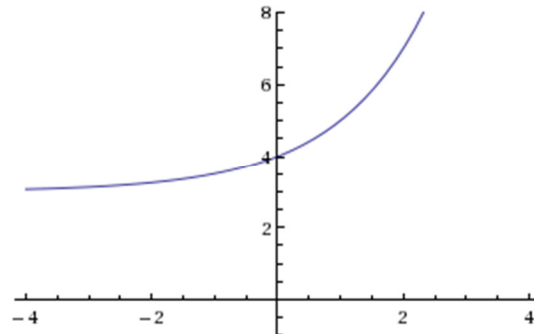

15. The function will shift the function two units to the right.

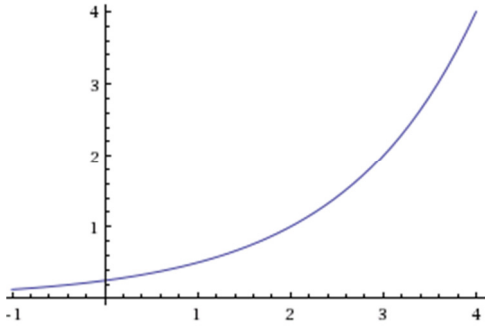

17.  $f(x) = 4^x + 4$       19.  $f(x) = 4^{(x+2)}$       21.  $f(x) = -4^x$
23. as  $x \rightarrow \infty, f(x) \rightarrow -\infty$ . When  $x$  is approaching  $+\infty, f(x)$  becomes negative because  $4^x$  is multiplied by a negative number.  
as  $x \rightarrow -\infty, f(x) = -1$ . As  $x$  approaches  $-\infty, f(x)$  approaches 1, because  $-5(4^{-x})$  will approach 0, which means  $f(x)$  approaches -1 as it's shifted down one.
25. as  $x \rightarrow \infty, f(x) \rightarrow -2$  As  $x$  approaches  $+\infty, f(x)$  approaches -2, because  $3\left(\frac{1}{2}\right)^x$  will approach 0, which means  $f(x)$  approaches -2 as it's shifted down 2.  
as  $x \rightarrow -\infty, f(x) \rightarrow +\infty$  because  $\left(\frac{1}{2}\right)^{-x} = (2)^x$  so  $f(x) \rightarrow \infty$ .
27. as  $x \rightarrow \infty, f(x) \rightarrow 2$  As  $x$  approaches  $+\infty, f(x)$  approaches 2, because  $3(4)^{-x}$  will approach 0, which means  $f(x)$  approaches 2 as it's shifted up 2.  
as  $x \rightarrow -\infty, f(x) \rightarrow \infty$  because  $(4)^{-x} = \left(\frac{1}{4}\right)^x$  so  $f(x) \rightarrow \infty$ .
29.  $f(x) = -2^{x+2} + 1$  flipped about the x-axis, horizontal shift 2 units to the left, vertical shift 1 unit up
31.  $f(x) = -2^{-x} + 2$  flipped about the x-axis, flipped about the y-axis, vertical shift 2 units up
33.  $f(x) = -2(3)^x + 7$  The form of an exponential function is  $y = ab^x + c$ . This equation has a horizontal asymptote at  $x = 7$  so we know  $c = 7$ , you can also now solve for  $a$  and  $b$  by choosing two other points on the graph, in this case (0,5) and (1,1), you can then plug (0,5) into your general equation and solve for  $a$  algebraically, and then use your second point to solve for  $b$ .

35.  $f(x) = 2\left(\frac{1}{2}\right)^x - 4$  The form of an exponential function is  $y = ab^x + c$ . This equation has a horizontal asymptote at  $x = -4$  so we know  $c = -4$ , you can also now solve for  $a$  and  $b$  by choosing two other points on the graph, in this case  $(0,-2)$  and  $(-1,0)$ , you can then plug  $(0,-2)$  into your general equation and solve for  $a$  algebraically, and then use your second point to solve for  $b$ .

### 4.3 Solutions to Exercises

1.  $4^m = q$  use the inverse property of logs  $\log_b c=a$  is equivalent to  $b^a=c$
3.  $a^c = b$  use the inverse property of logs  $\log_b c=a$  is equivalent to  $b^a=c$
5.  $10^t = v$  use the inverse property of logs  $\log_b c=a$  is equivalent to  $b^a=c$
7.  $e^n = w$  use the inverse property of logs  $\log_b c=a$  is equivalent to  $b^a=c$
9.  $\log_4 y = x$  use the inverse property of logs  $b^a=c$  is equivalent to  $\log_b c=a$
11.  $\log_c k = d$  use the inverse property of logs  $b^a=c$  is equivalent to  $\log_b c=a$
13.  $\log b = a$  use the inverse property of logs  $b^a=c$  is equivalent to  $\log_b c=a$
15.  $\ln h = k$  use the inverse property of logs  $b^a=c$  is equivalent to  $\log_b c=a$
17.  $x = 9$  solve using the inverse properties of logs to rewrite the logarithmic expression as the exponential expression  $3^2 = x$  then solve for  $x$
19.  $x = \frac{1}{8}$  solve using the inverse properties of logs to rewrite the logarithmic expression as the exponential expression  $2^{-3} = x$  then solve for  $x$
21.  $x = 1000$  solve using the inverse properties of logs to rewrite the logarithmic expression as the exponential expression  $10^3 = x$  then solve for  $x$

23.  $x = e^2$  solve using the inverse properties of logs to rewrite the logarithmic expression as the exponential expression  $e^2 = x$

25. 2 solve using the inverse properties of logs to rewrite the logarithmic expression as the exponential expression  $5^x = 25$  then solve for x

27.  $-3$  solve using the inverse properties of logs to rewrite the logarithmic expression as the exponential expression  $3^x = \frac{1}{27}$  then solve for x

29.  $\frac{1}{2}$  solve using the inverse properties of logs to rewrite the logarithmic expression as the exponential expression  $6^x = \sqrt{6}$  then solve for x

31. 4 solve using the inverse properties of logs to rewrite the logarithmic expression as the exponential expression  $10^x = 10,000$  then solve for x

33.  $-3$  solve using the inverse properties of logs to rewrite the logarithmic expression as the exponential expression  $10^x = 0.001$  then solve for x

35.  $-2$  solve using the inverse properties of logs to rewrite the logarithmic expression as the exponential expression  $e^x = e^{-2}$  then solve for x

37.  $x = -1.398$  use calculator

39.  $x = 2.708$  use calculator

41.  $x \approx 1.639$  Take the log or ln of both sides of the equation, utilizing the exponent property for logs to pull the variable out of the exponent, then use algebra to solve for x.

43.  $x \approx -1.392$  Take the log or ln of both sides of the equation, utilizing the exponent property for logs to pull the variable out of the exponent, then use algebra to solve for x.

45.  $x \approx 0.567$  Take the log or ln of both sides of the equation, utilizing the exponent property for logs to pull the variable out of the exponent, then use algebra to solve for x.

47.  $x \approx 2.078$  Take the log or ln of both sides of the equation, utilizing the exponent property for logs to pull the variable out of the exponent, then use algebra to solve for x.

49.  $x \approx 54.449$  First isolate the exponential expression by dividing both sides of the equation by 1000 to get it into  $b^a=c$  form, then take the log or ln of both sides of the equation, utilizing the exponent property for logs to pull the variable out of the exponent, then use algebra to solve for x.

51.  $x \approx 8.314$  First isolate the exponential expression by dividing both sides of the equation by 3 to get it into  $b^a=c$  form, then take the log or ln of both sides of the equation, utilizing the exponent property for logs to pull the variable out of the exponent, then use algebra to solve for x.

53.  $x \approx 13.412$  First isolate the exponential expression by dividing both sides of the equation by 50 to get it into  $b^a=c$  form, then take the log or ln of both sides of the equation, utilizing the exponent property for logs to pull the variable out of the exponent, then use algebra to solve for x.

55.  $x \approx .678$  First isolate the exponential expression by subtracting 10 from both sides of the equation and then dividing both sides by -8 to get it into  $b^a=c$  form, then take the log or ln of both sides of the equation, utilizing the exponent property for logs to pull the variable out of the exponent, then use algebra to solve for x.

57.  $f(t) = 300e^{-.094t}$  You want to change from the form  $f(t) = a(1 + r)^t$  to  $f(t) = ae^{kt}$ . From your initial conditions, you can solve for  $k$  by recognizing that, by using algebra,  $(1 + r) = e^k$ . In this case  $e^k = 0.91$  Then take the log or ln of both sides of the equation, utilizing the exponent property for logs to pull the variable out of the exponent, and then use algebra to solve for k. You then have all the pieces to plug into your continuous growth equation.

59.  $f(t) = 10e^{.0392t}$  You want to change from the form  $f(t) = a(1 + r)^t$  to  $f(t) = ae^{kt}$ . From your initial conditions, you can solve for  $k$  by recognizing that, by using algebra,  $(1 + r) = e^k$ . In this case  $e^k = 1.04$  Then take the log or ln of both sides of the equation, utilizing



the exponent property for logs to pull the variable out of the exponent, and then use algebra to solve for  $x$ . You then have all the pieces to plug into your continuous growth equation.

61.  $f(t) = 150(1.062)^t$  You want to change from the form  $f(t) = ae^{kt}$  to  $f(t) = a(1+r)^t$ . You can recognize that, by using algebra,  $(1+r) = e^k$ . You can then solve for  $b$ , because you are given  $k$ , and you know that  $b = (1+r)$ . Once you've calculated  $b = 1.06184$ , you have solved for all your variables, and can now put your equation into annual growth form.

63.  $f(t) = 50(.988)^t$  You want to change from the form  $f(t) = ae^{kt}$  to  $f(t) = a(1+r)^t$ . You can recognize that, by using algebra,  $(1+r) = e^k$ . You can then solve for  $b$ , because you are given  $k$ , and you know that  $b = (1+r)$ . Once you've calculated  $b = .988072$ , you have solved for all your variables, and can now put your equation into annual growth form.

65. 4.78404 years You want to use your exponential growth formula  $y = ab^t$  and solve for  $t$ , time. You are given your initial value  $a = 39.8$  million and we know that  $b = (1+r)$  you can solve for  $b$  using your rate,  $r = 2.6\%$  so  $b = 1.026$ . You want to solve for  $t$  when  $f(t) = 45$  million so your formula is  $45 = 39.8(1.026)^t$ . To solve for  $t$ , first isolate the exponential expression by dividing both sides of the equation by 39.8, then take the log or  $\ln$  of both sides of the equation, utilizing the exponent property for logs to pull the variable out of the exponent, then use algebra to solve for  $t$ .

67. 74.2313 years You want to use your exponential growth formula  $y = ab^t$  and first solve for  $b$ . You are given your initial value  $a = 563,374$  and you know that after 10 years the population grew to 608,660 so you can write your equation  $608,660 = 563,374(b)^{10}$  and solve for  $b$  getting 1.00776. Now you want to find  $t$  when  $f(t) = 1,000,000$  so you can set up the equation  $1,000,000 = 563,364(1.00776)^t$ . To solve for  $t$ , first isolate the exponential expression by dividing both sides of the equation by 563,364, then take the log or  $\ln$  of both sides of the equation, utilizing the exponent property for logs to pull the variable out of the exponent, then use algebra to solve for  $t$ .

69. 34.0074 hrs You want to use your exponential decay formula  $y = ab^t$  and first solve for  $b$ . You are given your initial value  $a = 100\text{mg}$  and you know that after 4 hours the substance decayed

to 80mg so you can write your equation  $80=100(b)^4$  and solve for b getting .945742. Now you want to find t when  $f(t)=15$  so you can set up the equation  $15=100(.945742)^t$ . To solve for t, first isolate the exponential expression by dividing both sides of the equation by 100, then take the log or ln of both sides of the equation, utilizing the exponent property for logs to pull the variable out of the exponent, then use algebra to solve for t.

71. 13.5324 months You want to use your compound interest formula  $A(t)= a(1 + \frac{r}{k})^{kt}$  to solve for t when  $f(t)=1500$ . You are given your initial value  $a=1000$ , a rate of  $r=.03$ , and it compounds monthly so  $k=12$ . You can then write your equation as  $1500=1000(1 + \frac{.03}{12})^{12t}$  and solve for t. To solve for t, first isolate the exponential expression by dividing both sides of the equation by 1000, then take the log or ln of both sides of the equation, utilizing the exponent property for logs to pull the variable out of the exponent, then use algebra to solve for t.

#### 4.4 Solutions to Exercises

1.  $\log_3 4$  simplify using difference of logs property
3.  $\log_3 7$  the -1 can be pulled inside the log by the exponential property to raise  $\frac{1}{7}$  to the  $-1$
5.  $\log_3 5$  simplify using sum of logs property
7.  $\log_7 2$  the  $\frac{1}{3}$  can be pulled inside the log by the exponential property to raise 8 to the  $\frac{1}{3}$
9.  $\log(6x^9)$  simplify using sum of logs property
11.  $\ln(2x^7)$  simplify using difference of logs property
13.  $\log(x^2(x + 1)^3)$   $x$  can be raised to the 2<sup>nd</sup> power, and  $(x + 1)$  can be raised to the 3<sup>rd</sup> power via the exponential property, these two arguments can be multiplied in a single log via the sum of logs property

15.  $\log\left(\frac{xz^3}{\sqrt{y}}\right)$  y can be raised to the  $-\frac{1}{2}$  power, and z to the 3<sup>rd</sup> power via the exponential property, then these three arguments can be multiplied in a single log via the sum of logs property
17.  $15 \log(x) + 13 \log(y) - 19 \log(z)$  expand the logarithm by adding  $\log(x^{15})$  and  $\log(y^{13})$  (sum property) and subtracting  $\log(z^{19})$  (difference property) then pull the exponent of each logarithm in front of the logs (exponential property)
19.  $4 \ln(b) - 2 \ln(a) - 5 \ln(c)$  expand the logarithm by adding  $\ln(b^{-4})$  and  $\ln(c^5)$  (sum property) and subtracting that from  $\ln(a^{-2})$  (difference property) then pull the exponent of each logarithm in front of the logs (exponential property)
21.  $\frac{3}{2} \log(x) - 2 \log(y)$  expand the logarithm by adding  $\log(x^{\frac{3}{2}})$  and  $\log(y^{-4})$  (sum property) then pull the exponent of each logarithm in front of the logs (exponential property)
23.  $\ln(y) + \left(\frac{1}{2} \ln(y) - \frac{1}{2} \ln(1 - y)\right)$  expand the logarithm by subtracting  $\ln(y^{\frac{1}{2}})$  and  $\ln\left((1 - y)^{\frac{1}{2}}\right)$  (difference property) and adding  $\ln(y)$  (sum property) then pull the exponent of each logarithm in front of the logs (exponential property)
25.  $2 \log(x) + 3 \log(y) + \frac{2}{3} \log(x) + \frac{5}{3} \log(y)$  expand the logarithm by adding  $\log(x^2)$ ,  $\log(y^3)$ ,  $\log(x^{\frac{2}{3}})$  and  $\log(y^{\frac{5}{3}})$  then pull the exponent of each logarithm in front of the logs (exponential property)
27.  $x \approx -0.7167$  Take the log or ln of both sides of the equation, utilizing the exponent property for logs to pull the variable out of the exponent, remembering to keep parenthesis on  $(4x-7)$  and  $(9x-6)$ , and then use algebra to solve for x.
29.  $x \approx -6.395$  divide both sides by 17 and  $(1.16)^x$  using properties of exponents, then take the log or ln of both sides of the equation, utilizing the exponent property for logs to pull the variable out of the exponent and then use algebra to solve for x

31.  $t \approx 17.329$  divide both sides by 10 and  $e^{(.12t)}$  using properties of exponents, then  $\ln$  both sides of the equation, utilizing the exponent property for logs to pull the variable out of the exponent, remembering that  $\ln(e)=1$ , and then use algebra to solve for  $t$
33.  $x = \frac{2}{7}$  rewrite as an exponential expression using the inverse property of logs and a base of 2 and then use algebra to solve for  $x$
35.  $x = \frac{1}{3e} \approx 0.1226$  subtract 3 from both sides of the equation and then divide both sides by 2, then rewrite as an exponential expression using the inverse property of logs and a base of  $e$  and then use algebra to solve for  $x$
37.  $x = \sqrt[3]{100} \approx 4.642$  rewrite as an exponential expression using the inverse property of logs and a base of 10 and then use algebra to solve for  $x$
39.  $x \approx 30.158$  combine the expression into a single logarithmic expression using the sum of logs property, then rewrite as an exponential expression using the inverse property of logs and a base of 10 and then use algebra to solve for  $x$
41.  $x = -\frac{26}{9} \approx -2.8889$  combine the expression into a single logarithmic expression using the difference of logs property, then rewrite as an exponential expression using the inverse property of logs and a base of 10 and then use algebra to solve for  $x$
43.  $x \approx -.872983$  combine the expression into a single logarithmic expression using the difference of logs property, then rewrite as an exponential expression using the inverse property of logs and a base of 6 and then use algebra to solve for  $x$
45.  $x = \frac{12}{11}$  combine the expression into a single logarithmic expression using the difference of logs property and the sum of logs property, then rewrite as an exponential expression using the inverse property of logs and a base of 10 and then use algebra to solve for  $x$

47.  $x = 10$  combine the expression into a single logarithmic expression using the difference of logs property and the sum of logs property, then rewrite as an exponential expression using the inverse property of logs and a base of 10 and then use algebra to solve for  $x$

### 4.5 Solutions to Exercises

1. Domain:  $x > 5$ , vertical asymptote:  $x = 5$ .

3. Domain:  $x < 3$ , vertical asymptote:  $x = 3$ .

5. Domain:  $x > -\frac{1}{3}$ , vertical asymptote:  $x = -\frac{1}{3}$ .

7. Domain:  $x < 0$ , vertical asymptote:  $x = 0$ .

9.

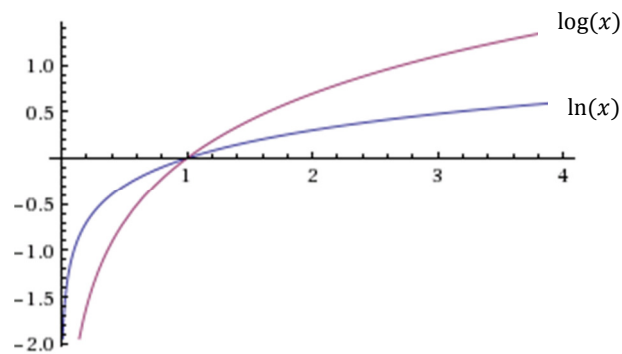

11.

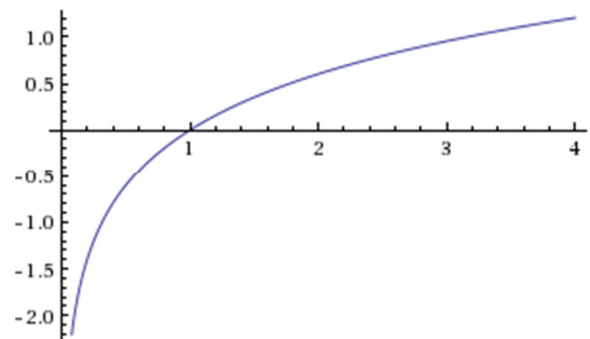

13.

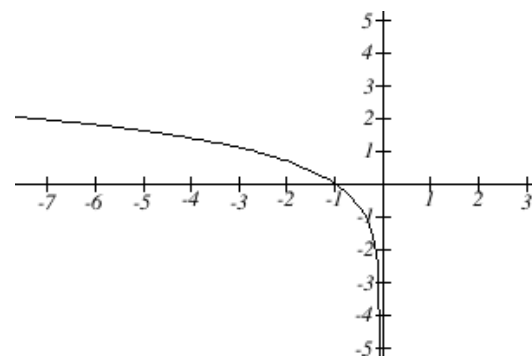

15.

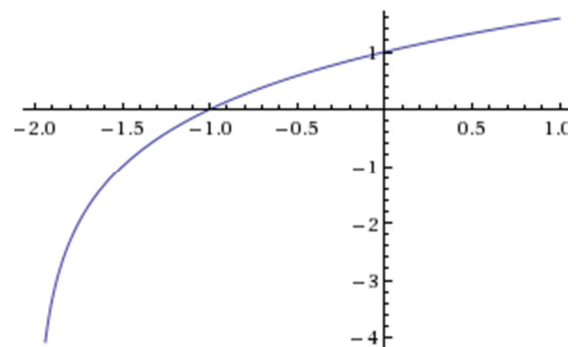

17.  $f(x) = 3.3219 \log(1 - x)$  Use the formula  $f(x) = a \log(x) + k$  and assume the function has a base of 10, first apply horizontal and vertical transformations if there are any, in this case a flip about the y-axis and a shift right 1, then to find the coefficient in front of the log plug in a given point  $(-1,1)$  in this case, and solve for  $a$  algebraically

19.  $f(x) = -6.2877 \log(x + 4)$  Use the formula  $f(x) = a \log(x) + k$  and assume the function has a base of 10, first apply horizontal and vertical transformations if there are any, in this case a shift left 4, then to find the coefficient in front of the log plug in a given point  $(-1,-3)$  in this case, and solve for  $a$  algebraically

21.  $f(x) = 4.9829 \log(x + 2)$  Use the formula  $f(x) = a \log(x) + k$  and assume the function has a base of 10, first apply horizontal and vertical transformations if there are any, in this case a shift left 2, then to find the coefficient in front of the log plug in a given point  $(2,3)$  in this case, and solve for  $a$  algebraically

23.  $f(x) = -3.3219 \log(5 - x)$  Use the formula  $f(x) = a \log(x) + k$  and assume the function has a base of 10, first apply horizontal and vertical transformations if there are any, in this case a flip about the y-axis and a shift right 5, then to find the coefficient in front of the log plug in a given point  $(0,-2)$  in this case, and solve for  $a$  algebraically

## 4.6 Solutions to Exercises

1. 23.93 min. You're solving for time, where you are given an initial value when  $t = 0$ . You need to first solve for your constant  $k$ , by plugging in one of your coordinates that gives you a  $t$ , and an  $f(t)$ . From there, you need to solve for  $t$  when  $f(t) = 2$  mg. You can use these conditions, to solve for  $t$ .

3. 13.01 mg. You're solving for time, where you are given an initial value when  $t = 0$ . You need to first solve for your constant  $k$ , by plugging in one of your coordinates that gives you a  $t$ , and an  $f(t)$ . From there, you need to solve for  $t$  when  $f(t) = 200$ mg. You can use these conditions, to solve for  $t$ .

5. Initial amount: 9.986mg .0802mg after 3 days. You want to use the half-life formula to solve for the initial amount, as well as the amount when  $t = 3$ . You first need to solve for  $k$ , by using your half life. Once you've done that, you can solve for  $a$  (your initial value), by plugging in the coordinate points you are given. You can then plug in your time  $t = 3$ , to solve for  $f(t)$ .

7. 75.49 min. You are trying to solve for your half life. You first need to solve for your rate of decay,  $k$ , by using the information your given, and plugging it into your general equation,  $\frac{1}{2}a = ae^{rt}$ . By then taking the natural log of both sides you can solve for  $k$ , and with that given information solve for your half life.

9. 422.169 years ago. You are trying to solve for your time  $t$  when there is 60% of carbon present in living trees in your artifact. You first need to solve for your rate of decay,  $k$ , by using the information your given, and plugging it into your general equation,  $\frac{1}{2}a = ae^{rt}$ . By then taking the natural log of both sides you can solve for  $k$ , and with that given information solve for time.

11. (a) 23,700 bacteria.

(b) 14,962 bacteria. You want to use a formula for doubling time for this problem. You need to first solve for  $r$ , your continuous growth rate. Using the information you are given you can plug in your values from the original equation  $n(t) = ae^{rt}$ , then take the natural log of both sides to solve for  $r$ . Once you've solved for  $r$  you can use the equation to solve for amount of bacteria after your two given times.

13. (a) 611 bacteria. (b) 26.02 min. (c) 10,406 bacteria. (d) 107.057 min.

To solve part (a) of this problem, you need to first make two equations with the 2 points your given to solve for  $k$  algebraically by manipulating the functions so  $k$  is the only variable. Once you've solved for  $k$ , you can solve part (a), and then solve for the doubling time by using the general equation  $n(t) = ae^{rt}$ , and plugging in the information you're given, and solve part (b). You can then plug in given values to solve for (a), (b), (c), and (d).

15. Doubling time  $t \approx 23.19$  years. We can use the compound interest equation from Section 4.1,  $A(t) = a \left(1 + \frac{r}{k}\right)^{kt}$ . To find the doubling time, since  $A(t)$  represents the final amount after time  $t$  with initial amount  $a$ , we can modify this equation to  $2a = a \left(1 + \frac{r}{k}\right)^{kt}$  which, since the  $a$ 's cancel, equals  $2 = \left(1 + \frac{r}{k}\right)^{kt}$ . Plugging in the appropriate values gives  $2 = \left(1 + \frac{0.03}{4}\right)^{4t}$ . To solve for the doubling time  $t$ , we must take the log of both sides and use properties of logs.

17. 53.258 hours. For this problem, you can use the coordinate point your given, and plug in another value for  $t$  to get a second plotted point. Once you've done that, you can use the general formula  $(t) = ab^t$ , where you know your  $a$ , and can then plug in values to solve for  $b$ . Once you've done that you can find the doubling period by using the equation  $2a = ab^t$ , and taking the log of both sides.

19. (a) 134.2°F (b) 1.879 hours, or 112.7 min.

You want to use the formula for Newton's law of cooling, where  $T_s$  is the outside environment's temperature,  $a$  is a constant, and  $k$  is the continuous rate of cooling. You can first solve for  $a$  for evaluating  $T(t)$  when  $t = 0$ .  $165 = ae^{0k} + 75$ . Solving for  $a$  gives  $a = 90$ . Use the temperature after half an hour to find  $k$ . (This solution is using hours as the units for  $t$ ; you could also allow the units to be minutes, which would lead to a different value of  $k$ .)

$$145 = 90e^{0.5k} + 75$$

$$\frac{7}{9} = e^{0.5k}$$

$$\ln\left(\frac{7}{9}\right) = 0.5k$$

$$k \approx -0.5026$$

Then  $T(t) \approx 90e^{-0.5026t} + 75$ . Use this formula to solve (a) and (b), substituting  $t = \frac{5}{6}$  hours for (a), and  $T(t) = 110$  for (b). The steps to solve for  $t$  in (b) is similar to what we did to find  $k$  above.





hours. Given the equation, you can plug in your time to solve for after 1 hour. You can then use the doubling formula to solve for  $t$ , by taking the natural log of both sides.

35. (a)  $M(p)$  is the top graph  $H(p)$  is the bottom graph  
 (b) 0.977507%  
 (c)  $H(t) = 32.4\%$ ,  $M(t) = 95.2\%$   
 (d) 20 torrs: 62.8%, 40 torrs: 20.6%, 60 torrs: 7.1%

You can evaluate which graph is which by plugging in values for  $t$  in each equation, and figuring out which graph is which. By plugging in 100 for  $p$ , you can solve for the level of oxygen saturation. You want to evaluate each equation at  $p = 20$  to compare the level of hemoglobin. By following the definition of efficiency of oxygen, you want to evaluate both equations at  $p = 20, 40, 60$ , and then subtract  $H(p)$  from  $M(p)$ .

37. (a)  $C(t) = C_0 e^{.03466t}$  (b)  $t = 433.87$  hours or  $t \approx 18$  days

To find a formula, you can use the information that  $C(t) = 2$  when  $t = 20$ , and  $C_0 = 1$ . Using this information you can take the natural log of both sides to solve for your  $k$ . Once you've solved for  $k$ , you can come up with your general equation. For (b), you know  $V = \frac{3}{4} \pi r^3$ , where you can substitute your know radius in for  $r$ . You can use this information to solve for your  $C_0$ . Once you've done this you can set the equation  $C(t) = 1$ , and take the natural log of both sides to solve for  $t$ .

39. Since the number of termites and spiders are growing exponentially, we can model them as  $T(t) = ab^t$  and  $S(t) = cd^t$ , respectively. We know the population when you move in (when  $t = 0$ ) is 100. Then  $100 = ab^0$ , so  $a = 100$ . We also are given that there are 200 termites after 4 days, so  $200 = 100b^4 \rightarrow 2 = b^4 \rightarrow b = 2^{1/4} \approx 1.1892$ . Then our model is  $T(t) = 100(1.1892)^t$ . We can then use this formula to find  $S(3) = \frac{1}{2}T(3) \approx 84$  and  $S(8) = \frac{1}{4}T(8) \approx 100$ . Then  $84 = cd^3$  and  $100 = cd^8$ . Then:

$$\frac{100}{84} = \frac{cd^8}{cd^3} \rightarrow d^5 \approx 1.1905 \rightarrow d \approx 1.0355$$

$$84 = c(1.0355)^3 \rightarrow c \approx 75.6535$$

Since  $c$  represents the initial population of spiders, which should be a whole number, we'll round  $c$  to 76, so our model is  $S(t) = 76(1.0355)^t$ . To find when it triples, let  $S(t) = 3 \cdot 76 = 228$ .

Then  $228 = 76(1.0355)^t \rightarrow 3 = (1.0355)^t \rightarrow t = \frac{\ln(3)}{\ln(1.0355)} \approx 31.5$  days.

## 4.7 Solutions to Exercises

1. Graph: We need to find 5 points on the graph, and then calculate the logarithm of the output value. Arbitrarily choosing 5 input values, we get ordered pairs  $(x, y) = (x, \log(f(x)))$

$x$	$f(x)$	$\log(f(x))$	$(x, y)$
-5	$4(1.3)^{-5}$ $\approx 1.07$	$\log(1.07) =$ 0.029	$(-5, 0.029)$
-3	$4(1.3)^{-3}$ $\approx 1.82$	0.260	$(-3, 0.260)$
0	$4(1.3)^0 = 4$	0.602	$(0, 0.602)$
3	$4(1.3)^3$ $\approx 8.78$	0.943	$(3, 0.943)$
5	$4(1.3)^5$ $\approx 14.85$	1.171	$(5, 1.171)$

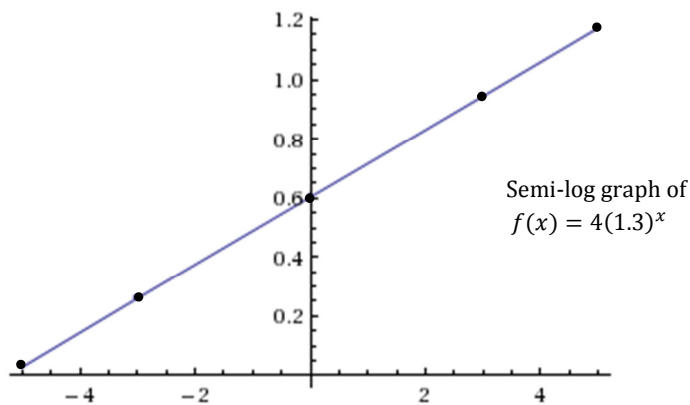

Equation:  $\log(f(x)) = .4139x + .0021$ . This is in the form  $\log(f(x)) = \log(a) + x\log(b)$ , where  $\log(a)$  is the vertical intercept and  $\log(b)$  is the slope. You can solve for the  $y$ -intercept by setting  $x = 0$  and then find another point to calculate the slope, and then put it into the form  $\log(f(x)) = mx + b$ .

3. Graph: Refer to Problem (1)

$(x, y)$
$(-5, 4.49)$
$(-3, 3.09)$
$(0, 1)$
$(3, -1.09)$
$(5, -2.49)$

Semi-log graph of  
 $f(x) = 10(0.2)^x$

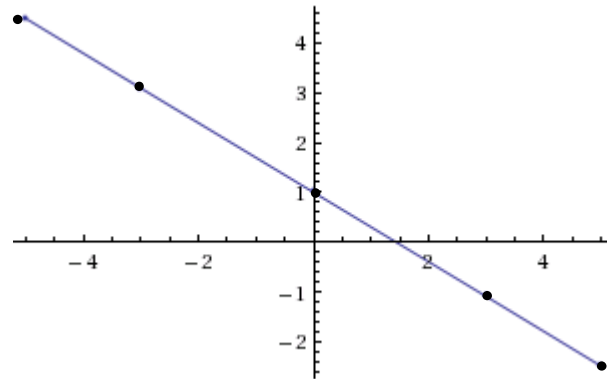

Equation:  $\log(f(x)) = -.699x + 1$ . This is in the form  $\log(f(x)) = \log(a) + x\log(b)$ , where  $\log(a)$  is the vertical intercept and  $\log(b)$  is the slope. You can solve for the  $y$ -intercept by setting  $x = 0$  and then find another point to calculate the slope, and then put it into the form  $\log(f(x)) = mx + b$ .

5.  $f(x) = \frac{(1.648)^x}{e}$  You want to look at your graph to solve for your  $y$ -intercept, and then find another point on the graph so you can calculate the slope, to find the linear formula. Once you've found that, because this is a semi-natural log graph, you would want to rewrite it as the natural log exponential and then simplify.

7.  $y(x) = 0.01(0.1)^x$  You want to look at your graph to solve for your  $y$  intercept, and then find another point on the graph so you can calculate the slope, to find the linear formula. Once you've found that, because this is a semi- log graph, you would want to rewrite it as the log exponential and then simplify.

9.  $y(x) = 776.25(1.426)^x$  You first want to calculate every  $\log(y)$  for your  $y$  values, and then from there you can use technology to find a linear equation. Once you've found that, because this is a semi- log graph, you would want to rewrite it as the log exponential and then simplify.

11.  $y(x) = 724.44(.738)^x$  You first want to calculate every  $\log(y)$  for your  $y$  values, and then from  $t$  here you can use technology to find a linear equation. Once you've found that, because this is a semi-log graph, you would want to rewrite it as the log exponential and then simplify.

13. (a)  $y = 54.954(1.054)^x$  (b) \$204.65 billion in expenditures

For part (a), You first want to calculate every  $\log(y)$  for your  $y$  values, and then from  $t$  here you can use technology to find a linear equation. Once you've found that, because this is a semi-log graph, you would want to rewrite it as the log exponential and then simplify. For part (b), your evaluating your function at  $t = 25$ , so plug that in for your equation to solve for  $y$ .

15. Looking at a scatter plot of the data, it appears that an exponential model is better. You first want to calculate every  $\log(y)$  for your  $y$  values, and then from  $t$  you can use technology to find a linear equation. Once you've found that, because this is a semi-log graph, you want to rewrite it as the log exponential and then simplify, which gives  $y(x) = 7.603(1.016)^x$ . The evaluate your function at  $t = 24$ , so plug that in for your equation to get 11.128 cents per kilowatt hour.

## 5.1 Solutions to Exercises

1.  $D = \sqrt{(5 - (-1))^2 + (3 - (-5))^2} = \sqrt{(5 + 1)^2 + (3 + 5)^2} = \sqrt{6^2 + 8^2} = \sqrt{100} = 10$

3. Use the general equation for a circle:

$$(x - h)^2 + (y - k)^2 = r^2$$

We set  $h = 8$ ,  $k = -10$ , and  $r = 8$ :

$$(x - 8)^2 + (y - (-10))^2 = 8^2$$

$$(x - 8)^2 + (y + 10)^2 = 64$$

5. Since the circle is centered at  $(7, -2)$ , we know our equation looks like this:

$$(x - 7)^2 + (y - (-2))^2 = r^2$$

$$(x - 7)^2 + (y + 2)^2 = r^2$$

What we don't know is the value of  $r$ , which is the radius of the circle. However, since the circle passes through the point  $(-10, 0)$ , we can set  $x = -10$  and  $y = 0$ :

$$((-10) - 7)^2 + (0 + 2)^2 = r^2$$

$$(-17)^2 + 2^2 = r^2$$

Flipping this equation around, we get:

$$r^2 = 289 + 4$$

$$r^2 = 293$$

Note that we actually don't need the value of  $r$ ; we're only interested in the value of  $r^2$ . Our final equation is:

$$(x - 7)^2 + (y + 2)^2 = 293$$

7. If the two given points are endpoints of a diameter, we can find the length of the diameter using the distance formula:

$$d = \sqrt{(8-2)^2 + (10-6)^2} = \sqrt{6^2 + 4^2} = \sqrt{52} = 2\sqrt{13}$$

Our radius,  $r$ , is half this, so  $r = \sqrt{13}$  and  $r^2 = 13$ . We now need the center  $(h, k)$  of our circle.

The center must lie exactly halfway between the two given points:  $h = \frac{8+2}{2} = \frac{10}{2} = 5$  and

$k = \frac{10+6}{2} = \frac{16}{2} = 8$ . So:

$$(x - 5)^2 + (y - 8)^2 = 13$$

9. This is a circle with center  $(2, -3)$  and radius 3:

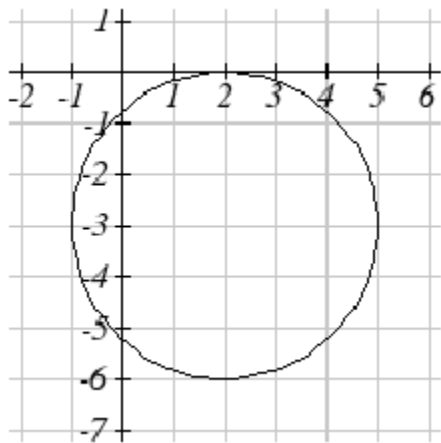

11. The equation of the circle is:

$$(x - 2)^2 + (y - 3)^2 = 3^2$$

The circle intersects the y-axis when  $x = 0$ :

$$(0 - 2)^2 + (y - 3)^2 = 3^2$$

$$(-2)^2 + (y - 3)^2 = 9$$

$$4 + (y - 3)^2 = 9$$

$$(y - 3)^2 = 5$$

$$y - 3 = \pm\sqrt{5}$$

The y intercepts are  $(0, 3 + \sqrt{5})$  and  $(0, 3 - \sqrt{5})$ .

13. The equation of the circle is:

$$(x - 0)^2 + (y - 5)^2 = 3^2, \text{ so } x^2 + (y - 5)^2 = 9.$$

The line intersects the circle when  $y = 2x + 5$ , so substituting for  $y$ :

$$x^2 + ((2x + 5) - 5)^2 = 9$$

$$x^2 + (2x)^2 = 9$$

$$5x^2 = 9$$

$$x^2 = 9/5$$

$$x = \pm \sqrt{9/5}$$

Since the question asks about the intersection in the first quadrant,  $x$  must be positive.

Substituting  $x = \sqrt{9/5}$  into the linear equation  $y = 2x + 5$ , we find the intersection at

$(\sqrt{9/5}, 2\sqrt{9/5} + 5)$  or approximately  $(1.34164, 7.68328)$ . (We could have also substituted

$x = -\sqrt{9/5}$  into the original equation for the circle, but that's more work.)

15. The equation of the circle is:

$$(x - (-2))^2 + (y - 0)^2 = 3^2, \text{ so } (x + 2)^2 + y^2 = 9.$$

The line intersects the circle when  $y = 2x + 5$ , so substituting for  $y$ :

$$(x + 2)^2 + (2x + 5)^2 = 9$$

$$x^2 + 4x + 4 + 4x^2 + 20x + 25 = 9$$

$$5x^2 + 24x + 20 = 0$$

This quadratic formula gives us  $x \approx -3.7266$  and  $x \approx -1.0734$ . Plugging these into the linear equation gives us the two points  $(-3.7266, -2.4533)$  and  $(-1.0734, 2.8533)$ , of which only the second is in the second quadrant. The solution is therefore  $(-1.0734, 2.8533)$ .

17. Place the transmitter at the origin  $(0, 0)$ . The equation for its transmission radius is then:

$$x^2 + y^2 = 53^2$$



Your driving path can be represented by the linear equation through the points (0, 70) (70 miles north of the transmitter) and (74, 0) (74 miles east):

$$y = -\frac{35}{37}(x - 74) = -\frac{35}{37}x + 70$$

The fraction is going to be cumbersome, but if we're going to approximate it on the calculator, we should use a number of decimal places:

$$y = -0.945946x + 70$$

Substituting  $y$  into the equation for the circle:

$$x^2 + (-0.945946x + 70)^2 = 2809$$

$$x^2 + 0.894814x^2 - 132.43244x + 4900 = 2809$$

$$1.894814x^2 - 132.43244x + 2091 = 0$$

Applying the quadratic formula,  $x \cong 24.0977$  and  $x \cong 45.7944$ . The points of intersection (using the linear equation to get the  $y$ -values) are (24.0977, 47.2044) and (45.7944, 26.6810).

The distance between these two points is:

$$d = \sqrt{(45.7944 - 24.0977)^2 + (26.6810 - 47.2044)^2} \approx 29.87 \text{ miles.}$$

19. Place the circular cross section in the Cartesian plane with center at (0, 0); the radius of the circle is 15 feet. This gives us the equation for the circle:

$$x^2 + y^2 = 15^2$$

$$x^2 + y^2 = 225$$

If we can determine the coordinates of points A, B, C and D, then the width of deck A's "safe zone" is the horizontal distance from point A to point B, and the width of deck B's

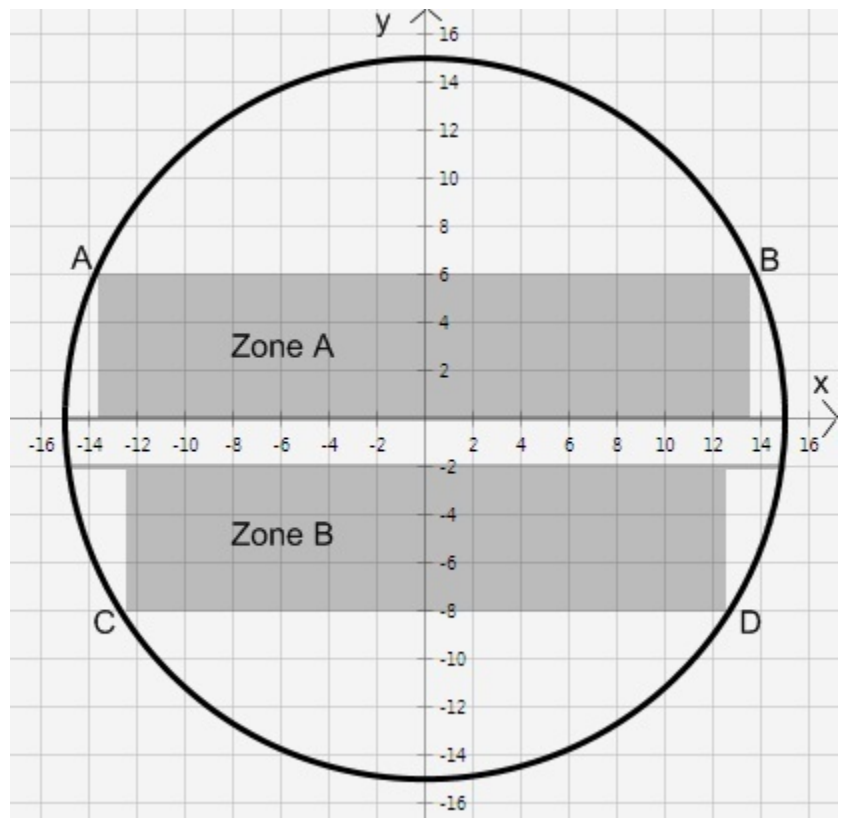

“safe zone” is the horizontal distance from point C to point D.

The line connecting points A and B has the equation:

$$y = 6$$

Substituting  $y = 6$  in the equation of the circle allows us to determine the x-coordinates of points A and B:

$$x^2 + 6^2 = 225$$

$$x^2 = 189$$

$x = \pm\sqrt{189}$ , and  $x \approx \pm 13.75$ . Notice that this seems to agree with our drawing. Zone A stretches from  $x \approx -13.75$  to  $x \approx 13.75$ , so its width is about 27.5 feet.

To determine the width of zone B, we intersect the line  $y = -8$  with the equation of the circle:

$$x^2 + (-8)^2 = 225$$

$$x^2 + 64 = 225$$

$$x^2 = 161$$

$$x = \pm\sqrt{161}$$

$$x \approx \pm 12.69$$

The width of zone B is therefore approximately 25.38 feet. Notice that this is less than the width of zone A, as we expect.

21.

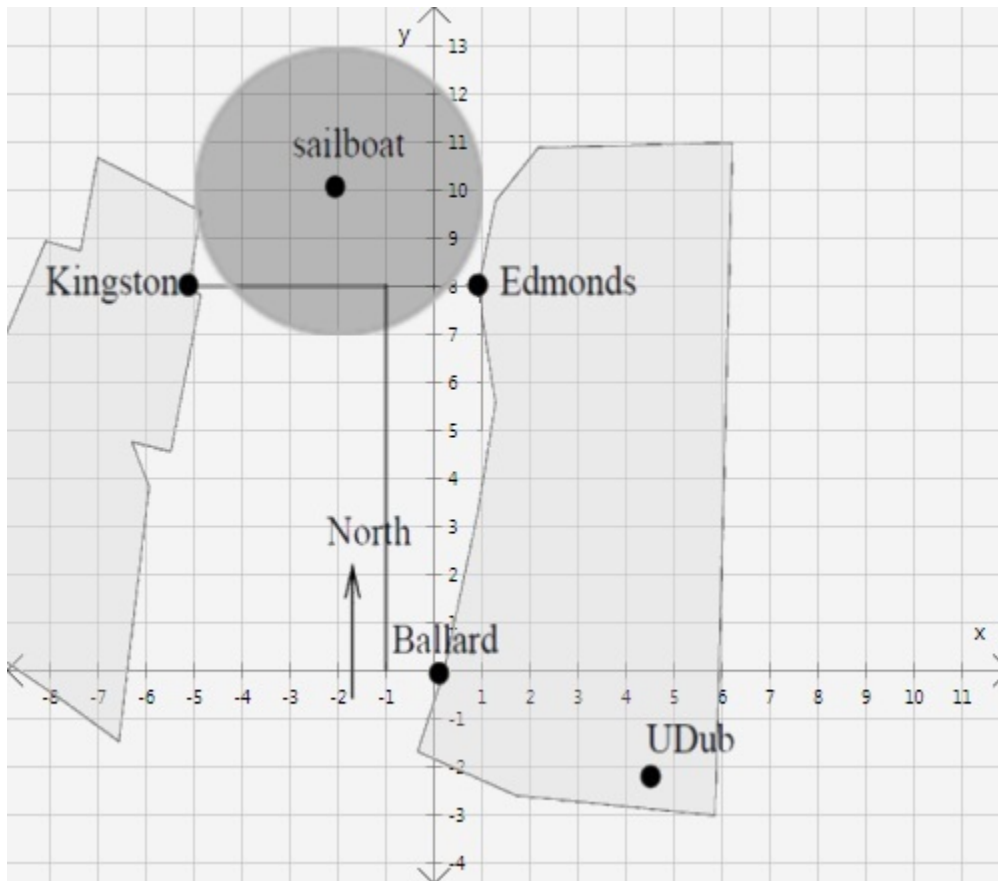

Since Ballard is at the origin  $(0, 0)$ , Edmonds must be at  $(1, 8)$  and Kingston at  $(-5, 8)$ . Therefore, Eric's sailboat is at  $(-2, 10)$ .

(a) Heading east from Kingston to Edmonds, the ferry's movement corresponds to the line  $y = 8$ . Since it travels for 20 minutes at 12 mph, it travels 4 miles, turning south at  $(-1, 8)$ . The equation for the second line is  $x = -1$ .

(b) The boundary of the sailboat's radar zone can be described as  $(x + 2)^2 + (y - 10)^2 = 3^2$ ; the interior of this zone is  $(x + 2)^2 + (y - 10)^2 < 3^2$  and the exterior of this zone is  $(x + 2)^2 + (y - 10)^2 > 3^2$ .

(c) To find when the ferry enters the radar zone, we are looking for the intersection of the line  $y = 8$  and the boundary of the sailboat's radar zone. Substituting  $y = 8$  into the equation of the

circle, we have  $(x + 2)^2 + (-2)^2 = 9$ , and  $(x + 2)^2 = 5$ . Therefore,  $x + 2 = \pm\sqrt{5}$  and  $x = -2 \pm \sqrt{5}$ . These two values are approximately 0.24 and -4.24. The ferry enters at  $x = -4.24$  ( $x = 0.24$  is where it would have exited the radar zone, had it continued on toward Edmonds). Since it started at Kingston, which has an x-coordinate of -5, it has traveled about 0.76 miles. This journey – at 12 mph – requires about 0.0633 hours, or about 3.8 minutes.

(d) The ferry exits the radar zone at the intersection of the line  $x = -1$  with the circle.

Substituting, we have  $1^2 + (y - 10)^2 = 9$ ,  $(y - 10)^2 = 8$ , and  $y - 10 = \pm\sqrt{8}$ .  $y = 10 + \sqrt{8} \approx 12.83$  is the northern boundary of the intersection; we are instead interested in the southern boundary, which is at  $y = 10 - \sqrt{8} \approx 7.17$ . The ferry exits the radar zone at  $(-1, 7.17)$ . It has traveled 4 miles from Kingston to the point at which it turned, plus an additional 0.83 miles heading south, for a total of 4.83 miles. At 12 mph, this took about 0.4025 hours, or 24.2 minutes.

(e) The ferry was inside the radar zone for all 24.2 minutes except the first 3.8 minutes (see part (c)). Thus, it was inside the radar zone for 20.4 minutes.

23. (a) The ditch is 20 feet high, and the water rises one foot (12 inches) in 6 minutes, so it will take 120 minutes (or two hours) to fill the ditch.

(b) Place the origin of a Cartesian coordinate plane at the bottom-center of the ditch. The four circles, from left to right, then have centers at  $(-40, 10)$ ,  $(-20, 10)$ ,  $(20, 10)$  and  $(40, 10)$  respectively:

$$(x + 40)^2 + (y - 10)^2 = 100$$

$$(x + 20)^2 + (y - 10)^2 = 100$$

$$(x - 20)^2 + (y - 10)^2 = 100$$

$$(x - 40)^2 + (y - 10)^2 = 100$$

Solving the first equation for  $y$ , we get:

$$(y - 10)^2 = 100 - (x + 40)^2$$

$$y - 10 = \pm\sqrt{100 - (x + 40)^2}$$

$$y = 10 \pm \sqrt{100 - (x + 40)^2}$$

Since we are only concerned with the upper-half of this circle (actually, only the upper-right fourth of it), we can choose:

$$y = 10 + \sqrt{100 - (x + 40)^2}$$

A similar analysis will give us the desired parts of the other three circles. Notice that for the second and third circles, we need to choose the  $-$  part of the  $\pm$  to describe (part of) the bottom half of the circle.

The remaining parts of the piecewise function are constant equations:

$$y = \begin{cases} 20 & x < -40 \\ 10 + \sqrt{100 - (x + 40)^2} & -40 \leq x < -30 \\ 10 - \sqrt{100 - (x + 20)^2} & -30 \leq x < -20 \\ 0 & -20 \leq x < 20 \\ 10 - \sqrt{100 - (x - 20)^2} & 20 \leq x < 30 \\ 10 + \sqrt{100 - (x - 40)^2} & 30 \leq x < 40 \\ 20 & x \geq 40 \end{cases}$$

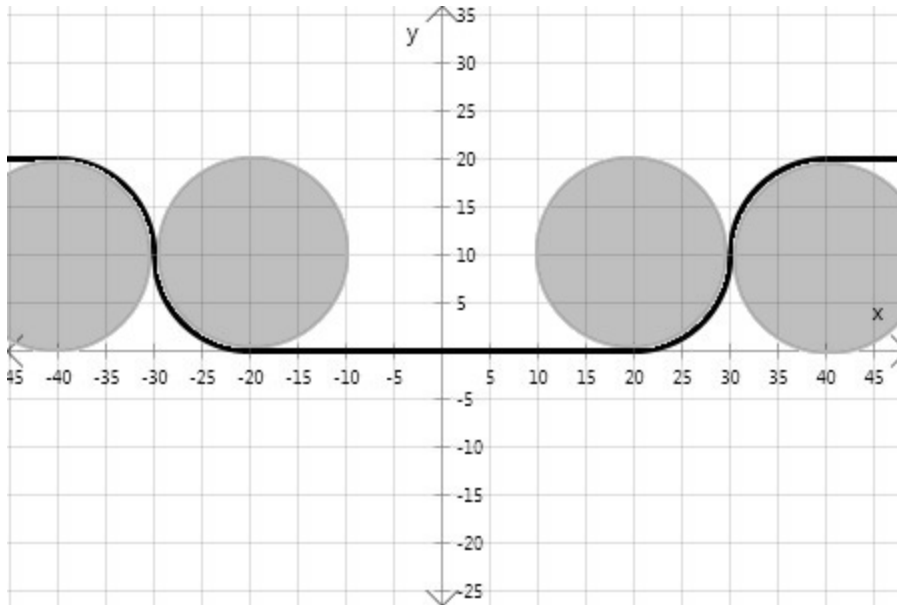

(c) At 1 hour and 18 minutes (78 minutes), the ditch will have 156 inches of water, or 13 feet. We need to find the x-coordinates that give  $usy = 13$ . Looking at the graph, it is clear that this occurs in the first and fourth circles. For the first circle, we return to the original equation:

$$(x + 40)^2 + (13 - 10)^2 = 100$$

$$(x + 40)^2 = 91$$

$$x = -40 \pm \sqrt{91}$$

We choose  $x = -40 + \sqrt{91} \approx -30.46$  since  $x$  must be in the domain of the second piece of the piecewise function, which represents the upper-right part of the first circle. For the fourth (rightmost) circle, we have:

$$(x - 40)^2 + (13 - 10)^2 = 100$$

$$(x - 40)^2 = 91$$

$$x = 40 \pm \sqrt{91}$$

We choose  $x = 40 - \sqrt{91} \approx 30.46$  to ensure that  $x$  is in the domain of the sixth piece of the piecewise function, which represents the upper-left part of the fourth circle.

The width of the ditch is therefore  $30.46 - (-30.46) = 60.92$  feet. Notice the symmetry in the  $x$ -coordinates we found.

(d) Since our piecewise function is symmetrical across the  $y$ -axis, when the filled portion of the ditch is 42 feet wide, we can calculate the water height using either  $x = -21$  or  $x = 21$ . Using  $x = 21$ , we must choose the fifth piece of the piecewise function:

$$y = 10 - \sqrt{100 - (21 - 20)^2} = 10 - \sqrt{99} \approx 0.05$$

The height is 0.05 feet. At 6 minutes per foot, this will happen after 0.3 minutes, or 18 seconds.

(Notice that we could have chosen  $x = -21$ ; then we would have used the third piece of the function and calculated:

$$10 - \sqrt{100 - (-21 + 20)^2} = 10 - \sqrt{99} \approx 0.05.)$$

When the width of the filled portion is 50 feet, we choose either  $x = -25$  or  $x = 25$ . Choosing  $x = 25$  requires us to use the fifth piece of the piecewise function:

$$10 - \sqrt{100 - (25 - 20)^2} = 10 - \sqrt{75} \approx 1.34$$

The height of the water is then 1.34 feet. At 6 minutes per foot, this will happen after 8.04 minutes.

Finally, when the width of the filled portion is 73 feet, we choose  $x = 36.5$ . This requires us to use the sixth piece of the piecewise function:

$$10 + \sqrt{100 - (36.5 - 40)^2} = 10 + \sqrt{87.75} \approx 19.37$$

The height of the water is 19.37 feet after about 116.2 minutes have elapsed. At 19.37 feet, the ditch is nearly full; the answer to part a) told us that it is completely full after 120 minutes.

## 5.2 Solutions to Exercises

1.

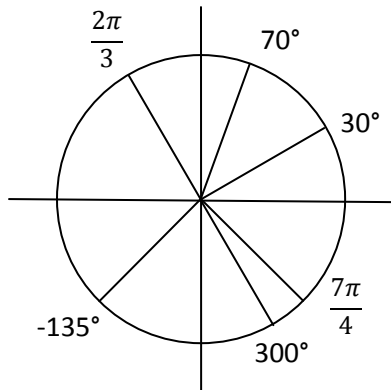

3.  $(180^\circ)\left(\frac{\pi}{180^\circ}\right) = \pi$

5.  $\left(\frac{5\pi}{6}\right)\left(\frac{180^\circ}{\pi}\right) = 150^\circ$

7.  $685^\circ - 360^\circ = 325^\circ$

9.  $-1746^\circ + 5(360^\circ) = 54^\circ$

11.  $\left(\frac{26\pi}{9} - 2\pi\right) = \left(\frac{26\pi}{9} - \frac{18\pi}{9}\right) = \frac{8\pi}{9}$

13.  $\left(\frac{-3\pi}{2} + 2\pi\right) = \left(\frac{-3\pi}{2} + \frac{4\pi}{2}\right) = \frac{\pi}{2}$

15.  $r = 7 \text{ m}, \theta = 5 \text{ rad}, s = \theta r \rightarrow s = (7 \text{ m})(5) = 35 \text{ m}$

17.  $r = 12 \text{ cm}, \theta = 120^\circ = \frac{2\pi}{3}, s = \theta r \rightarrow s = (12 \text{ cm})\left(\frac{2\pi}{3}\right) = 8\pi \text{ cm}$



19.  $r = 3960$  miles,  $\theta = 5$  minutes  $= \frac{5}{60}^\circ = \frac{\pi}{2160}$ ,  $s = r\theta \rightarrow s = (3960 \text{ miles}) \left( \frac{\pi}{2160} \right) = \frac{11\pi}{6}$  miles

21.  $r = 6$  ft,  $s = 3$  ft,  $s = r\theta \rightarrow \theta = s/r$

Plugging in we have  $\theta = (3 \text{ ft})/(6 \text{ ft}) = 1/2$  rad.

$$(1/2)((180^\circ)/(\pi)) = 90/\pi^\circ \approx 28.6479^\circ$$

23.  $\theta = 45^\circ = \frac{\pi}{4}$  radians,  $r = 6$  cm

$$A = \frac{1}{2}\theta r^2; \text{ we have } A = \frac{1}{2}\left(\frac{\pi}{4}\right)(6 \text{ cm})^2 = \frac{9\pi}{2} \text{ cm}^2$$

25.  $D = 32$  in, speed  $= 60$  mi/hr  $= 1$  mi/min  $= 63360$  in/min  $= v$ ,  $C = \pi D$ ,  $v = \frac{s}{t}$ ,  $s = \theta r$ ,  $v =$

$\frac{\theta r}{t}$ ,  $\frac{v}{t} = \frac{\theta}{t} = \omega$ . So  $\omega = \frac{63360 \frac{\text{in}}{\text{min}}}{16 \text{ in}} = 3960$  rad/min. Dividing by  $2\pi$  will yield 630.25 rotations per minute.

27.  $r = 8$  in.,  $\omega = 15^\circ/\text{sec} = \frac{\pi}{12}$  rad/sec,  $v = \omega r$ ,  $v = \left(\frac{\pi}{12}\right)(8 \text{ in}) = \frac{2.094 \text{ in}}{\text{sec}}$ . To find RPM we must multiply by a factor of 60 to convert seconds to minutes, and then divide by  $2\pi$  to get, RPM=2.5.

29.  $d = 120$ mm for the outer edge.  $\omega = 200$ rpm; multiplying by  $2\pi$  rad/rev, we get  $\omega = 400\pi$  rad/min.  $v = r\omega$ , and  $r = 60$  mm, so  $v = (60 \text{ mm}) \left( 400\pi \frac{\text{rad}}{\text{min}} \right) = 75,398.22$ mm/min. Dividing by a factor of 60 to convert minutes into seconds and then a factor of 1,000 to convert and mm into meters, this gives  $v = 1.257$  m/sec.

31.  $r = 3960$ miles. One full rotation takes 24 hours, so  $\omega = \frac{\theta}{t} = \frac{2\pi}{24 \text{ hours}} = \frac{\pi}{12}$ rad/hour. To find the linear speed,  $v = r\omega$ , so  $v = (3960 \text{ miles}) \left( \frac{\pi}{12} \frac{\text{rad}}{\text{hour}} \right) = 1036.73$ miles/hour .

### 5.3 Solutions to Exercises

1. a. Recall that the sine is negative in quadrants 3 and 4, while the cosine is negative in quadrants 2 and 3; they are both negative only in quadrant III
- b. Similarly, the sine is positive in quadrants 1 and 2, and the cosine is negative in quadrants 2 and 3, so only quadrant II satisfies both conditions.

3. Because sine is the x-coordinate divided by the radius, we have  $\sin \theta = \left(\frac{3}{5}\right)/1$  or just  $\frac{3}{5}$ . If we use the trig version of the Pythagorean theorem,  $\sin^2 \theta + \cos^2 \theta = 1$ , with  $\sin \theta = \frac{3}{5}$ , we get  $\frac{9}{25} + \cos^2 \theta = 1$ , so  $\cos^2 \theta = \frac{25}{25} - \frac{9}{25}$  or  $\cos^2 \theta = \frac{16}{25}$ ; then  $\cos \theta = \pm \frac{4}{5}$ . Since we are in quadrant 2, we know that  $\cos \theta$  is negative, so the result is  $-\frac{4}{5}$ .

5. If  $\cos \theta = \frac{1}{7}$ , then from  $\sin^2 \theta + \cos^2 \theta = 1$  we have  $\sin^2 \theta + \frac{1}{49} = 1$ , or  $\sin^2 \theta = \frac{49}{49} - \frac{1}{49} = \frac{48}{49}$ . Then  $\sin \theta = \pm \frac{\sqrt{48}}{7}$ ; simplifying gives  $\pm \frac{4\sqrt{3}}{7}$  and we know that in the 4<sup>th</sup> quadrant  $\sin \theta$  is negative, so our final answer is  $-\frac{4\sqrt{3}}{7}$ .

7. If  $\sin \theta = \frac{3}{8}$  and  $\sin^2 \theta + \cos^2 \theta = 1$ , then  $\frac{9}{64} + \cos^2 \theta = 1$ , so  $\cos^2 \theta = \frac{55}{64}$  and  $\cos \theta = \frac{\pm\sqrt{55}}{8}$ ; in the second quadrant we know that the cosine is negative so the answer is  $-\frac{\sqrt{55}}{8}$ .

9. a. 225 is 45 more than 180, so our reference angle is  $45^\circ$ .  $225^\circ$  lies in quadrant III, where sine is negative and cosine is negative, then  $\sin(225^\circ) = -\sin(45^\circ) = -\frac{\sqrt{2}}{2}$ , and  $\cos(225^\circ) = -\cos(45^\circ) = -\frac{\sqrt{2}}{2}$ .

b. 300 is 60 less than 360 (which is equivalent to zero degrees), so our reference angle is  $60^\circ$ . 300 lies in quadrant IV, where sine is negative and cosine is positive.  $\sin(300^\circ) = -\sin(60^\circ) = -\frac{\sqrt{3}}{2}$ ;  $\cos(300^\circ) = \cos(60^\circ) = \frac{1}{2}$ .

c. 135 is 45 less than 180, so our reference angle is  $45^\circ$ .  $135^\circ$  lies in quadrant II, where sine is positive and cosine is negative.  $\sin(135^\circ) = \sin(45^\circ) = \frac{\sqrt{2}}{2}$ ;  $\cos(135^\circ) = -\cos(45^\circ) = -\frac{\sqrt{2}}{2}$ .

d. 210 is 30 more than 180, so our reference angle is  $30^\circ$ .  $210^\circ$  lies in quadrant III, where sine and cosine are both negative.  $\sin(210^\circ) = -\sin(30^\circ) = -\frac{1}{2}$ ;  $\cos(210^\circ) = -\cos(30^\circ) = -\frac{\sqrt{3}}{2}$ .

11. a.  $\frac{5\pi}{4}$  is  $\pi + \frac{\pi}{4}$  so our reference is  $\frac{\pi}{4}$ .  $\frac{5\pi}{4}$  lies in quadrant III, where sine and cosine are both negative.  $\sin\left(\frac{5\pi}{4}\right) = -\sin\left(\frac{\pi}{4}\right) = -\frac{\sqrt{2}}{2}$ ;  $\cos\left(\frac{5\pi}{4}\right) = -\cos\left(\frac{\pi}{4}\right) = -\frac{\sqrt{2}}{2}$ .

b.  $\frac{7\pi}{6}$  is  $\pi + \frac{\pi}{6}$  so our reference is  $\frac{\pi}{6}$ .  $\frac{7\pi}{6}$  is in quadrant III where sine and cosine are both negative.  $\sin\left(\frac{7\pi}{6}\right) = -\sin\left(\frac{\pi}{6}\right) = -\frac{1}{2}$ ;  $\cos\left(\frac{7\pi}{6}\right) = -\cos\left(\frac{\pi}{6}\right) = -\frac{\sqrt{3}}{2}$ .

c.  $\frac{5\pi}{3}$  is  $2\pi - \frac{\pi}{3}$  so the reference angle is  $\frac{\pi}{3}$ , in quadrant IV where sine is negative and cosine is positive.  $\sin\left(\frac{5\pi}{3}\right) = -\sin\left(\frac{\pi}{3}\right) = -\frac{\sqrt{3}}{2}$ ;  $\cos\left(\frac{5\pi}{3}\right) = \cos\left(\frac{\pi}{3}\right) = \frac{1}{2}$ .

d.  $\frac{3\pi}{4}$  is  $\pi - \frac{\pi}{4}$ ; our reference is  $\frac{\pi}{4}$ , in quadrant II where sine is positive and cosine is negative.  $\sin\left(\frac{3\pi}{4}\right) = \sin\left(\frac{\pi}{4}\right) = \frac{\sqrt{2}}{2}$ ;  $\cos\left(\frac{3\pi}{4}\right) = -\cos\left(\frac{\pi}{4}\right) = -\frac{\sqrt{2}}{2}$ .

13. a.  $-\frac{3\pi}{4}$  lies in quadrant 3, and its reference angle is  $\frac{\pi}{4}$ , so  $\sin\left(-\frac{3\pi}{4}\right) = -\sin\left(\frac{\pi}{4}\right) = -\frac{\sqrt{2}}{2}$ ;  $\cos\left(-\frac{3\pi}{4}\right) = -\cos\left(\frac{\pi}{4}\right) = -\frac{\sqrt{2}}{2}$ .

b.  $\frac{23\pi}{6} = \frac{12\pi}{6} + \frac{11\pi}{6} = 2\pi + \frac{11\pi}{6}$ ; we can drop the  $2\pi$ , and notice that  $\frac{11\pi}{6} = 2\pi - \frac{\pi}{6}$  so our reference angle is  $\frac{\pi}{6}$ , and  $\frac{11\pi}{6}$  is in quadrant 4 where sine is negative and cosine is positive. Then  $\sin\left(\frac{23\pi}{6}\right) = -\sin\left(\frac{\pi}{6}\right) = -\frac{1}{2}$  and  $\cos\left(\frac{23\pi}{6}\right) = \cos\left(\frac{\pi}{6}\right) = \frac{\sqrt{3}}{2}$ .

c. For  $-\frac{\pi}{2}$ , if we draw a picture we see that the ray points straight down, so  $y$  is  $-1$  and  $x$  is  $0$ ;  $\sin\left(-\frac{\pi}{2}\right) = \frac{y}{1} = -1$ ;  $\cos\left(-\frac{\pi}{2}\right) = \frac{x}{1} = 0$ .

d.  $5\pi = 4\pi + \pi = (2 * 2\pi) + \pi$ ; remember that we can drop multiples of  $2\pi$  so this is the same as just  $\pi$ .  $\sin(5\pi) = \sin(\pi) = 0$ ;  $\cos(5\pi) = \cos(\pi) = -1$ .

15. a.  $\frac{\pi}{3}$  is in quadrant 1, where sine is positive; if we choose an angle with the same reference angle as  $\frac{\pi}{3}$  but in quadrant 2, where sine is also positive, then it will have the same sine value.

$$\frac{2\pi}{3} = \pi - \frac{\pi}{3}, \text{ so } \frac{2\pi}{3} \text{ has the same reference angle and sine as } \frac{\pi}{3}.$$

b. Similarly to problem a. above,  $100^\circ = 180^\circ - 80^\circ$ , so both  $80^\circ$  and  $100^\circ$  have the same reference angle ( $80^\circ$ ), and both are in quadrants where the sine is positive, so  $100^\circ$  has the same sine as  $80^\circ$ .

c.  $140^\circ$  is  $40^\circ$  less than  $180^\circ$ , so its reference angle is  $40^\circ$ . It is in quadrant 2, where the sine is positive; the sine is also positive in quadrant 1, so  $40^\circ$  has the same sine value and sign as  $140^\circ$ .

d.  $\frac{4\pi}{3}$  is  $\frac{\pi}{3}$  more than  $\pi$ , so its reference angle is  $\frac{\pi}{3}$ . It is in quadrant 3, where the sine is negative.

Looking for an angle with the same reference angle of  $\frac{\pi}{3}$  in a different quadrant where the sine is also negative, we can choose quadrant 4 and  $\frac{5\pi}{3}$  which is  $2\pi - \frac{\pi}{3}$ .

e.  $305^\circ$  is  $55^\circ$  less than  $360^\circ$ , so its reference angle is  $55^\circ$ . It is in quadrant 4, where the sine is negative. An angle with the same reference angle of  $55^\circ$  in quadrant 3 where the sine is also negative would be  $180^\circ + 55^\circ = 235^\circ$ .

17. a.  $\frac{\pi}{3}$  has reference angle  $\frac{\pi}{3}$  and is in quadrant 1, where the cosine is positive. The cosine is also positive in quadrant 4, so we can choose  $2\pi - \frac{\pi}{3} = \frac{6\pi}{3} - \frac{\pi}{3} = \frac{5\pi}{3}$ .

b.  $80^\circ$  is in quadrant 1, where the cosine is positive, and has reference angle  $80^\circ$ . We can choose quadrant 4, where the cosine is also positive, and where a reference angle of  $80^\circ$  gives  $360^\circ - 80^\circ = 280^\circ$ .

c.  $140^\circ$  is in quadrant 2, where the cosine is negative, and has reference angle  $180^\circ - 140^\circ = 40^\circ$ . We know that the cosine is also negative in quadrant 3, where a reference angle of  $40^\circ$  gives  $180^\circ + 40^\circ = 220^\circ$ .

d.  $\frac{4\pi}{3}$  is  $\pi + \frac{\pi}{3}$ , so it is in quadrant 3 with reference angle  $\frac{\pi}{3}$ . In this quadrant the cosine is negative; we know that the cosine is also negative in quadrant 2, where a reference angle of  $\frac{\pi}{3}$  gives

$$\pi - \frac{\pi}{3} = \frac{3\pi}{3} - \frac{\pi}{3} = \frac{2\pi}{3}.$$

e.  $305^\circ = 360^\circ - 55^\circ$ , so it is in quadrant 4 with reference angle  $55^\circ$ . In this quadrant the cosine is positive, as it also is in quadrant 1, so we can just choose  $55^\circ$  as our result.

19. Using a calculator,  $\cos(220^\circ) \approx -0.76604$  and  $\sin(220^\circ) \approx -0.64279$ . Plugging in these values for cosine and sine along with  $r = 15$  into the formulas  $\cos(\theta) = \frac{x}{r}$  and  $\sin(\theta) = \frac{y}{r}$ , we get the equations  $-0.76604 \approx \frac{x}{15}$  and  $-0.64279 \approx \frac{y}{15}$ . Solving gives us the point  $(-11.49067, -9.64181)$ .

21. a. First let's find the radius of the circular track. If Marla takes 46 seconds at 3 meters/second to go around the circumference of the track, then the circumference is  $46 \cdot 3 = 138$  meters. From the formula for the circumference of a circle, we have  $138 = 2\pi r$ , so  $r = 138/2\pi \approx 21.963$  meters.

Next, let's find the angle between north (up) and her starting point; if she runs for 12 seconds, she covers  $12/46$  of the complete circle, which is  $12/46$  of  $360^\circ$  or about  $0.261 \cdot 360^\circ \approx 93.913^\circ$ . The northernmost point is at  $90^\circ$  (since we measure angles from the positive  $x$ -axis) so her starting point is at an angle of  $90^\circ + 93.913^\circ = 183.913^\circ$ . This is in quadrant 3; we can get her  $x$  and  $y$  coordinates using the reference angle of  $3.913^\circ$ :  $x = -r\cos(3.913^\circ)$  and  $y = -r\sin(3.913^\circ)$ . We get  $(-21.9118003151, -1.4987914972)$ .

b. Now let's find how many degrees she covers in one second of running; this is just  $1/46$  of  $360^\circ$  or  $7.826^\circ/\text{sec}$ . So, in 10 seconds she covers  $78.26^\circ$  from her starting angle of  $183.913^\circ$ . She's running clockwise, but we measure the angle counterclockwise, so we subtract to find that after 10 seconds she is at  $(183.913^\circ - 78.26^\circ) = 105.653^\circ$ . In quadrant 2, the reference angle is  $180^\circ - 105.653^\circ = 74.347^\circ$ . As before, we can find her coordinates from  $x = -r\cos(74.347^\circ)$  and  $y = r\sin(74.347^\circ)$ . We get  $(-5.92585140281, 21.1484669457)$ .

c. When Marla has been running for 901.3 seconds, she has gone around the track several times; each circuit of 46 seconds brings her back to the same starting point, so we divide 901.3 by 46 to get 19.5935 circuits, of which we only care about the last 0.5935 circuit;  $0.5935 \cdot 360^\circ = 213.652^\circ$  measured clockwise from her starting point of  $183.913^\circ$ , or  $183.913^\circ - 213.652^\circ = -29.739^\circ$ . We can take this as a reference angle in quadrant 4, so her coordinates are  $x = r\cos(29.739^\circ)$  and  $y = -r\sin(29.739^\circ)$ . We get  $(19.0703425544, -10.8947420281)$ .

## 5.4 Solutions to Exercises

$$1. \sec\left(\frac{\pi}{4}\right) = \frac{1}{\cos\left(\frac{\pi}{4}\right)} = \frac{1}{\frac{\sqrt{2}}{2}} = \frac{2}{\sqrt{2}} = \sqrt{2}; \csc\left(\frac{\pi}{4}\right) = \frac{1}{\sin\left(\frac{\pi}{4}\right)} = \frac{1}{\frac{\sqrt{2}}{2}} = \frac{2}{\sqrt{2}} = \sqrt{2}; \tan\left(\frac{\pi}{4}\right) = \frac{\sin\left(\frac{\pi}{4}\right)}{\cos\left(\frac{\pi}{4}\right)} = \frac{\frac{\sqrt{2}}{2}}{\frac{\sqrt{2}}{2}} =$$

$$1; \cot\left(\frac{\pi}{4}\right) = \frac{1}{\tan\left(\frac{\pi}{4}\right)} = 1$$

$$3. \sec\left(\frac{5\pi}{6}\right) = \frac{1}{\cos\left(\frac{5\pi}{6}\right)} = \frac{1}{-\frac{\sqrt{3}}{2}} = -\frac{2}{\sqrt{3}} = -\frac{2\sqrt{3}}{3}; \csc\left(\frac{5\pi}{6}\right) = \frac{1}{\sin\left(\frac{5\pi}{6}\right)} = \frac{1}{\frac{1}{2}} = 2; \tan\left(\frac{5\pi}{6}\right) = \frac{\sin\left(\frac{5\pi}{6}\right)}{\cos\left(\frac{5\pi}{6}\right)} =$$

$$\frac{\frac{1}{2}}{-\frac{\sqrt{3}}{2}} = -\frac{\sqrt{3}}{3}; \cot\left(\frac{5\pi}{6}\right) = \frac{1}{\tan\left(\frac{5\pi}{6}\right)} = \frac{1}{-\frac{\sqrt{3}}{3}} = -\sqrt{3}$$

$$5. \sec\left(\frac{2\pi}{3}\right) = \frac{1}{\cos\left(\frac{2\pi}{3}\right)} = \frac{1}{-\frac{1}{2}} = -2; \csc\left(\frac{2\pi}{3}\right) = \frac{1}{\sin\left(\frac{2\pi}{3}\right)} = \frac{1}{\frac{\sqrt{3}}{2}} = \frac{2\sqrt{3}}{3}; \tan\left(\frac{2\pi}{3}\right) = \frac{\sin\left(\frac{2\pi}{3}\right)}{\cos\left(\frac{2\pi}{3}\right)} = \frac{\frac{\sqrt{3}}{2}}{-\frac{1}{2}} =$$

$$-\sqrt{3}; \cot\left(\frac{2\pi}{3}\right) = \frac{1}{\tan\left(\frac{2\pi}{3}\right)} = \frac{1}{-\sqrt{3}} = -\frac{\sqrt{3}}{3}$$

$$7. \sec(135^\circ) = \frac{1}{\cos(135^\circ)} = \frac{1}{-\frac{\sqrt{2}}{2}} = -\sqrt{2}; \csc(210^\circ) = \frac{1}{\sin(210^\circ)} = \frac{1}{-\frac{1}{2}} = -2; \tan(60^\circ) =$$

$$\frac{\sin(60^\circ)}{\cos(60^\circ)} = \frac{\frac{\sqrt{3}}{2}}{\frac{1}{2}} = \sqrt{3}; \cot(225^\circ) = \frac{1}{\tan(225^\circ)} = \frac{1}{1} = 1$$

9. Because  $\theta$  is in quadrant II, we know  $\cos(\theta) < 0$ ,  $\sec(\theta) = \frac{1}{\cos(\theta)} < 0$ ;  $\sin(\theta) > 0$ ,  $\csc(\theta) =$

$$\frac{1}{\sin(\theta)} > 0; \tan(\theta) = \frac{\sin(\theta)}{\cos(\theta)} < 0, \cot(\theta) = \frac{1}{\tan(\theta)} < 0.$$

$$\text{Then: } \cos(\theta) = -\sqrt{1 - \sin^2(\theta)} = -\sqrt{1 - \left(\frac{3}{4}\right)^2} = -\frac{\sqrt{7}}{4}; \sec(\theta) = \frac{1}{\cos(\theta)} = \frac{1}{-\frac{\sqrt{7}}{4}} = -\frac{4\sqrt{7}}{7};$$

$$\csc(\theta) = \frac{1}{\sin(\theta)} = \frac{1}{\frac{3}{4}} = \frac{4}{3}; \tan(\theta) = \frac{\sin(\theta)}{\cos(\theta)} = \frac{\frac{3}{4}}{-\frac{\sqrt{7}}{4}} = \frac{-3\sqrt{7}}{7}; \cot(\theta) = \frac{1}{\tan(\theta)} = \frac{1}{\frac{-3\sqrt{7}}{7}} = \frac{7}{-3\sqrt{7}} = -\frac{\sqrt{7}}{3}$$

11. In quadrant III,  $x < 0, y < 0$ . Imaging a circle with radius  $r$ ,

$$\sin(\theta) = \frac{y}{r} < 0, \csc(\theta) = \frac{1}{\sin(\theta)} < 0; \cos(\theta) = \frac{x}{r} < 0, \sec(\theta) = \frac{1}{\cos(\theta)} < 0; \tan(\theta) = \frac{y}{x} >$$

$$0, \cot(\theta) = \frac{1}{\tan(\theta)} > 0.$$

$$\text{Then: } \sin(\theta) = -\sqrt{1 - \cos^2(\theta)} = \frac{-2\sqrt{2}}{3}; \csc(\theta) = \frac{1}{\sin(\theta)} = \frac{3}{-2\sqrt{2}} = -\frac{3\sqrt{2}}{4}; \sec(\theta) = \frac{1}{\cos(\theta)} = -3; \tan(\theta) = \frac{\sin(\theta)}{\cos(\theta)} = 2\sqrt{2}; \cot(\theta) = \frac{1}{\tan(\theta)} = \frac{1}{2\sqrt{2}} = \frac{\sqrt{2}}{4}$$

13.  $0 \leq \theta \leq \frac{\pi}{2}$  means  $\theta$  is in the first quadrant, so  $x > 0, y > 0$ . In a circle with radius  $r$ :  $\sin(\theta) =$

$$\frac{y}{r} > 0, \csc(\theta) = \frac{1}{\sin(\theta)} > 0; \cos(\theta) = \frac{x}{r} > 0, \sec(\theta) = \frac{1}{\cos(\theta)} > 0; \cot(\theta) = \frac{1}{\tan(\theta)} > 0.$$

Since  $\tan(\theta) = \frac{y}{x} = \frac{12}{5}$ , we can use the point  $(5, 12)$ , for which  $r = \sqrt{12^2 + 5^2} = 13$ .

$$\text{Then: } \sin(\theta) = \frac{y}{r} = \frac{12}{13}; \csc(\theta) = \frac{1}{\sin(\theta)} = \frac{13}{12}; \cos(\theta) = \frac{x}{r} = \frac{5}{13}; \sec(\theta) = \frac{1}{\cos(\theta)} = \frac{13}{5}; \cot(\theta) = \frac{1}{\tan(\theta)} = \frac{5}{12}$$

15. a.  $\sin(0.15) = 0.1494; \cos(0.15) = 0.9888; \tan(0.15) = 0.15$

b.  $\sin(4) = -0.7568; \cos(4) = -0.6536; \tan(4) = 1.1578$

c.  $\sin(70^\circ) = 0.9397; \cos(70^\circ) = 0.3420; \tan(70^\circ) = 2.7475$

d.  $\sin(283^\circ) = -0.9744; \cos(283^\circ) = 0.2250; \tan(283^\circ) = -4.3315$

17.  $\csc(t) \tan(t) = \frac{1}{\sin(t)} \cdot \frac{\sin(t)}{\cos(t)} = \frac{1}{\cos(t)} = \sec(t)$

19.  $\frac{\sec(t)}{\csc(t)} = \frac{\frac{1}{\cos(t)}}{\frac{1}{\sin(t)}} = \frac{\sin(t)}{\cos(t)} = \tan(t)$

21.  $\frac{\sec(t) - \cos(t)}{\sin(t)} = \frac{\frac{1}{\cos(t)} - \cos(t)}{\sin(t)} = \frac{1 - \cos^2(t)}{\sin(t) \cos(t)} = \frac{\sin^2(t)}{\sin(t) \cos(t)} = \frac{\sin(t)}{\cos(t)} = \tan(t)$

23.  $\frac{1 + \cot(t)}{1 + \tan(t)} = \frac{1 + \frac{1}{\tan(t)}}{1 + \tan(t)} \cdot \frac{\tan(t)}{\tan(t)} = \frac{\tan(t) + 1}{(1 + \tan(t)) \tan(t)} = \frac{1}{\tan(t)} = \cot(t)$

$$25. \frac{\sin^2(t) + \cos^2(t)}{\cos^2(t)} = \frac{1}{\cos^2(t)} = \sec^2(t)$$

$$27. \frac{\sin^2(\theta)}{1 + \cos(\theta)} = \frac{1 - \cos^2(\theta)}{1 + \cos(\theta)} \text{ by the Pythagorean identity } \sin^2(\theta) + \cos^2(\theta) = 1$$

$$= \frac{(1 + \cos(\theta))(1 - \cos(\theta))}{1 + \cos(\theta)} \text{ by factoring}$$

$$= 1 - \cos(\theta) \text{ by reducing}$$

$$29. \sec(a) - \cos(a) = \frac{1}{\cos(a)} - \cos(a)$$

$$= \frac{1}{\cos(a)} - \frac{\cos^2(a)}{\cos(a)}$$

$$= \frac{\sin^2(a)}{\cos(a)}$$

$$= \sin(a) \cdot \frac{\sin(a)}{\cos(a)}$$

$$= \sin(a) \cdot \tan(a)$$

31. Note that (with this and similar problems) there is more than one possible solution. Here's one:

$$\frac{\csc^2(x) - \sin^2(x)}{\csc(x) + \sin(x)} = \frac{(\csc(x) + \sin(x))(\csc(x) - \sin(x))}{\csc(x) + \sin(x)} \text{ by factoring}$$

$$= \csc(x) - \sin(x) \text{ by reducing}$$

$$= \frac{1}{\sin(x)} - \sin(x)$$

$$= \frac{1}{\sin(x)} - \frac{\sin^2(x)}{\sin(x)}$$

$$= \frac{\cos^2(x)}{\sin(x)}$$

$$= \cos(x) \cdot \frac{\cos(x)}{\sin(x)}$$

$$= \cos(x) \cot(x)$$

$$33. \frac{\csc^2(\alpha) - 1}{\csc^2(\alpha) - \csc(\alpha)} = \frac{(\csc(\alpha) + 1)(\csc(\alpha) - 1)}{\csc(\alpha) \cdot (\csc(\alpha) - 1)}$$

$$= \frac{\csc(\alpha) + 1}{\csc(\alpha)}$$



$$\begin{aligned}
&= \frac{\frac{1}{\sin(\alpha)} + 1}{\frac{1}{\sin(\alpha)}} \text{applying the identity } \csc(\alpha) = \frac{1}{\sin(\alpha)} \\
&= \left( \frac{1}{\sin(\alpha)} + 1 \right) \cdot \frac{\sin(\alpha)}{1} \\
&= \frac{\sin(\alpha)}{\sin(\alpha)} + \frac{\sin(\alpha)}{1} \\
&= 1 + \sin(\alpha)
\end{aligned}$$

35. To get  $\sin(u)$  into the numerator of the left side, we'll multiply the top and bottom by  $1 - \cos(u)$  and use the Pythagorean identity:

$$\begin{aligned}
\frac{1 + \cos(u)}{\sin(u)} \cdot \frac{1 - \cos(u)}{1 - \cos(u)} &= \frac{1 - \cos^2(u)}{\sin(u)(1 - \cos(u))} \\
&= \frac{\sin^2(u)}{\sin(u)(1 - \cos(u))} \\
&= \frac{\sin(u)}{1 - \cos(u)}
\end{aligned}$$

$$\begin{aligned}
37. \frac{\sin^4(\gamma) - \cos^4(\gamma)}{\sin(\gamma) - \cos(\gamma)} &= \frac{(\sin^2(\gamma) + \cos^2(\gamma))(\sin^2(\gamma) - \cos^2(\gamma))}{\sin(\gamma) - \cos(\gamma)} \text{by factoring} \\
&= \frac{1 \cdot (\sin(\gamma) + \cos(\gamma))(\sin(\gamma) - \cos(\gamma))}{\sin(\gamma) - \cos(\gamma)} \text{by applying the Pythagorean identity, and factoring} \\
&= \sin(\gamma) + \cos(\gamma) \text{by reducing}
\end{aligned}$$

## 5.5 Solutions to Exercises

1.

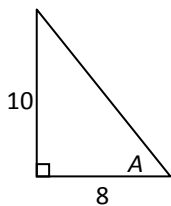

$$\text{hypotenuse}^2 = 10^2 + 8^2 = 164 \Rightarrow \text{hypotenuse} = \sqrt{164} = 2\sqrt{41}$$

$$\text{Therefore, } \sin(A) = \frac{\text{opposite}}{\text{hypotenuse}} = \frac{10}{2\sqrt{41}} = \frac{5}{\sqrt{41}}$$

$$\cos(A) = \frac{\text{adjacent}}{\text{hypotenuse}} = \frac{8}{2\sqrt{41}} = \frac{4}{\sqrt{41}}$$

$$\tan(A) = \frac{\sin(A)}{\cos(A)} = \frac{\frac{5}{\sqrt{41}}}{\frac{4}{\sqrt{41}}} = \frac{5}{4} \text{ or } \tan(A) = \frac{\text{opposite}}{\text{adjacent}} = \frac{10}{8} = \frac{5}{4}$$

$$\sec(A) = \frac{1}{\cos(A)} = \frac{1}{\frac{4}{\sqrt{41}}} = \frac{\sqrt{41}}{4}$$

$$\csc(A) = \frac{1}{\sin(A)} = \frac{1}{\frac{5}{\sqrt{41}}} = \frac{\sqrt{41}}{5}$$

$$\text{and } \cot(A) = \frac{1}{\tan(A)} = \frac{1}{\frac{4}{5}} = \frac{5}{4}$$

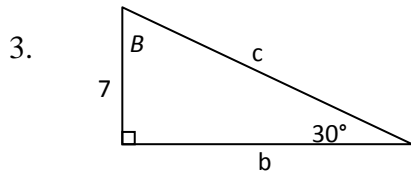

$$\sin(30^\circ) = \frac{7}{c} \Rightarrow c = \frac{7}{\sin(30^\circ)} = \frac{7}{\frac{1}{2}} = 14$$

$$\tan(30^\circ) = \frac{7}{b} \Rightarrow b = \frac{7}{\tan(30^\circ)} = \frac{7}{\frac{1}{\sqrt{3}}} = 7\sqrt{3}$$

$$\text{or } 7^2 + b^2 = c^2 = 14^2 \Rightarrow b^2 = 14^2 - 7^2 = 147 \Rightarrow b = \sqrt{147} = 7\sqrt{3}$$

$$\sin(B) = \frac{b}{c} = \frac{7\sqrt{3}}{14} = \frac{\sqrt{3}}{2} \Rightarrow B = 60^\circ \text{ or } B = 90^\circ - 30^\circ = 60^\circ.$$

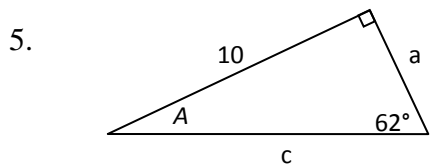

$$\sin(62^\circ) = \frac{10}{c} \Rightarrow c = \frac{10}{\sin(62^\circ)} \approx 11.3257$$

$$\tan(62^\circ) = \frac{10}{a} \Rightarrow a = \frac{10}{\tan(62^\circ)} \approx 5.3171$$

$$A = 90^\circ - 62^\circ = 28^\circ$$

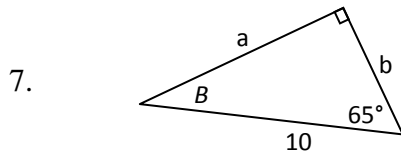

$$B = 90^\circ - 65^\circ = 25^\circ$$

$$\sin(B) = \sin(25^\circ) = \frac{b}{10} \Rightarrow b = 10 \sin(25^\circ) \approx 4.2262$$

$$\cos(B) = \cos(25^\circ) = \frac{a}{10} \Rightarrow a = 10 \cos(25^\circ) \approx 9.0631$$

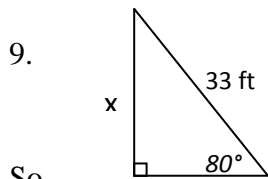

Let x (feet) be the height that the ladder reaches up.

$$\text{Since } \sin(80^\circ) = \frac{x}{33}$$

So the ladder reaches up to  $x = 33 \sin(80^\circ) \approx 32.4987$  ft of the building.

11.

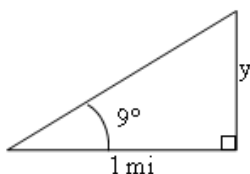

Let  $y$  (miles) be the height of the building. Since  $\tan(9^\circ) = \frac{y}{1} = y$ , the height of the building is  $y = \tan(9^\circ) \text{ mi} \approx 836.26984 \text{ ft}$ .

13.

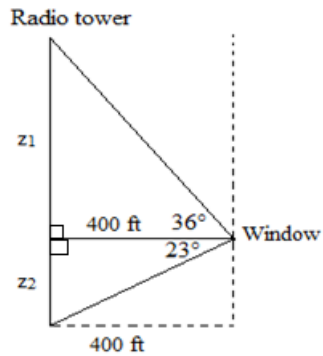

Let  $z_1$  (feet) and  $z_2$  (feet) be the heights of the upper and lower parts of the radio tower. We have

$$\tan(36^\circ) = \frac{z_1}{400} \Rightarrow z_1 = 400 \tan(36^\circ) \text{ ft}$$

$$\tan(23^\circ) = \frac{z_2}{400} \Rightarrow z_2 = 400 \tan(23^\circ) \text{ ft}$$

So the height of the tower is  $z_1 + z_2 = 400 \tan(36^\circ) + 400 \tan(23^\circ) \approx 460.4069 \text{ ft}$ .

15.

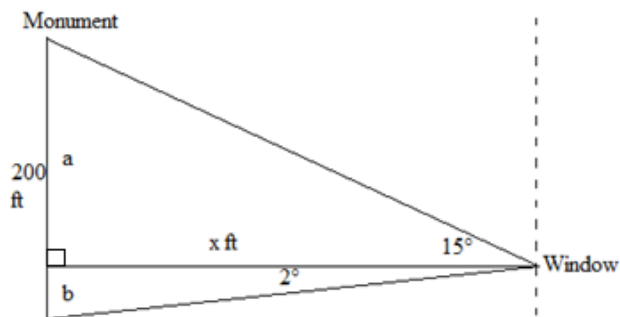

Let  $x$  (feet) be the distance from the person to the monument,  $a$  (feet) and  $b$  (feet) be the heights of the upper and lower parts of the building. We have

$$\tan(15^\circ) = \frac{a}{x} \Rightarrow a = x \tan(15^\circ)$$

and  $\tan(2^\circ) = \frac{b}{x} \Rightarrow b = x \tan(2^\circ)$

Since  $200 = a + b = x \tan (15^\circ) + x \tan (2^\circ) = x [\tan (15^\circ) + \tan (2^\circ)]$

Thus the distance from the person to the monument is  $x = \frac{200}{\tan (15^\circ) + \tan (2^\circ)} \approx 660.3494$  ft.

17.

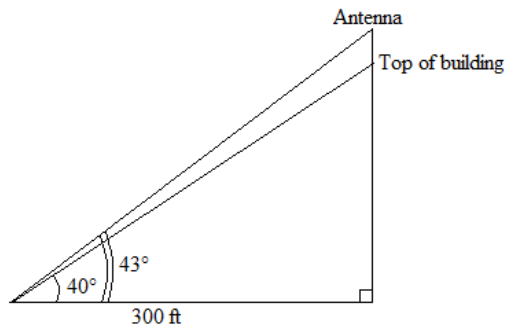

Since  $\tan (40^\circ) = \frac{\text{height from the base to the top of the building}}{300}$ , the height from the base to the top of the building is  $300 \tan (40^\circ)$  ft.

Since  $\tan (43^\circ) = \frac{\text{height from the base to the top of the antenna}}{300}$ , the height from the base to the top of the antenna is  $300 \tan (43^\circ)$  ft.

Therefore, the height of the antenna =  $300 \tan (43^\circ) - 300 \tan (40^\circ) \approx 28.0246$  ft.

19.

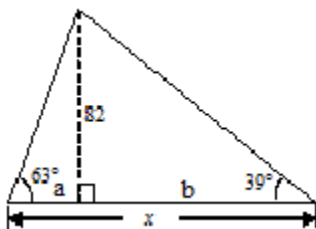

We have  $\tan (63^\circ) = \frac{82}{a} \Rightarrow a = \frac{82}{\tan (63^\circ)}$

$\tan (39^\circ) = \frac{82}{b} \Rightarrow b = \frac{82}{\tan (39^\circ)}$

Therefore  $x = a + b = \frac{82}{\tan (63^\circ)} + \frac{82}{\tan (39^\circ)} \approx 143.04265$ .

21.

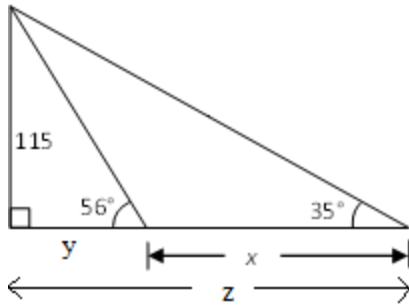

We have  $\tan(35^\circ) = \frac{115}{z} \Rightarrow z = \frac{115}{\tan(35^\circ)}$

$$\tan(56^\circ) = \frac{115}{y} \Rightarrow y = \frac{115}{\tan(56^\circ)}$$

Therefore  $x = z - y = \frac{115}{\tan(35^\circ)} - \frac{115}{\tan(56^\circ)} \approx 86.6685$ .

23.

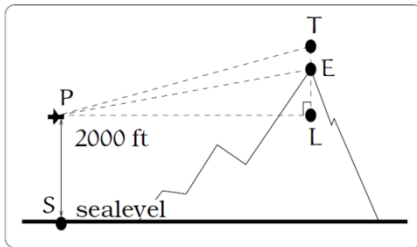

The length of the path that the plane flies from P to T is

$$PT = \left(\frac{100 \text{ mi}}{1 \text{ h}}\right) \left(\frac{1 \text{ h}}{60 \text{ min}}\right) (5 \text{ min}) = \frac{25}{3} \text{ mi} = 44000 \text{ ft}$$

In

$$\triangle PTL, \sin(20^\circ) = \frac{TL}{PT} \Rightarrow TL = PT \sin(20^\circ) = 44000 \sin(20^\circ) \text{ ft}$$

(20°) ft

$$\cos(20^\circ) = \frac{PL}{PT} \Rightarrow PL = PT \cos(20^\circ) = 44000 \cos(20^\circ) \text{ ft}$$

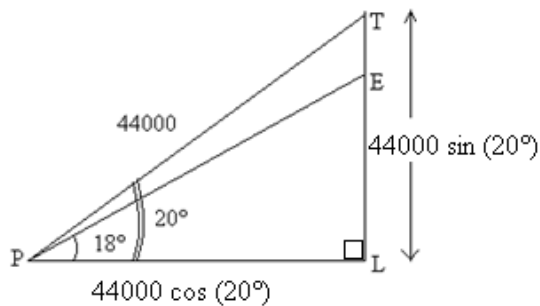

In  $\triangle PEL, \tan(18^\circ) = \frac{EL}{PL} \Rightarrow EL = PL \tan(18^\circ) = 44000 \cos(20^\circ) \tan(18^\circ) \approx 13434.2842 \text{ ft}$

Therefore  $TE = TL - EL = 44000 \sin(20^\circ) - 44000 \cos(20^\circ) \tan(18^\circ)$

$$= 44000 [\sin(20^\circ) - \cos(20^\circ) \tan(18^\circ)] \approx 1614.6021 \text{ ft}$$

So the plane is about 1614.6021 ft above the mountain's top when it passes over. The height of the mountain is the length of  $EL$ , about 13434.2842 ft, plus the distance from sea level to point  $L$ , 2000 ft (the original height of the plane), so the height is about 15434.2842 ft.

25.

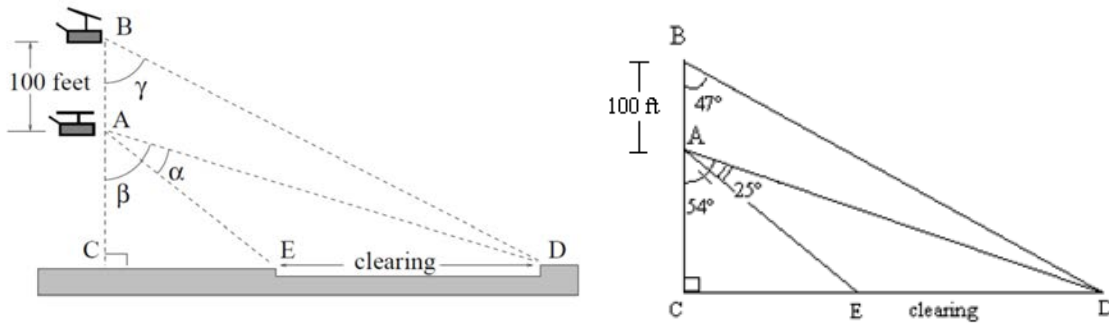

We have:  $\tan(47^\circ) = \frac{CD}{BC} = \frac{CD}{AC+100} \Rightarrow AC + 100 = \frac{CD}{\tan(47^\circ)} \Rightarrow AC = \frac{CD}{\tan(47^\circ)} - 100$

$$\tan(54^\circ) = \frac{CD}{AC} \Rightarrow AC = \frac{CD}{\tan(54^\circ)}$$

Therefore,  $\frac{CD}{\tan(47^\circ)} - 100 = \frac{CD}{\tan(54^\circ)}$

$$\frac{CD}{\tan(47^\circ)} - \frac{CD}{\tan(54^\circ)} = 100$$

$$CD \left( \frac{1}{\tan(47^\circ)} - \frac{1}{\tan(54^\circ)} \right) = 100 \quad \text{or} \quad CD \left( \frac{\tan(54^\circ) - \tan(47^\circ)}{\tan(47^\circ) \tan(54^\circ)} \right) = 100$$

So  $CD = \frac{100 \tan(54^\circ) \tan(47^\circ)}{\tan(54^\circ) - \tan(47^\circ)}$

Moreover,  $\tan(54^\circ - 25^\circ) = \tan(29^\circ) = \frac{CE}{AC} = \frac{CE}{\frac{CD}{\tan(54^\circ)}} = \frac{CE \tan(54^\circ)}{CD}$

$$= \frac{CE \tan(54^\circ)}{\frac{100 \tan(54^\circ) \tan(47^\circ)}{\tan(54^\circ) - \tan(47^\circ)}} = \frac{CE [\tan(54^\circ) - \tan(47^\circ)]}{100 \tan(47^\circ)}$$

$$\Rightarrow CE = \frac{100 \tan(47^\circ) \tan(29^\circ)}{\tan(54^\circ) - \tan(47^\circ)}$$

Thus the width of the clearing should be  $ED = CD - CE = \frac{100 \tan(54^\circ) \tan(47^\circ)}{\tan(54^\circ) - \tan(47^\circ)} - \frac{100 \tan(47^\circ) \tan(29^\circ)}{\tan(54^\circ) - \tan(47^\circ)}$

$$= \frac{100 \tan(47^\circ)}{\tan(54^\circ) - \tan(47^\circ)} [\tan(54^\circ) - \tan(29^\circ)] \approx 290 \text{ ft.}$$

## 6.1 Solutions to Exercises

1. There is a vertical stretch with a factor of 3, and a horizontal reflection.

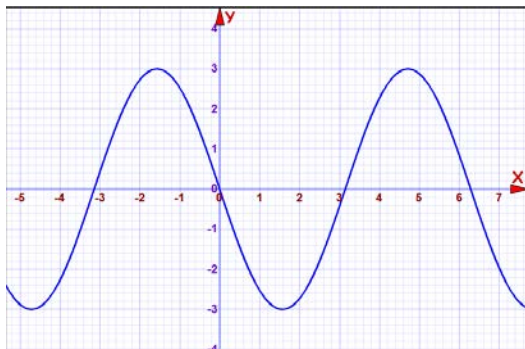

3. There is a vertical stretch with a factor of 2.

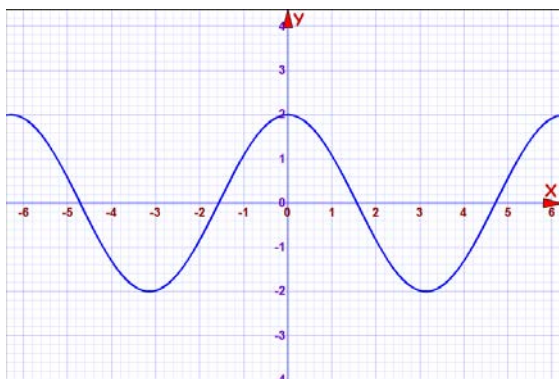

5. Period:  $2$ . Amplitude:  $3$ . Midline:  $y = -4$ .

The function is a sine function, because the midline intersects with the y axis, with the form

$f(x) = A \sin(Bx) + C$ .  $C$  is the midline, and  $A$  is the amplitude.  $B = \frac{2\pi}{\text{Period}} = \frac{2\pi}{2}$ , so  $B$  is  $\pi$ . So, the formula is  $f(x) = 3 \sin(\pi x) - 4$ .

7. Period:  $4\pi$ . Amplitude:  $2$ . Midline:  $y = 1$ .

The function is a cosine function because its maximum intersects with the y axis, which has the

form  $f(x) = A \cos(Bx) + C$ .  $C$  is the midline and  $A$  is the Amplitude.  $B = \frac{2\pi}{\text{Period}}$ , so  $B = \frac{1}{2}$ . The formula is  $f(x) = 2 \cos\left(\frac{x}{2}\right) + 1$ .

9. Period:  $5$ . Amplitude:  $2$ . Midline:  $y = 3$ .

It is also important to note that it has a vertical reflection, which will make  $A$  negative.

This material was created by Shoreline Community College and edited by Rosalie Tepper. This material is licensed under a Creative Commons NonCommercial-ShareAlike license.

The function is a cosine function because its minimum intersects with the  $y$  axis, which has the form  $f(x) = A \cos(Bx) + C$ .  $C$  is the midline and  $A$  is the Amplitude.  $B = \frac{2\pi}{\text{Period}}$ , so  $B = \frac{2\pi}{5}$ . The formula is  $f(x) = -2 \cos\left(\frac{2\pi}{5}x\right) + 3$ .

11. Amplitude: 3. The period is  $\frac{2\pi}{B}$ , where  $B$  is the coefficient in front of  $x$ . Period  $= \frac{\pi}{4}$ .  
Horizontal shift: 4 to the left. Midline:  $y = 5$ .

13. Amplitude: 2. The period is  $\frac{2\pi}{B}$ , where  $B$  is the coefficient in front of  $x$ . Period  $= \frac{2\pi}{3}$ . In order to find the horizontal shift the inside of the sine operator must be factored.  $3x - 21 = 3(x - 7)$ . Horizontal shift: 7 to the right. Midline:  $y = 4$ .

15. Amplitude: 1. The period is  $\frac{2\pi}{B}$ , where  $B$  is the coefficient in front of  $x$ . Period: 12. In order to find the horizontal shift, the inside of the sine operator must be factored.  $\frac{\pi}{6}x + \pi = \frac{\pi}{6}(x + 6)$ . Horizontal shift: 6 to the left. Midline:  $y = -3$ .

17. To find the formula of the function we must find the Amplitude, stretch or shrink factor, horizontal shift, and midline.

The graph oscillates from a minimum of -4 to a maximum of 4, so the midline is at  $y = 0$  because that is halfway between.

The Amplitude is the distance between the midline and the maximum or minimum, so the Amplitude is 4.

The stretch or shrink factor is  $\frac{2\pi}{\text{Period}}$ . The period is 10 which is the distance from one peak to the next peak. So,  $B = \frac{2\pi}{10}$  or  $\frac{\pi}{5}$ .

To find the horizontal shift we must first decide whether to use sine or cosine. If you were to use cosine the horizontal shift would be  $\frac{3}{2}$  to the right. If you were to use sine it would be 1 to the left. Thus the formula could be  $f(x) = 4 \sin\left(\frac{\pi}{5}(x + 1)\right)$  or  $f(x) = 4 \cos\left(\frac{\pi}{5}\left(x - \frac{3}{2}\right)\right)$ .



19. To find the formula of the function we must find the Amplitude, stretch or shrink factor, horizontal shift, and midline.

The graph oscillates from a minimum of -1 to a maximum of 1, so the midline is at  $y = 0$  because that is halfway between.

The Amplitude is the distance between the midline and the maximum or minimum, so the Amplitude is 1.

The stretch or shrink factor is  $\frac{2\pi}{\text{Period}}$ . The period is 10 which is the distance from one peak to the next peak. So,  $B = \frac{2\pi}{10}$  or  $\frac{\pi}{5}$ .

To find the horizontal shift we must first decide whether to use sine or cosine. If you were to use cosine the horizontal shift would be 2 to the left. If you were to use sine it would be  $\frac{1}{2}$  to the right, but the function would need a vertical reflection since the minimum is to the right of the y axis rather than the maximum.

Thus the formula could be  $f(x) = -\sin\left(\frac{\pi}{5}\left(x - \frac{1}{2}\right)\right)$  or  $f(x) = \cos\left(\frac{\pi}{5}(x + 2)\right)$ .

21. To find the formula of the function we must find the Amplitude, stretch or shrink factor, horizontal shift, and midline.

Since the maximum temperature is 57 and the minimum is 43 degrees, the midline is 50 since that is halfway in between.

The amplitude is 7 because that is the difference between the midline and either the max or the min.

Since the temperature at  $t = 0$  is 50 degrees, sine is the best choice because the midline intersects with vertical axis.

The function must have a vertical reflection because the lowest temperature generally happens in the morning rather than in the afternoon. Having a negative sine function will put the minimum in the morning and the maximum in the afternoon.

Our independent variable  $t$  is in hours so the period is 24 because there are 24 hours in the day.

So, our function is  $D(t) = 50 - 7 \sin\left(\frac{2\pi}{24}t\right)$  which is  $D(t) = 50 - 7 \sin\left(\frac{\pi}{12}t\right)$ .

23.a. The period is 10 minutes because that is how long it takes to get from one point on the Ferris wheel to that same point again.

The maximum point on the Ferris wheel is 26 meters, because it is the height of the wheel plus the extra 1 meter that it is off the ground. The minimum point is 1m since the wheel is 1 meter off the ground. The Amplitude is half of the distance between the maximum and the minimum which is 12.5 meters.

The Midline is where the center of the Ferris wheel is which is one meter more than the Amplitude, because the Ferris wheel starts 1 m off the ground. The Midline is  $y = 13.5$  meters.

b. The formula is  $h(t) = -12.5 \cos\left(\frac{2\pi}{10}t\right) + 13.5$ . The function is a negative cosine function because the Ferris wheel starts at the minimum height.

c. Plug 5 minutes in for  $t$  in the height formula:  $h(5) = -12.5 \cos\left(\frac{2\pi}{10} \cdot 5\right) + 13.5 = 26$  meters.

## 6.2 Solutions to Exercises

1. Features of the graph of  $f(x) = \tan(x)$  include:

- The period of the tangent function is  $\pi$ .
- The domain of the tangent function is  $\theta \neq \frac{\pi}{2} + k\pi$ , where  $k$  is an integer.

- The range of the tangent function is all real numbers,  $(-\infty, \infty)$ .

Therefore the matching graph for  $f(x) = \tan(x)$  is II.

3. Features of the graph of  $f(x) = \csc(x)$  include:

- The period of the cosecant function is  $2\pi$ .
- The domain of the cosecant function is  $\theta \neq k\pi$ , where  $k$  is an integer.
- The range of the cosecant function is  $(-\infty, -1] \cup [1, \infty)$ .

Therefore the matching graph for  $f(x) = \csc(x)$  is I.

5. Since the period of a tangent function is  $\pi$ , the period of  $f(x)$  is  $\frac{\pi}{4}$ , and the horizontal shift is 8 units to the right.

7. Since the period of a secant function is  $2\pi$ , the period of  $h(x)$  is  $\frac{2\pi}{4} = \pi$ , and the horizontal shift is 1 unit to the left.

9. Since the period of a cosecant function is  $2\pi$ , the period of  $m(x)$  is  $\frac{2\pi}{3} = \frac{2\pi}{3}$ , and the horizontal shift is 3 units to the left.

11. A graph of  $h(x) = 2 \sec\left(\frac{\pi}{4}(x + 1)\right)$

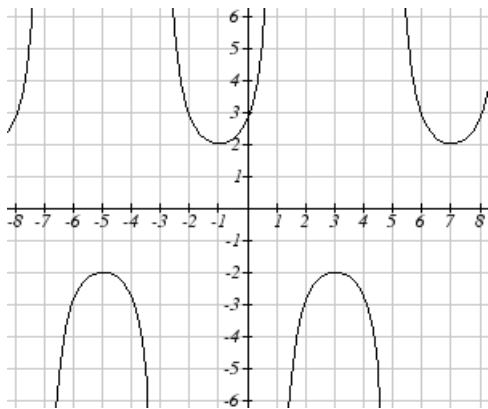

13. A graph of  $m(x) = 6 \csc\left(\frac{\pi}{3}x + \pi\right)$

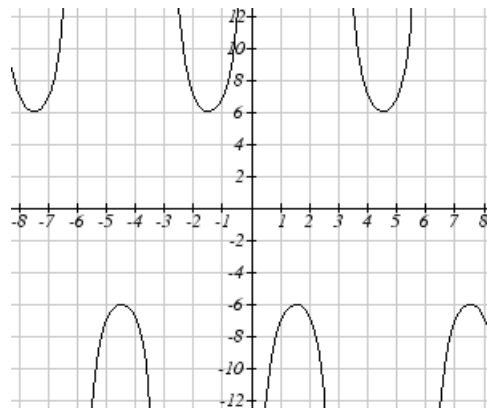

15. To graph  $j(x) = \tan\left(\frac{\pi}{2} x\right)$ :

The period of  $j(x)$  is  $\pi/\frac{\pi}{2} = 2$ , so the horizontal stretch should be 2 units in length. Since the coefficient of  $j(x)$  is 1, there is no vertical stretch.

The period of a tangent function is  $\pi$ , and its domain is  $\theta \neq \frac{\pi}{2} + k\pi$ , where  $k$  is an integer.

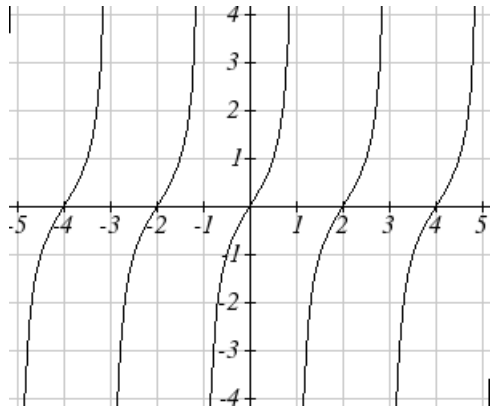

17. The graph of  $f(x)$  has the shape of either a secant or a cosecant function. However, since it has domain of  $x \neq \frac{\pi}{2} + k\pi$  ( $k$  is an integer), it should be the graph of a secant function.

Assume that the function has form of  $f(x) = a \sec(kx) + b$ .

- Because period of the graph is 2, it is compressed by  $\frac{2}{\pi}$  or  $k = \frac{\pi}{2}$ .
- The graph is shifted down by 1 unit, then  $b = -1$ .
- To find  $a$ , use the point  $(0,1)$ . Substitute this into the formula of  $f(x)$ , we have

$$1 = a \sec(0) - 1$$

$$1 = a - 1$$

$$a = 2$$

Thus, a formula of the function graphed above is  $f(x) = 2 \sec\left(\frac{\pi}{2} x\right) - 1$ .

19. The graph of  $h(x)$  has the shape of either a secant or a cosecant function. However, since it has domain of  $x \neq k\pi$  ( $k$  is an integer), it should be the graph of a cosecant function.

Assume that the function has form of  $h(x) = a \csc(kx) + b$ .

- Because period of the graph is 4, it is compressed by  $\frac{4}{\pi}$  or  $k = \frac{\pi}{4}$ .
- The graph is shifted up by 1 unit, then  $b = 1$ .
- To find  $a$ , use the point (2,3). Substitute this into the formula of  $h(x)$ , we have

$$3 = a \csc\left(\frac{\pi}{4} \cdot 2\right) + 1$$

$$3 = a + 1$$

$$a = 2$$

Thus, a formula of the function graphed above is  $h(x) = 2 \csc\left(\frac{\pi}{4}x\right) + 1$ .

$$21. \tan(-x) = -\tan x = -(-1.5) = 1.5$$

$$23. \sec(-x) = -\sec x = -2$$

$$25. \csc(-x) = -\csc x = -(-5) = 5$$

$$27. \cot(-x) \cos(-x) + \sin(-x) = (-\cot x)(\cos x) - \sin x = \left(-\frac{\cos x}{\sin x}\right)(\cos x) - \sin x$$

$$= -\frac{\cos^2 x}{\sin x} - \sin x = \frac{-(\cos^2 x + \sin^2 x)}{\sin x} = -\frac{1}{\sin x} = -\csc x.$$

### 6.3 Solutions to Exercises

1. For  $\sin^{-1}\left(\frac{\sqrt{2}}{2}\right)$ , we are looking for an angle in  $\left[-\frac{\pi}{2}, \frac{\pi}{2}\right]$  with a sine value of  $\frac{\sqrt{2}}{2}$ . The angle that satisfies this is  $\sin^{-1}\left(\frac{\sqrt{2}}{2}\right) = \frac{\pi}{4}$ .

3. For  $\sin^{-1}\left(-\frac{1}{2}\right)$ , we are looking for an angle in  $\left[-\frac{\pi}{2}, \frac{\pi}{2}\right]$  with a sine value of  $-\frac{1}{2}$ . The angle that satisfies this is  $\sin^{-1}\left(-\frac{1}{2}\right) = -\frac{\pi}{6}$ .

5. For  $\cos^{-1}(\frac{1}{2})$ , we are looking for an angle in  $[0,\pi]$  with a cosine value of  $\frac{1}{2}$ . The angle that satisfies this is  $\cos^{-1}(\frac{1}{2}) = \frac{\pi}{3}$ .

7. For  $\cos^{-1}(-\frac{\sqrt{2}}{2})$ , we are looking for an angle in  $[0,\pi]$  with a cosine value of  $-\frac{\sqrt{2}}{2}$ . The angle that satisfies this is  $\cos^{-1}(-\frac{\sqrt{2}}{2}) = \frac{3\pi}{4}$ .

9. For  $\tan^{-1}(1)$ , we are looking for an angle in  $(-\frac{\pi}{2},\frac{\pi}{2})$  with a tangent value of 1. The angle that satisfies this is  $\tan^{-1}(1) = \frac{\pi}{4}$ .

11. For  $\tan^{-1}(-\sqrt{3})$ , we are looking for an angle in  $(-\frac{\pi}{2},\frac{\pi}{2})$  with a tangent value of  $-\sqrt{3}$ . The angle that satisfies this is  $\tan^{-1}(-\sqrt{3}) = -\frac{\pi}{3}$ .

13. In radian mode,  $\cos^{-1}(-0.4) \approx 1.9823$  rad or 1.9823. In degree mode,  $\cos^{-1}(-0.4) \approx 113.5782^\circ$ .

15. In radian mode,  $\sin^{-1}(-0.8) \approx -0.9273$  rad or  $-0.9273$ . In degree mode,  $\sin^{-1}(-0.8) \approx -53.131^\circ$ .

17.

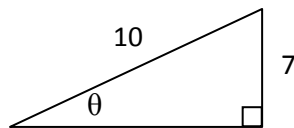

$$\sin(\theta) = \frac{\text{opposite}}{\text{hypotenuse}} = \frac{7}{10} = 0.7$$

So  $\theta = \sin^{-1}(0.7) \approx 0.7754$ .

19.  $\sin^{-1}\left(\cos\left(\frac{\pi}{4}\right)\right) = \sin^{-1}\left(\frac{\sqrt{2}}{2}\right)$ . For  $\sin^{-1}\left(\frac{\sqrt{2}}{2}\right)$ , we are looking for an angle in  $\left[-\frac{\pi}{2}, \frac{\pi}{2}\right]$  with a sine value of  $\frac{\sqrt{2}}{2}$ . The angle that satisfies this is  $\sin^{-1}\left(\frac{\sqrt{2}}{2}\right) = \frac{\pi}{4}$ . So  $\sin^{-1}\left(\cos\left(\frac{\pi}{4}\right)\right) = \sin^{-1}\left(\frac{\sqrt{2}}{2}\right) = \frac{\pi}{4}$ .

21.  $\sin^{-1}\left(\cos\left(\frac{4\pi}{3}\right)\right) = \sin^{-1}\left(-\frac{1}{2}\right)$ . For  $\sin^{-1}\left(-\frac{1}{2}\right)$ , we are looking for an angle in  $\left[-\frac{\pi}{2}, \frac{\pi}{2}\right]$  with a sine value of  $-\frac{1}{2}$ . The angle that satisfies this is  $\sin^{-1}\left(-\frac{1}{2}\right) = -\frac{\pi}{6}$ . So  $\sin^{-1}\left(\cos\left(\frac{4\pi}{3}\right)\right) = \sin^{-1}\left(-\frac{1}{2}\right) = -\frac{\pi}{6}$ .

23. Let  $x = \sin^{-1}\left(\frac{3}{7}\right)$ . Then  $\sin(x) = \frac{3}{7} = \frac{\text{opposite}}{\text{hypotenuse}}$ .

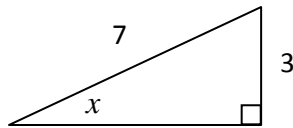

Using the Pythagorean Theorem, we can find the adjacent of the triangle:

$$3^2 + \text{adjacent}^2 = 7^2$$

$$\text{adjacent}^2 = 7^2 - 3^2 = 49 - 9 = 40$$

$$\text{adjacent} = \sqrt{40} = 2\sqrt{10}$$

Therefore,  $\cos\left(\sin^{-1}\left(\frac{3}{7}\right)\right) = \cos(x) = \frac{\text{adjacent}}{\text{hypotenuse}} = \frac{2\sqrt{10}}{7}$ .

25. Let  $x = \tan^{-1}(4)$ , then  $\tan(x) = 4 = \frac{\text{opposite}}{\text{adjacent}}$ .



Using the Pythagorean Theorem, we can find the hypotenuse of the triangle:

$$\text{hypotenuse}^2 = 1^2 + 4^2 = 1 + 16 = 17$$

$$\text{hypotenuse} = \sqrt{17}$$

Therefore,  $\cos(\tan^{-1}(4)) = \cos(x) = \frac{\text{adjacent}}{\text{hypotenuse}} = \frac{1}{\sqrt{17}}$ .

27. Let  $\theta = \cos^{-1}\left(\frac{x}{5}\right)$ , then  $\cos(\theta) = \frac{x}{5} = \frac{\text{adjacent}}{\text{hypotenuse}}$

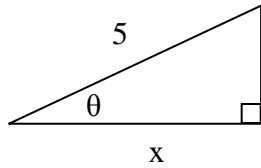

Using the Pythagorean Theorem, we can find the opposite of the triangle:

$$x^2 + \text{opposite}^2 = 5^2 = 25$$

$$\text{opposite}^2 = 25 - x^2$$

$$\text{opposite} = \sqrt{25 - x^2}$$

Therefore,  $\sin\left(\cos^{-1}\left(\frac{x}{5}\right)\right) = \sin(\theta) = \frac{\text{opposite}}{\text{hypotenuse}} = \frac{\sqrt{25 - x^2}}{5}$ .

29. Let  $\theta = \tan^{-1}(3x)$ , then  $\tan(\theta) = 3x = \frac{\text{opposite}}{\text{adjacent}}$

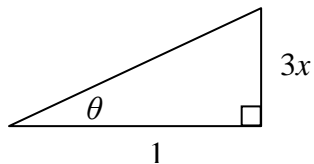

Using the Pythagorean Theorem, we can find the hypotenuse of the triangle:



$$\text{hypotenuse}^2 = (3x)^2 + 1^2 = 9x^2 + 1$$

$$\text{hypotenuse} = \sqrt{9x^2 + 1}$$

$$\text{Therefore, } \sin(\tan^{-1}(3x)) = \sin(\theta) = \frac{\text{opposite}}{\text{hypotenuse}} = \frac{3x}{\sqrt{9x^2 + 1}}.$$

## 6.4 Solutions to Exercises

1.  $2 \sin(\theta) = -\sqrt{2}$

$$\sin(\theta) = \frac{-\sqrt{2}}{2}$$

$$\theta = \frac{5\pi}{4} + 2k\pi \text{ or } \theta = \pi - \frac{\pi}{4} + 2k\pi = \frac{7\pi}{4} + 2k\pi, \text{ for } k \in \mathbb{Z}.$$

$$\text{Since } 0 \leq \theta < 2\pi, \text{ the answers should be } \theta = \frac{5\pi}{4} \text{ and } \theta = \frac{7\pi}{4}.$$

3.  $2 \cos(\theta) = 1$

$$\cos(\theta) = \frac{1}{2}$$

$$\theta = \frac{\pi}{3} + 2k\pi \text{ or } \theta = 2\pi - \frac{\pi}{3} + 2k\pi = \frac{5\pi}{3} + 2k\pi, \text{ for } k \in \mathbb{Z}.$$

$$\text{Since } 0 \leq \theta < 2\pi, \text{ the answers should be } \theta = \frac{\pi}{3} \text{ and } \theta = \frac{5\pi}{3}.$$

5.  $\sin(\theta) = 1$

$$\theta = \frac{\pi}{2} + 2k\pi, \text{ for } k \in \mathbb{Z}.$$

$$\text{Since } 0 \leq \theta < 2\pi, \text{ the answer should be } \theta = \frac{\pi}{2}.$$

7.  $\cos(\theta) = 0$

$$\theta = \frac{\pi}{2} + 2k\pi \text{ or } \theta = 2\pi - \frac{\pi}{2} + 2k\pi = \frac{3\pi}{2} + 2k\pi, \text{ for } k \in \mathbb{Z}.$$

$$\text{Since } 0 \leq \theta < 2\pi, \text{ the answers should be } \theta = \frac{\pi}{2} \text{ and } \theta = \frac{3\pi}{2}.$$

9.  $2 \cos(\theta) = \sqrt{2}$

$$\cos(\theta) = \frac{\sqrt{2}}{2}$$

$$\theta = \frac{\pi}{4} + 2k\pi \text{ or } \theta = 2\pi - \frac{\pi}{4} + 2k\pi = \frac{7\pi}{4} + 2k\pi, \text{ for } k \in \mathbb{Z}.$$

$$11. 2 \sin(\theta) = -1$$

$$\sin(\theta) = -\frac{1}{2}$$

$$\theta = \frac{7\pi}{6} + 2k\pi \text{ or } \theta = \frac{11\pi}{6} + 2k\pi, \text{ for } k \in \mathbb{Z}.$$

$$13. 2 \sin(3\theta) = 1$$

$$\sin(3\theta) = \frac{1}{2}$$

$$3\theta = \frac{\pi}{6} + 2k\pi \text{ or } 3\theta = \frac{5\pi}{6} + 2k\pi, \text{ for } k \in \mathbb{Z}$$

$$\theta = \frac{\pi}{18} + \frac{2k\pi}{3} \text{ or } \theta = \frac{5\pi}{18} + \frac{2k\pi}{3}, \text{ for } k \in \mathbb{Z}.$$

$$15. 2 \sin(3\theta) = -\sqrt{2}$$

$$\sin(3\theta) = -\frac{\sqrt{2}}{2}$$

$$3\theta = \frac{5\pi}{4} + 2k\pi \text{ or } 3\theta = \frac{7\pi}{4} + 2k\pi, \text{ for } k \in \mathbb{Z}$$

$$\theta = \frac{5\pi}{12} + \frac{2k\pi}{3} \text{ or } \theta = \frac{7\pi}{12} + \frac{2k\pi}{3}, \text{ for } k \in \mathbb{Z}.$$

$$17. 2 \cos(2\theta) = 1$$

$$\cos(2\theta) = \frac{1}{2}$$

$$2\theta = \frac{\pi}{3} + 2k\pi \text{ or } 2\theta = \frac{5\pi}{3} + 2k\pi, \text{ for } k \in \mathbb{Z}$$

$$\theta = \frac{\pi}{6} + k\pi \text{ or } \theta = \frac{5\pi}{6} + k\pi, \text{ for } k \in \mathbb{Z}.$$

$$19. 2 \cos(3\theta) = -\sqrt{2}$$

$$\cos(3\theta) = -\frac{\sqrt{2}}{2}$$

$$3\theta = \frac{3\pi}{4} + 2k\pi \text{ or } 3\theta = \frac{5\pi}{4} + 2k\pi, \text{ for } k \in \mathbb{Z}$$

$$\theta = \frac{\pi}{4} + \frac{2k\pi}{3} \text{ or } \theta = \frac{5\pi}{12} + \frac{2k\pi}{3}, \text{ for } k \in \mathbb{Z}.$$

$$21. \cos\left(\frac{\pi}{4}\theta\right) = -1$$

$$\frac{\pi}{4}\theta = \pi + 2k\pi, \text{ for } k \in \mathbb{Z}$$

$$\theta = 4 + 8k, \text{ for } k \in \mathbb{Z}.$$

$$23. 2 \sin(\pi\theta) = 1$$

$$\sin(\pi\theta) = \frac{1}{2}$$

$$\pi\theta = \frac{\pi}{6} + 2k\pi \text{ or } \pi\theta = \frac{5\pi}{6} + 2k\pi, \text{ for } k \in \mathbb{Z}$$

$$\theta = \frac{1}{6} + 2k \text{ or } \theta = \frac{5}{6} + 2k, \text{ for } k \in \mathbb{Z}.$$

$$25. \sin(x) = 0.27$$

$$x = \sin^{-1}(0.27)$$

$$x = 0.2734 + 2k\pi \text{ or } x = \pi - 0.2734 + 2k\pi, \text{ for } k \in \mathbb{Z}.$$

Since  $0 \leq x < 2\pi$ , there are two answers,  $x = 0.2734$  and  $x = \pi - 0.2734 = 2.8682$ .

$$27. \sin(x) = -0.58$$

$$x = \sin^{-1}(-0.58)$$

$$x = -0.6187 + 2k\pi \text{ or } x = \pi - (-0.6187) + 2k\pi, \text{ for } k \in \mathbb{Z}.$$

Since  $0 \leq x < 2\pi$ , there are two answers,  $x = -0.6187 + 2\pi = 5.6645$  and  $x = \pi - (-0.6187) = 3.7603$ .

$$29. \cos(x) = -0.55$$

$$x = \cos^{-1}(-0.55)$$

$$x = 2.1532 + 2k\pi \text{ or } x = 2\pi - 2.1532 + 2k\pi, \text{ for } k \in \mathbb{Z}.$$

Since  $0 \leq x < 2\pi$ , there are two answers,  $x = 2.1532$  and  $x = 2\pi - 2.1532 = 4.13$ .

$$31. \cos(x) = 0.71$$

$$x = \cos^{-1}(0.71)$$

$$x = 0.7813 + 2k\pi \text{ or } x = 2\pi - 0.7813 + 2k\pi, \text{ for } k \in \mathbb{Z}.$$

Since  $0 \leq x < 2\pi$ , there are two answers,  $x = 0.7813$  or  $x = 2\pi - 0.7813 = 5.5019$ .

$$33. 7\sin(6x) = 2$$

$$\sin(6x) = \frac{2}{7}$$

$$6x = \sin^{-1}\left(\frac{2}{7}\right)$$

$$6x = 0.28975 + 2k\pi \text{ or } 6x = \pi - 0.28975 + 2k\pi, \text{ for } k \in \mathbb{Z}.$$

In order to get the first two positive solutions,  $k = 0$ . This leads to:

$$6x = 0.28975 \text{ or } 6x = \pi - 0.28975 = 2.85184$$

$$x = 0.04829 \text{ or } x = 0.47531$$

$$35. 5\cos(3x) = -3$$

$$\cos(3x) = -\frac{3}{5}$$

$$3x = \cos^{-1}\left(-\frac{3}{5}\right)$$

$$3x = 2.2143 + 2k\pi \text{ or } 3x = 2\pi - 2.2143 + 2k\pi, \text{ for } k \in \mathbb{Z}.$$

In order to get the first two positive solutions,  $k = 0$ . This leads to:

$$3x = 2.2143 \text{ or } 3x = 2\pi - 2.2143 = 4.0689$$

$$x = 0.7381 \text{ or } x = 1.3563$$

$$37. 3\sin\left(\frac{\pi}{4}x\right) = 2$$

$$\sin\left(\frac{\pi}{4}x\right) = \frac{2}{3}$$

$$\frac{\pi}{4}x = \sin^{-1}\left(\frac{2}{3}\right)$$

$$\frac{\pi}{4}x = 0.72973 + 2k\pi \text{ or } \frac{\pi}{4}x = \pi - 0.72973 + 2k\pi, \text{ for } k \in \mathbb{Z}.$$

In order to get the first two positive solutions,  $k = 0$ . This leads to:

$$\frac{\pi}{4}x = 0.72973 \text{ or } \frac{\pi}{4}x = \pi - 0.72973 = 2.41186$$

$$x = 0.9291 \text{ or } x = 3.0709$$

$$39. 5\cos\left(\frac{\pi}{3}x\right) = 1$$

$$\cos\left(\frac{\pi}{3}x\right) = \frac{1}{5}$$

$$\frac{\pi}{3}x = \cos^{-1}\left(\frac{1}{5}\right)$$

$$\frac{\pi}{3}x = 1.3694 + 2k\pi \text{ or } \frac{\pi}{3}x = 2\pi - 1.3694 + 2k\pi, \text{ for } k \in \mathbb{Z}.$$

In order to get the first two positive solutions,  $k = 0$ . This leads to:

$$\frac{\pi}{3}x = 1.3694 \text{ or } \frac{\pi}{3}x = 2\pi - 1.3694 = 4.9138$$

$$x = 1.3077 \text{ or } x = 4.6923$$

## 6.5 Solutions to Exercises

$$1. c = \sqrt{5^2 + 8^2} = \sqrt{89}$$

$$A = \tan^{-1}(8/5) \approx 57.9946^\circ$$

$$B = \tan^{-1}(5/8) \approx 32.0054^\circ$$

$$3. b^2 = 15^2 - 7^2, b = \sqrt{225 - 49} = \sqrt{176}$$

$$A = \sin^{-1}(7/15) \approx 27.8181^\circ$$

$$B = \cos^{-1}(7/15) \approx 62.1819^\circ$$

5. Note that the function has a maximum of 10 and a minimum of -2. The function returns to its maximum or minimum every 4 units in the x direction, so the period is 4.

Midline = 4 because 4 lies equidistant from the function's maximum and minimum.

$$\text{Amplitude} = 10 - 4 \text{ or } 4 - (-2) = 6$$

$$\text{Horizontal compression factor} = \frac{2\pi}{\text{period}} = \frac{2\pi}{4} = \frac{\pi}{2}$$

If we choose to model this function with a sine curve, then a horizontal shift is required.  $\sin(x)$  will begin its period at the midline, but our function first reaches its midline at  $x=1$ . To adjust for this, we can apply a horizontal shift of -1.

$$\text{Therefore, we may model this function with } y(x) = 6 \sin\left(\frac{\pi}{2}(x - 1)\right) + 4$$

7. We are given when the minimum temperature first occurs, so it would be a good choice to create our model based on a flipped cosine curve with a period of 24 hours.

$$\text{Amplitude} = \frac{63 - 37}{2} = 13$$

$$\text{Midline} = \frac{63 + 37}{2} = 50$$

$$\text{Horizontal stretch factor} = \frac{2\pi}{24} = \frac{\pi}{12}$$

$$\text{Horizontal shift} = -5$$

Using this information we have the following model:  $D(t) = -13 \cos\left(\frac{\pi}{12}(t - 5)\right) + 50$

9. a. We are given when the population is at a minimum, so we can create a model using a flipped cosine curve with a period of 12 months.

$$\text{Midline} = 129$$

$$\text{Amplitude} = 25$$

$$\text{Horizontal stretch factor} = \frac{2\pi}{12} = \frac{\pi}{6}$$

Using this information we have the following model:  $P(t) = -25 \cos\left(\frac{\pi}{6}(t)\right) + 129$

b. April is 3 months after January which means that we may use the previous model with a rightward shift of 3 months.  $P(t) = -25 \cos\left(\frac{\pi}{6}(t - 3)\right) + 129$

11. Let  $D(t)$  be the temperature in farenheight at time  $t$ , where  $t$  is measured in hours since midnight. We know when the maximum temperature occurs so we can create a model using a cosine curve.

$$\text{Midline} = 85$$

$$\text{Amplitude} = 105 - 85 = 20$$

$$\text{Horizontal stretch factor} = \frac{2\pi}{24} = \frac{\pi}{12}$$

$$\text{Horizontal shift} = -17$$

Using this information we have the following model:  $D(t) = 20 \cos\left(\frac{\pi}{12}(t - 17)\right) + 85$

$$D(9) = 20 \cos\left(\frac{\pi}{12}(9 - 17)\right) + 85 = 75$$

Therefore the temperature at 9 AM was 75° F.

13. Let  $D(t)$  be the temperature in farenheight at time  $t$ , where  $t$  is measured in hours since midnight. We know when the average temperature first occurs so we can create a model using a sine curve. The average temperature occurs at 10 AM we can assume that the temperature increases after that.

$$\text{Midline} = \frac{63 + 47}{2} = 55$$

$$\text{Amplitude} = \frac{63 - 47}{2} = 8$$

$$\text{Horizontal stretch factor} = \frac{2\pi}{24} = \frac{\pi}{12}$$

$$\text{Horizontal shift} = -10$$

$$D(t) = 8 \sin\left(\frac{\pi}{12}(t - 10)\right) + 55$$

To calculate when the temperature will first be 51°F we set  $D(t) = 51$  and solve for  $t$ .

$$51 = 8 \sin\left(\frac{\pi}{12}(t - 10)\right) + 55$$

$$\sin\left(\frac{\pi}{12}(t - 10)\right) = -\frac{1}{2}$$

$$\frac{\pi}{12}(t - 10) = \sin^{-1}\left(-\frac{1}{2}\right)$$

$$t = \frac{-\pi/6}{\pi/12} + 10 = 8$$

The first time the temperature reaches 51°F for the day is at 8 AM, 8 hours past midnight.

15. Let  $h(t)$  be the height from the ground in meters of your seat on the ferris wheel at a time  $t$ , where  $t$  is measured in minutes. The minimum is level with the platform at 2 meters, and the maximum is the 2 meter platform plus the 20 meter diameter. Since you begin the ride at a minimum, a flipped cosine function would be ideal for modeling this situation with a period being a full revolution.

$$\text{Midline} = \frac{22+2}{2} = 12$$

$$\text{Amplitude} = \frac{22-2}{2} = 10$$

$$\text{Horizontal compression factor} = \frac{2\pi}{6} = \frac{\pi}{3}$$

$$\text{Putting this information gives us } h(t) = -10 \cos\left(\frac{\pi}{3}(t)\right) + 12$$

To find the amount of time which the height is above 13 meters, we can set  $h(t) = 13$  and find both values of  $t$  for which this is true and take their difference.

$$13 = -10 \cos\left(\frac{\pi}{3}(t)\right) + 12$$

$$\cos\left(\frac{\pi}{3}(t)\right) = -\frac{1}{10}$$

$$\frac{\pi}{3}t_1 = \cos^{-1}\left(-\frac{1}{10}\right) \text{ and } \frac{\pi}{3}t_2 = 2\pi - \cos^{-1}\left(-\frac{1}{10}\right)$$



$$t_1 - t_2 = \frac{3}{\pi} (2\pi - \cos^{-1}(-\frac{1}{10}) - \cos^{-1}(-\frac{1}{10})) \approx 2.80869431742$$

Therefore you would be 13 meters or more above the ground for about 2.8 minutes during the ride.

17. Let  $S(t)$  be the amount of sea ice around the north pole in millions of square meters at time  $t$ , where  $t$  is the number of months since January. Since we know when the maximum occurs, a cosine curve would be useful in modeling this situation.

$$\text{Midline} = \frac{6+14}{2} = 10$$

$$\text{Amplitude} = \frac{6-14}{2} = 4$$

$$\text{Horizontal stretch factor} = \frac{2\pi}{12} = \frac{\pi}{6}$$

$$\text{Horizontal shift} = -2$$

$$\text{Therefore } S(t) = 4 \cos\left(\frac{\pi}{6}(t - 2)\right) + 10$$

To find where there will be less than 9 million square meters of sea ice we need to set  $S(t) = 9$  and find the difference between the two  $t$  values in which this is true during a single period.

$$4 \cos\left(\frac{\pi}{6}(t - 2)\right) + 10 = 9$$

$$\cos\left(\frac{\pi}{6}(t - 2)\right) = -\frac{1}{4}$$

$$\frac{\pi}{6}(t_1 - 2) = \cos^{-1}\left(-\frac{1}{4}\right) \text{ and } \frac{\pi}{6}(t_2 - 2) = 2\pi - \cos^{-1}\left(-\frac{1}{4}\right)$$

Solving these equations gives:

$$t_1 = \frac{6}{\pi} \left( \cos^{-1}\left(-\frac{1}{4}\right) \right) + 2 \approx 5.4825837$$

$$t_2 = \frac{6}{\pi} \left( 2\pi - \cos^{-1}\left(-\frac{1}{4}\right) \right) + 2 \approx 10.5174162$$

$$t_1 - t_2 \approx 5.0348325$$

Therefore there are approximately 5.035 months where there is less than 9 million square meters of sea ice around the north pole in a year.

19. a. We are given when the smallest breath occurs, so we can model this using a flipped cosine function. We're not explicitly told the period of the function, but we're given when the largest and smallest breath occurs. It takes half of cosine's period to go from the smallest to largest value. We can find the period by doubling the difference of the  $t$  values that correspond to the largest and smallest values.

$$\text{Period} = 2(55 - 5) = 100$$

$$\text{Midline} = \frac{0.6 + 1.8}{2} = 1.2$$

$$\text{Amplitude} = \frac{1.8 - 0.6}{2} = 0.6$$

$$\text{Horizontal shift} = -5$$

$$\text{Horizontal stretch factor} = \frac{2\pi}{100} = \frac{\pi}{50}$$

$$\text{This gives us } b(t) = 1.2 - 0.6 \cos\left(\frac{\pi}{50}(t - 5)\right).$$

$$b. \quad b(5) = 1.2 - 0.6 \cos\left(\frac{\pi}{50}(5 - 5)\right) = 0.6$$

$$b(10) = 1.2 - 0.6 \cos\left(\frac{\pi}{50}(10 - 5)\right) \approx 0.63$$

$$b(15) = 1.2 - 0.6 \cos\left(\frac{\pi}{50}(15 - 5)\right) \approx 0.71$$

$$b(20) = 1.2 - 0.6 \cos\left(\frac{\pi}{50}(20 - 5)\right) \approx 0.85$$

$$b(25) = 1.2 - 0.6 \cos\left(\frac{\pi}{50}(25 - 5)\right) \approx 1.01$$

$$b(30) = 1.2 - 0.6 \cos\left(\frac{\pi}{50}(30 - 5)\right) = 1.2$$

$$b(35) = 1.2 - 0.6 \cos\left(\frac{\pi}{50}(35 - 5)\right) \approx 1.39$$

$$b(40) = 1.2 - 0.6 \cos\left(\frac{\pi}{50}(40 - 5)\right) \approx 1.55$$

$$b(45) = 1.2 - 0.6 \cos\left(\frac{\pi}{50}(45 - 5)\right) \approx 1.69$$

$$b(50) = 1.2 - 0.6 \cos\left(\frac{\pi}{50}(50 - 5)\right) \approx 1.77$$

$$b(55) = 1.2 - 0.6 \cos\left(\frac{\pi}{50}(55 - 5)\right) = 1.8$$

$$b(60) = 1.2 - 0.6 \cos\left(\frac{\pi}{50}(60 - 5)\right) \approx 1.77$$

21. a. From either right triangle in the image,  $\sin(\alpha) = \frac{3960}{3960+t}$ , so  $\alpha(t) = \sin^{-1}\left(\frac{3960}{3960+t}\right)$ .

b.  $\alpha(30,000) = \sin^{-1}\left(\frac{3960}{3960+30000}\right)$ . The angle opposite of alpha is  $90^\circ - \alpha \approx 83.304^\circ$ . Twice this angle would be  $166.608^\circ$ , which is the angle of one end of the satellite's coverage on earth to the other end. The ratio of this angle to the  $360^\circ$  angle needed to cover the entire earth is  $\frac{166.608^\circ}{360^\circ} = .4628$  or 46.28%. Therefore it would take 3 satellites to cover the entire circumference of the earth.

c. Using the same methods as in 21b, we find  $\alpha = 52.976^\circ$ . The angle between one end of the satellite's coverage to the other is  $2(90^\circ - 52.976^\circ) = 74.047^\circ$ . The ratio of this angle to the  $360^\circ$  angle needed to cover the entire earth is  $\frac{74.047^\circ}{360^\circ} \approx 0.206$ . Therefore roughly 20.6% of the earth's circumference can be covered by one satellite. This means that you would need 5 satellites to cover the earth's circumference.

d. Using the same methods as in 21b and 21c we can solve for  $t$ .  $\alpha = \sin^{-1}\left(\frac{3960}{3960+t}\right)$ . So the angle from one end of the satellite's coverage to the other is  $2\left(90^\circ - \sin^{-1}\left(\frac{3960}{3960+t}\right)\right)$ . The ratio of this angle to the  $360^\circ$  angle needed to cover the earth is 0.2, so we have:

$$\frac{2\left(90^\circ - \sin^{-1}\left(\frac{3960}{3960+t}\right)\right)}{360^\circ} = 0.2$$

$$90^\circ - \sin^{-1}\left(\frac{3960}{3960 + t}\right) = 36^\circ$$

$$\sin^{-1}\left(\frac{3960}{3960 + t}\right) = 54^\circ$$

$$\frac{3960}{3960 + t} = \sin(54^\circ)$$

$$3960 \sin(54^\circ) + t \sin(54^\circ) = 3960$$

$$t = 3960 \frac{1 - \sin(54^\circ)}{\sin(54^\circ)} \approx 934.829$$

To cover 20% of the earth's circumference, a satellite would need to be placed approximately 934.829 miles from the earth's surface.

## 7.1 Solutions to Exercises

1. Dividing both sides by 2, we have  $\sin \theta = -\frac{1}{2}$ . Since  $\sin \theta$  is negative only in quadrants III and IV, using our knowledge of special angles,  $\theta = \frac{7\pi}{6}$  or  $\theta = \frac{11\pi}{6}$ .

3. Dividing both sides by 2,  $\cos \theta = \frac{1}{2}$ . Using our knowledge of quadrants, this occurs in quadrants I and IV. In quadrant I,  $\theta = \frac{\pi}{3}$ ; in quadrant IV,  $\theta = \frac{5\pi}{3}$ .

5. Start by dividing both sides by 2 to get  $\sin\left(\frac{\pi}{4}x\right) = \frac{1}{2}$ . We know that  $\sin \theta = \frac{1}{2}$  for  $\theta = \frac{\pi}{6} + 2k\pi$  and  $\theta = \frac{5\pi}{6} + k\pi$  for any integer  $k$ . Therefore,  $\frac{\pi}{4}x = \frac{\pi}{6} + 2k\pi$  and  $\frac{\pi}{4}x = \frac{5\pi}{6} + 2k\pi$ . Solving the first equation by multiplying both sides by  $\frac{4}{\pi}$  (the reciprocal of  $\frac{\pi}{4}$ ) and distributing, we get  $x = \frac{4}{6} + 8k$ , or  $x = \frac{2}{3} + 8k$ . The second equation is solved in exactly the same way to arrive at  $x = \frac{10}{3} + 8k$ .

7. Divide both sides by 2 to arrive at  $\cos 2t = -\frac{\sqrt{3}}{2}$ . Since  $\cos \theta = -\frac{\sqrt{3}}{2}$  when  $\theta = \frac{5\pi}{6} + 2k\pi$  and when  $\theta = \frac{7\pi}{6} + 2k\pi$ . Thus,  $2t = \frac{5\pi}{6} + 2k\pi$  and  $2t = \frac{7\pi}{6} + 2k\pi$ . Solving these equations for  $t$  results in  $t = \frac{5\pi}{12} + k\pi$  and  $t = \frac{7\pi}{12} + k\pi$ .

9. Divide both sides by 3; then,  $\cos\left(\frac{\pi}{5}x\right) = \frac{2}{3}$ . Since  $\frac{2}{3}$  is not the cosine of any special angle we know, we must first determine the angles in the interval  $[0, 2\pi)$  that have a cosine of  $\frac{2}{3}$ . Your calculator will calculate  $\cos^{-1}\left(\frac{2}{3}\right)$  as approximately 0.8411. But remember that, by definition,  $\cos^{-1} \theta$  will always have a value in the interval  $[0, \pi]$  -- and that there will be another angle in  $(\pi, 2\pi)$  that has the same cosine value. In this case, 0.8411 is in quadrant I, so the other angle must be in quadrant IV:  $2\pi - 0.8411 \approx 5.4421$ . Therefore,  $\frac{\pi}{5}x = 0.8411 + 2k\pi$  and  $\frac{\pi}{5}x = 5.442 + 2k\pi$ . Multiplying both sides of both equations by  $\frac{5}{\pi}$  gives us  $x = 1.3387 + 10k$  and  $x = 8.6612 + 10k$ .

11. Divide both sides by 7:  $\sin 3t = -\frac{2}{7}$ . We need to know the values of  $\theta$  that give us  $\sin \theta = -\frac{2}{7}$ . Your calculator provides one answer:  $\sin^{-1}\left(-\frac{2}{7}\right) \approx -0.2898$ . However,  $\sin^{-1} \theta$  has a range of  $\left[-\frac{\pi}{2}, \frac{\pi}{2}\right]$ , which only covers quadrants I and IV. There is another angle in the interval  $\left(\frac{\pi}{2}, \frac{3\pi}{2}\right)$  with the same sine value; in this case, in quadrant III:  $\pi + 0.2898 \approx 3.4314$ . Therefore,  $3t = -0.2898 + 2k\pi$  and  $3t = 3.4314 + 2k\pi$ . Dividing both sides of both equations by 3 gives us  $t = 1.1438 + \frac{2\pi}{3}k$  and  $t = -0.0966 + \frac{2\pi}{3}k$ .

13. Resist the urge to divide both sides by  $\cos x$  -- although you can do this, you then have to separately consider the case where  $\cos x = 0$ . Instead, regroup all expressions onto one side of the equation:

$$10 \sin x \cos x - 6 \cos x = 0$$

Now factor  $\cos x$ :

$$\cos x (10 \sin x - 6) = 0$$

So either  $\cos x = 0$  or  $10 \sin x - 6 = 0$ . On the interval  $[0, 2\pi)$ ,  $\cos x = 0$  at  $x = \frac{\pi}{2}$  and  $x = \frac{3\pi}{2}$ , which provides us with two solutions. If  $10 \sin x - 6 = 0$ , then  $10 \sin x = 6$  and  $\sin x = \frac{6}{10}$ .

Using a calculator or computer to calculate  $\sin^{-1} \frac{6}{10}$  gives us approximately 0.644, which is in quadrant I. We know there is another value for  $x$  in the interval  $[0, 2\pi)$ : in quadrant II at

$\pi - 0.644 \approx 2.498$ . Our solutions are  $\frac{\pi}{2}, \frac{3\pi}{2}, 0.644$  and  $2.498$ .

15. Add 9 to both sides to get  $\csc 2x = 9$ . If we rewrite this as  $\frac{1}{\sin 2x} = 9$ , we have  $9 \sin 2x = 1$  and  $\sin 2x = \frac{1}{9}$ .  $\sin \theta = \frac{1}{9}$  at  $\theta \approx 0.1113$  (the value from a calculator) and  $\theta \approx 3.0303$  (using the reference angle in quadrant II). Therefore,  $2x = 0.1113 + 2k\pi$  and  $2x = 3.0303 + 2k\pi$ . Solving these equations gives us  $x = 0.056 + k\pi$  and  $x = 1.515 + k\pi$  for integral  $k$ . We choose  $k = 0$  and  $k = 1$  for both equations to get four values: 0.056, 1.515, 3.198 and 4.657; these are the only values that lie in the interval  $[0, 2\pi)$ .

17. Factoring  $\sin x$ , we get  $\sin x (\sec x - 2) = 0$ . Therefore, either  $\sin x = 0$  or  $\sec x - 2 = 0$ . On the interval  $[0, 2\pi)$ ,  $\sin x = 0$  at  $x = 0$  and  $x = \pi$ , so these are our first two answers.

If  $\sec x - 2 = 0$ , then  $\sec x = 2$  and  $\frac{1}{\cos x} = 2$ . This leads us to  $2 \cos x = 1$  and  $\cos x = \frac{1}{2}$ .

Recognizing this as a well-known angle, we conclude that (again, on the interval  $[0, 2\pi)$ ),  $x = \frac{\pi}{3}$  and  $x = \frac{5\pi}{3}$ .

19. If  $\sin^2(x) = \frac{1}{4}$ , then  $\sin x = \pm \frac{1}{2}$ . On the interval  $[0, 2\pi)$ , this occurs at  $x = \frac{\pi}{6}$ ,  $x = \frac{5\pi}{6}$ ,  $x = \frac{7\pi}{6}$  and  $x = \frac{11\pi}{6}$ .

21. If  $\sec^2 x = 7$ , then  $\sec x = \pm\sqrt{7}$ ,  $\frac{1}{\cos x} = \pm\sqrt{7}$ , and  $\cos x = \pm\frac{1}{\sqrt{7}} = \pm\frac{\sqrt{7}}{7}$ .

Using a calculator for  $\cos^{-1}\left(\frac{\sqrt{7}}{7}\right)$ , we get  $x \approx 1.183$ . There is another angle on the interval  $[0, 2\pi)$  whose cosine is  $\frac{1}{\sqrt{7}}$ , in quadrant IV:  $x = 2\pi - 1.183 \approx 5.1$ . The two angles where  $\cos x = -\frac{\sqrt{7}}{7}$  must lie in quadrants III and IV at  $x = \pi - 1.183 \approx 1.959$  and  $x = \pi + 1.183 \approx 4.325$ .

23. This is quadratic in  $\sin w$ : think of it as  $2x^2 + 3x + 1 = 0$ , where  $x = \sin w$ . This is simple enough to factor:

$$2x^2 + 3x + 1 = (2x + 1)(x + 1) = 0$$

This means that either  $2x + 1 = 0$  and  $x = -\frac{1}{2}$ , or  $x + 1 = 0$  and  $x = -1$ . Therefore, either  $\sin w = -\frac{1}{2}$  or  $\sin w = -1$ . We know these special angles: these occur on the interval  $[0, 2\pi)$  when  $w = \frac{7\pi}{6}$  or  $w = \frac{11\pi}{6}$  (for  $\sin w = -\frac{1}{2}$ ) or when  $w = \frac{3\pi}{2}$  (for  $\sin w = -1$ ).

25. If we subtract 1 from both sides, we can see that this is quadratic in  $\cos t$ :

$$2(\cos^2 t + \cos t - 1) = 0$$

If we let  $x = \cos t$ , we have:

$$2x^2 + x - 1 = (2x - 1)(x + 1) = 0$$

Either  $2x - 1 = 0$  and  $x = \frac{1}{2}$ , or  $x + 1 = 0$  and  $x = -1$ . Therefore,  $\cos t = \frac{1}{2}$  or  $\cos t = -1$ . On the interval  $[0, 2\pi)$ , these are true when  $t = \frac{\pi}{3}$  or  $t = \frac{5\pi}{3}$  (for  $\cos t = \frac{1}{2}$ ) or when  $t = \pi$  (for  $\cos t = -1$ ).

27. If we rearrange the equation, it is quadratic in  $\cos x$ :

$$4 \cos^2 x - 15 \cos x - 4 = 0$$

If we let  $u = \cos x$ , we can write this as:

$$4u^2 - 15u - 4 = 0$$

This factors as:

$$(4u + 1)(u - 4) = 0$$

Therefore, either  $4u + 1 = 0$  and  $u = -\frac{1}{4}$ , or  $u - 4 = 0$  and  $u = 4$ . Substituting back, we have:

$$\cos x = -\frac{1}{4}$$

We reject the other possibility that  $\cos x = 4$  since  $\cos x$  is always in the interval  $[-1, 1]$ .

Your calculator will tell you that  $\cos^{-1}\left(-\frac{1}{4}\right) \approx 1.823$ . This is in quadrant II, and the cosine is negative, so the other value must lie in quadrant III. The reference angle is  $\pi - 1.823$ , so the other angle is at  $\pi + (\pi - 1.823) = 2\pi - 1.823 \approx 4.460$ .

29. If we substitute  $1 - \cos^2 t$  for  $\sin^2 t$ , we can see that this is quadratic in  $\cos t$ :

$$12 \sin^2 t + \cos t - 6 = 12(1 - \cos^2 t) + \cos t - 6 = -12 \cos^2 t + \cos t + 6 = 0$$



Setting  $u = \cos t$ :

$$-12u^2 + u + 6 = (-4u + 3)(3u + 2) = 0$$

This leads us to  $-4u + 3 = 0$  or  $3u + 2 = 0$ , so either  $u = \frac{3}{4}$  or  $u = -\frac{2}{3}$ .

Substituting back,  $\cos t = \frac{3}{4}$  gives us (via a calculator)  $t \approx 0.7227$ . This is in quadrant I, so the corresponding angle must lie in quadrant IV at  $t = 2\pi - 0.7227 \approx 5.5605$ .

Similarly,  $\cos t = -\frac{2}{3}$  gives us  $t \approx 2.3005$ . This is in quadrant II; the corresponding angle with the same cosine value must be in quadrant III at  $t = 2\pi - 2.3005 \approx 3.9827$ .

31. Substitute  $1 - \sin^2 \phi$  for  $\cos^2 \phi$ :

$$1 - \sin^2 \phi = -6 \sin \phi$$

$$-\sin^2 \phi + 6 \sin \phi + 1 = 0$$

This is quadratic in  $\sin \phi$ , so set  $u = \sin \phi$  and we have:

$$-u^2 + 6u + 1 = 0$$

This does not factor easily, but the quadratic equation gives us:

$$u = \frac{-6 \pm \sqrt{36 - 4(-1)(1)}}{2(-1)} = \frac{-6 \pm \sqrt{40}}{-2} = \frac{-6 \pm 2\sqrt{10}}{-2} = 3 \pm \sqrt{10}$$

Thus,  $u \approx 6.1623$  and  $u \approx -0.1623$ . Substituting back, we have  $\sin \phi = -0.1623$ . We reject  $\sin \phi = 6.1623$  since  $\sin \phi$  is always between -1 and 1. Using a calculator to calculate  $\sin^{-1}(-0.1623)$ , we get  $\phi \approx -0.1630$ . Unfortunately, this is not in the required interval  $[0, 2\pi)$ , so we add  $2\pi$  to get  $\phi \approx 6.1202$ . This is in quadrant IV; the corresponding angle with the same sine value must be in quadrant III at  $\pi + 0.1630 \approx 3.3046$ .

33. If we immediately substitute  $v = \tan x$ , we can write:

$$v^3 = 3v$$

$$v^3 - 3v = 0$$

$$v(v^2 - 3) = 0$$

Thus, either  $v = 0$  or  $v^2 - 3 = 0$ , meaning  $v^2 = 3$  and  $v = \pm\sqrt{3}$ .

Substituting back,  $\tan x = 0$  at  $x = 0$  and  $x = \pi$ . Similarly,  $\tan x = \sqrt{3}$  at  $x = \frac{\pi}{3}$  and  $x = \frac{4\pi}{3}$  and  $\tan x = -\sqrt{3}$  at  $x = \frac{2\pi}{3}$  and  $x = \frac{5\pi}{3}$ .

35. Substitute  $v = \tan x$  so that:

$$v^5 = v$$

$$v^5 - v = 0$$

$$v(v^4 - 1) = 0$$

Either  $v = 0$  or  $v^4 - 1 = 0$  and  $v^4 = 1$  and  $v = \pm 1$ . Substituting back,  $\tan x = 0$  at  $x = 0$  and  $x = \pi$ . Similarly,  $\tan x = 1$  at  $x = \frac{\pi}{4}$  and  $x = \frac{5\pi}{4}$ . Finally,  $\tan x = -1$  for  $x = \frac{3\pi}{4}$  and  $x = \frac{7\pi}{4}$ .

37. The structure of the equation is not immediately apparent.

Substitute  $u = \sin x$  and  $v = \cos x$ , and we have:

$$4uv + 2u - 2v - 1 = 0$$

The structure is now reminiscent of the result of multiplying two binomials in different variables. For example,  $(x + 1)(y + 1) = xy + x + y + 1$ . In fact, our equation factors as:

$$(2u - 1)(2v + 1) = 0$$

Therefore, either  $2u - 1 = 0$  (and  $u = \frac{1}{2}$ ) or  $2v + 1 = 0$  (and  $v = -\frac{1}{2}$ ). Substituting back,  $\sin x = \frac{1}{2}$  or  $\cos x = -\frac{1}{2}$ . This leads to  $x = \frac{\pi}{6}, x = \frac{5\pi}{6}$  (for  $\sin x = \frac{1}{2}$ ) and  $x = \frac{2\pi}{3}, x = \frac{4\pi}{3}$  (for  $\cos x = -\frac{1}{2}$ )

39. Rewrite  $\tan x$  as  $\frac{\sin x}{\cos x}$  to give:

$$\frac{\sin x}{\cos x} - 3 \sin x = 0$$

Using a common denominator of  $\cos x$ , we have:

$$\frac{\sin x}{\cos x} - \frac{3 \sin x \cos x}{\cos x} = 0$$

and

$$\frac{\sin x - 3 \sin x \cos x}{\cos x} = 0$$

$$\sin x - 3 \sin x \cos x = 0$$

$$\sin x (1 - 3 \cos x) = 0$$

Therefore, either  $\sin x = 0$  or  $1 - 3 \cos x = 0$ , which means  $\cos x = \frac{1}{3}$ .

For  $\sin x = 0$ , we have  $x = 0$  and  $x = \pi$  on the interval  $[0, 2\pi)$ . For  $\cos x = \frac{1}{3}$ , we need  $\cos^{-1}\left(\frac{1}{3}\right)$ , which a calculator will indicate is approximately 1.231. This is in quadrant I, so the corresponding angle with a cosine of  $\frac{1}{3}$  is in quadrant IV at  $2\pi - 1.231 \approx 5.052$ .

41. Rewrite both  $\tan t$  and  $\sec t$  in terms of  $\sin t$  and  $\cos t$ :

$$2 \frac{\sin^2 t}{\cos^2 t} = 3 \frac{1}{\cos t}$$

We can multiply both sides by  $\cos^2 t$ :

$$2 \sin^2 t = 3 \cos t$$

Now, substitute  $1 - \cos^2 t$  for  $\sin^2 t$  to yield:

$$2(1 - \cos^2 t) - 3 \cos t = 0$$

This is beginning to look quadratic in  $\cos t$ . Distributing and rearranging, we get:

$$-2 \cos^2 t - 3 \cos t + 2 = 0$$

Substitute  $u = \cos t$ :

$$-2u^2 - 3u + 2 = 0$$

$$(-2u + 1)(u + 2) = 0$$

Therefore, either  $-2u + 1 = 0$  (and  $u = \frac{1}{2}$ ) or  $u + 2 = 0$  (and  $u = -2$ ). Since  $u = \cos t$  will never have a value of  $-2$ , we reject the second solution.

$\cos t = \frac{1}{2}$  at  $t = \frac{\pi}{3}$  and  $t = \frac{5\pi}{3}$  on the interval  $[0, 2\pi)$ .

## 7.2 Solutions to Exercises

$$1. \sin(75^\circ) = \sin(45^\circ + 30^\circ) = \sin(45^\circ)\cos(30^\circ) + \cos(45^\circ)\sin(30^\circ) = \frac{\sqrt{2}}{2} \cdot \frac{\sqrt{3}}{2} + \frac{\sqrt{2}}{2} \cdot \frac{1}{2} = \frac{\sqrt{6} + \sqrt{2}}{4}$$

$$3. \cos(165^\circ) = \cos(120^\circ + 45^\circ) = \cos(120^\circ)\cos(45^\circ) - \sin(120^\circ)\sin(45^\circ) = \frac{-\sqrt{6} + \sqrt{2}}{4}$$

$$5. \cos\left(\frac{7\pi}{12}\right) = \cos\left(\frac{\pi}{4} + \frac{\pi}{3}\right) = \cos\left(\frac{\pi}{4}\right)\cos\left(\frac{\pi}{3}\right) - \sin\left(\frac{\pi}{4}\right)\sin\left(\frac{\pi}{3}\right) = \frac{\sqrt{2} - \sqrt{6}}{4}$$

$$7. \sin\left(\frac{5\pi}{12}\right) = \sin\left(\frac{\pi}{6} + \frac{\pi}{4}\right) = \sin\left(\frac{\pi}{6}\right)\cos\left(\frac{\pi}{4}\right) + \cos\left(\frac{\pi}{6}\right)\sin\left(\frac{\pi}{4}\right) = \frac{\sqrt{6}+\sqrt{2}}{4}$$

$$9. \sin\left(x + \frac{11\pi}{6}\right) = \sin(x)\cos\left(\frac{11\pi}{6}\right) + \cos(x)\sin\left(\frac{11\pi}{6}\right) = \frac{\sqrt{3}}{2}\sin(x) - \frac{1}{2}\cos(x)$$

$$11. \cos\left(x - \frac{5\pi}{6}\right) = \cos(x)\cos\left(\frac{5\pi}{6}\right) + \sin(x)\sin\left(\frac{5\pi}{6}\right) = -\frac{\sqrt{3}}{2}\cos(x) + \frac{1}{2}\sin(x)$$

$$13. \csc\left(\frac{\pi}{2} - t\right) = \frac{1}{\sin\left(\frac{\pi}{2} - t\right)} = \frac{1}{\sin\left(\frac{\pi}{2}\right)\cos(t) - \cos\left(\frac{\pi}{2}\right)\sin(t)} = \frac{1}{\cos(t)} = \sec(t)$$

$$15. \cot\left(\frac{\pi}{2} - x\right) = \frac{\cos\left(\frac{\pi}{2}\right)\cos(x) + \sin\left(\frac{\pi}{2}\right)\sin(x)}{\sin\left(\frac{\pi}{2}\right)\cos(x) - \cos\left(\frac{\pi}{2}\right)\sin(x)} = \frac{\sin(x)}{\cos(x)} = \tan(x)$$

$$17. 16 \sin(16x) \sin(11x) = 16 \cdot \frac{1}{2} (\cos(16x - 11x) - \cos(16x + 11x)) = 8 \cos(5x) - 8 \cos(27x)$$

$$19. 2 \sin(5x) \cos(3x) = \sin(5x + 3x) + \sin(5x - 3x) = \sin(8x) + \sin(2x)$$

$$21. \cos(6t) + \cos(4t) = 2 \cos\left(\frac{6t+4t}{2}\right) \cos\left(\frac{6t-4t}{2}\right) = 2 \cos(5t) \cos(t)$$

$$23. \sin(3x) + \sin(7x) = 2 \sin\left(\frac{3x+7x}{2}\right) \cos\left(\frac{3x-7x}{2}\right) = 2 \sin(5x) \cos(-2x)$$

25. We know that  $\sin(a) = \frac{2}{3}$  and  $\cos(b) = -\frac{1}{4}$  and that the angles are in quadrant II. We can find  $\cos(a)$  and  $\sin(b)$  using the Pythagorean identity  $\sin^2(\theta) + \cos^2(\theta) = 1$ , or by using the known values of  $\sin(a)$  and  $\cos(b)$  to draw right triangles. Using the latter method: we know two sides of both a right triangle including angle  $a$  and a right triangle including angle  $b$ . The triangle including angle  $a$  has a hypotenuse of 3 and an opposite side of 2. We may use the Pythagorean theorem to find the side adjacent to angle  $a$ . Using the same method we may find the side opposite to  $b$ .

For the triangle containing angle  $a$ :

$$\text{Adjacent} = \sqrt{3^2 - 2^2} = \sqrt{5}$$

However, this side lies in quadrant II, so it will be  $-\sqrt{5}$ .

For the triangle containing angle  $b$ :

$$\text{Opposite} = \sqrt{4^2 - 1^2} = \sqrt{15}$$

In quadrant II,  $y$  is positive, so we do not need to change the sign.

From this, we know:  $\sin(a) = \frac{2}{3}$ ,  $\cos(a) = -\frac{\sqrt{5}}{3}$ ,  $\cos(b) = -\frac{1}{4}$ ,  $\sin(b) = \frac{\sqrt{15}}{4}$ .

a.  $\sin(a + b) = \sin(a)\cos(b) + \cos(a)\sin(b) = \frac{-2-5\sqrt{3}}{12}$

b.  $\cos(a - b) = \cos(a)\cos(b) + \sin(a)\sin(b) = \frac{\sqrt{5}+2\sqrt{15}}{12}$

27.  $\sin(3x)\cos(6x) - \cos(3x)\sin(6x) = -0.9$

$$\sin(3x - 6x) = -0.9$$

$$\sin(-3x) = -0.9$$

$$-\sin(3x) = -0.9$$

$3x = \sin^{-1}(0.9) + 2\pi k$  or  $3x = \pi - \sin^{-1}(0.9) + 2\pi k$ , where  $k$  is an integer

$$x = \frac{\sin^{-1}(0.9) + 2\pi k}{3} \text{ or } x = \frac{\pi - \sin^{-1}(0.9) + 2\pi k}{3}$$

$$x \approx 0.373 + \frac{2\pi}{3}k \text{ or } x \approx 0.674 + \frac{2\pi}{3}k, \text{ where } k \text{ is an integer}$$

29.  $\cos(2x)\cos(x) + \sin(2x)\sin(x) = 1$

$$\cos(2x - x) = 1$$

$$x = 0 + 2\pi k, \text{ where } k \text{ is an integer}$$

31.  $\cos(5x) = -\cos(2x)$

$$\cos(5x) + \cos(2x) = 0$$

$$2 \cos\left(\frac{5x + 2x}{2}\right) \cos\left(\frac{5x - 2x}{2}\right) = 0$$

$$\cos\left(\frac{7x}{2}\right) = 0 \text{ or } \cos\left(\frac{3x}{2}\right) = 0$$

$$\frac{7x}{2} = \frac{\pi}{2} + \pi k \text{ or } \frac{3x}{2} = \frac{\pi}{2} + \pi k, \text{ where } k \text{ is an integer}$$

$$x = \frac{\pi + 2\pi k}{7} \text{ or } x = \frac{\pi + 2\pi k}{3}$$

$$33. \cos(6\theta) - \cos(2\theta) = \sin(4\theta)$$

$$-2 \sin\left(\frac{6\theta + 2\theta}{2}\right) \sin\left(\frac{6\theta - 2\theta}{2}\right) = \sin(4\theta)$$

$$-2 \sin(4\theta) \sin(2\theta) - \sin(4\theta) = 0$$

$$\sin(4\theta) (-2 \sin(2\theta) - 1) = 0$$

$$\sin(4\theta) = 0 \text{ or } -2 \sin(2\theta) - 1 = 0$$

$$\sin(4\theta) = 0 \text{ or } \sin(2\theta) = -\frac{1}{2}$$

$$4\theta = \pi k \text{ or } 2\theta = \frac{7\pi}{6} + 2\pi k \text{ or } \frac{11\pi}{6} + 2\pi k$$

$$\theta = \frac{\pi k}{4} \text{ or } \frac{7\pi}{12} + \pi k \text{ or } \frac{11\pi}{12} + \pi k$$

$$35. A = \sqrt{4^2 + 6^2} = 2\sqrt{13}$$

$$\cos(c) = \frac{2}{\sqrt{13}}, \sin(c) = -\frac{3}{\sqrt{13}}$$

Since  $\sin(C)$  is negative but  $\cos(C)$  is positive, we know that  $C$  is in quadrant IV.

$$C = \sin^{-1}\left(-\frac{3}{\sqrt{13}}\right)$$

Therefore the expression can be written as  $2\sqrt{13} \sin\left(x + \sin^{-1}\left(-\frac{3}{\sqrt{13}}\right)\right)$  or approximately  $2\sqrt{13} \sin(x - 0.9828)$ .

$$37. A = \sqrt{5^2 + 2^2} = \sqrt{29}$$

$$\cos(C) = \frac{5}{\sqrt{29}}, \sin(C) = \frac{2}{\sqrt{29}}$$

Since both  $\sin(C)$  and  $\cos(C)$  are positive, we know that  $C$  is in quadrant I.

$$C = \sin^{-1}\left(\frac{2}{\sqrt{29}}\right)$$

Therefore the expression can be written as  $\sqrt{29} \sin\left(3x + \sin^{-1}\left(\frac{2}{\sqrt{29}}\right)\right)$  or approximately  $\sqrt{29} \sin(3x + 0.3805)$ .

39. This will be easier to solve if we combine the 2 trig terms into one sinusoidal function of the form  $A\sin(Bx + C)$ .

$$A = \sqrt{5^2 + 3^2} = \sqrt{34}, \quad \cos(C) = -\frac{5}{\sqrt{34}}, \quad \sin(C) = \frac{3}{\sqrt{34}}$$

C is in quadrant II, so  $C = \pi - \sin^{-1}\left(\frac{3}{\sqrt{34}}\right)$

Then:

$$\sqrt{34} \sin\left(x + \pi - \sin^{-1}\left(\frac{3}{\sqrt{34}}\right)\right) = 1$$

$$-\sin\left(x - \sin^{-1}\left(\frac{3}{\sqrt{34}}\right)\right) = \frac{1}{\sqrt{34}} \quad (\text{Since } \sin(x + \pi) = -\sin(x))$$

$$x - \sin^{-1}\left(\frac{3}{\sqrt{34}}\right) = \sin^{-1}\left(-\frac{1}{\sqrt{34}}\right) \text{ or, to get the second solution } x - \sin^{-1}\left(\frac{3}{\sqrt{34}}\right) = \pi -$$

$$\sin^{-1}\left(-\frac{1}{\sqrt{34}}\right)$$

$x \approx 0.3681$  or  $x \approx 3.8544$  are the first two solutions.

41. This will be easier to solve if we combine the 2 trig terms into one sinusoidal function of the form  $A\sin(Bx + C)$ .

$$A = \sqrt{5^2 + 3^2} = \sqrt{34}, \quad \cos(C) = \frac{3}{\sqrt{34}}, \quad \sin(C) = -\frac{5}{\sqrt{34}}$$

C is in quadrant IV, so  $C = \sin^{-1}\left(-\frac{5}{\sqrt{34}}\right)$ .

Then:

$$\sqrt{34} \sin\left(2x + \sin^{-1}\left(-\frac{5}{\sqrt{34}}\right)\right) = 3$$

$$\sin\left(2x + \sin^{-1}\left(-\frac{5}{\sqrt{34}}\right)\right) = \frac{3}{\sqrt{34}}$$

$$2x + \sin^{-1}\left(-\frac{5}{\sqrt{34}}\right) = \sin^{-1}\left(\frac{3}{\sqrt{34}}\right) \text{ and } 2x + \sin^{-1}\left(-\frac{5}{\sqrt{34}}\right) = \pi - \sin^{-1}\left(\frac{3}{\sqrt{34}}\right)$$

$$x = \frac{\sin^{-1}\left(\frac{3}{\sqrt{34}}\right) - \sin^{-1}\left(-\frac{5}{\sqrt{34}}\right)}{2} \text{ or } \frac{\pi - \sin^{-1}\left(\frac{3}{\sqrt{34}}\right) - \sin^{-1}\left(-\frac{5}{\sqrt{34}}\right)}{2}$$



$$43. \frac{\sin(7t) + \sin(5t)}{\cos(7t) + \cos(5t)} = \frac{2 \sin\left(\frac{7t+5t}{2}\right) \cos\left(\frac{7t-5t}{2}\right)}{2 \cos\left(\frac{7t+5t}{2}\right) \cos\left(\frac{7t-5t}{2}\right)} = \frac{2 \sin(6t) \cos(t)}{2 \cos(6t) \cos(t)} = \tan(6t)$$

$$45. \tan\left(\frac{\pi}{4} - t\right) = \frac{\sin\left(\frac{\pi}{4} - t\right)}{\cos\left(\frac{\pi}{4} - t\right)}$$

$$= \frac{\sin\left(\frac{\pi}{4}\right) \cos(t) - \cos\left(\frac{\pi}{4}\right) \sin(t)}{\cos\left(\frac{\pi}{4}\right) \cos(t) + \sin\left(\frac{\pi}{4}\right) \sin(t)}$$

$$= \frac{\frac{\sqrt{2}}{2}(\cos(t) - \sin(t))}{\frac{\sqrt{2}}{2}(\cos(t) + \sin(t))}$$

$$= \frac{(\cos(t))\left(1 - \frac{\sin(t)}{\cos(t)}\right)}{(\cos(t))\left(1 + \frac{\sin(t)}{\cos(t)}\right)}$$

$$= \frac{1 - \tan(t)}{1 + \tan(t)}$$

$$47. \frac{\cos(a+b)}{\cos(a-b)} = \frac{\cos(a) \cos(b) - \sin(a) \sin(b)}{\cos(a) \cos(b) + \sin(a) \sin(b)}$$

$$= \frac{\cos(a) \cos(b) \left(1 - \frac{\sin(a) \sin(b)}{\cos(a) \cos(b)}\right)}{\cos(a) \cos(b) \left(1 + \frac{\sin(a) \sin(b)}{\cos(a) \cos(b)}\right)}$$

$$= \frac{1 - \tan(a) \tan(b)}{1 + \tan(a) \tan(b)}$$

49. Using the Product-to-Sum identity:

$$2 \sin(a+b) \sin(a-b) = 2 \left(\frac{1}{2}\right) \cos((a+b) - (a-b)) - \cos((a+b) + (a-b))$$

$$= \cos(2b) - \cos(2a)$$

$$51. \frac{\cos(a+b)}{\cos(a)\cos(b)} = \frac{\cos(a) \cos(b) - \sin(a) \sin(b)}{\cos(a) \cos(b)}$$

$$= \frac{\cos(a) \cos(b)}{\cos(a) \cos(b)} - \frac{\sin(a) \sin(b)}{\cos(a) \cos(b)}$$

$$= 1 - \tan(a) \tan(b)$$

### 7.3 Solutions to Exercises

1. a.  $\sin(2x) = 2 \sin x \cos x$

To find  $\cos x$ :

$$\sin^2 x + \cos^2 x = 1$$

$$\cos^2 x = 1 - \frac{1}{64} = \frac{63}{64}$$

$\cos x = \pm \sqrt{\frac{63}{64}}$  Note that we need the positive root since we are told  $x$  is in quadrant 1.

$$\cos x = \frac{3\sqrt{7}}{8}$$

So:  $\sin(2x) = 2 \left(\frac{1}{8}\right) \left(\frac{3\sqrt{7}}{8}\right) = \frac{3\sqrt{7}}{32}$

b.  $\cos(2x) = 2 \cos^2 x - 1$

$$= 2 \left(\frac{63}{64}\right) - 1 = \frac{63 - 32}{32} = \frac{31}{32}$$

c.  $\tan(2x) = \frac{\sin(2x)}{\cos(2x)} = \frac{3\sqrt{7}/32}{31/32} = \frac{3\sqrt{7}}{31}$

3.  $\cos^2 x - \sin^2 x = \cos(2x)$ , so  $\cos^2(28^\circ) - \sin^2(28^\circ) = \cos(56^\circ)$

5.  $1 - 2 \sin^2(x) = \cos(2x)$ , so  $1 - 2 \sin^2(17^\circ) = \cos(2(17^\circ)) = \cos(34^\circ)$

7.  $\cos^2(9x) - \sin^2(9x) = \cos(2(9x)) = \cos(18x)$

9.  $4 \sin(8x) \cos(8x) = 2(2 \sin(8x) \cos(8x)) = 2 \sin(16x)$

11.  $6 \sin(2t) + 9 \sin t = 6 \cdot 2 \sin t \cos t + 9 \sin t = 3 \sin t (4 \cos t + 3)$ , so we can solve  $3 \sin t (4 \cos t + 3) = 0$ :

$$\sin t = 0 \text{ or } \cos t = -3/4$$

$t = 0, \pi$  or  $t \approx 2.4186, 3.8643$ .

$$13. 9\cos(2\theta) = 9\cos^2\theta - 4$$

$$9(\cos^2\theta - \sin^2\theta) = 9\cos^2\theta - 4$$

$$9\sin^2\theta - 4 = 0$$

$$(3\sin\theta - 2)(3\sin\theta + 2) = 0$$

$$\sin\theta = \frac{2}{3}, \frac{2}{3}$$

$$\theta = \sin^{-1}\frac{2}{3}, \sin^{-1}\frac{-2}{3}$$

$$\theta \approx 0.7297, 2.4119, 3.8713, 5.5535$$

$$15. \sin(2t) = \cos t$$

$$2\sin t \cos t = \cos t$$

$$2\sin t \cos t - \cos t = 0$$

$$\cos t (2\sin t - 1) = 0$$

$$\cos t = 0 \text{ or } 2\sin t - 1 = 0$$

If  $\cos t = 0$ , then  $t = \frac{\pi}{2}$  or  $\frac{3\pi}{2}$ . If  $2\sin t - 1 = 0$ , then  $\sin t = \frac{1}{2}$ , so  $t = \frac{\pi}{6}$  or  $\frac{5\pi}{6}$ . So  $t = \frac{\pi}{2}, \frac{3\pi}{2}, \frac{\pi}{6}$  or  $\frac{5\pi}{6}$ .

$$17. \cos(6x) - \cos(3x) = 0$$

$$2\cos^2(3x) - 1 - \cos(3x) = 0$$

$$2\cos^2(3x) - \cos(3x) - 1 = 0$$

$$(2\cos(3x) + 1)(\cos(3x) - 1) = 0$$

$$\cos(3x) = -\frac{1}{2} \text{ or } 1$$

Since we need solutions for  $x$  in the interval  $[0, 2\pi)$ , we will look for all solutions for  $3x$  in the interval  $[0, 6\pi)$ . If  $\cos(3x) = -\frac{1}{2}$ , then there are two possible sets of solutions. First,  $3x = \frac{2\pi}{3} + 2\pi k$  where  $k = 0, 1, \text{ or } 2$ , so  $x = \frac{2\pi}{9} + \frac{2\pi k}{3}$  where  $k = 0, 1, \text{ or } 2$ . Second,  $3x = \frac{4\pi}{3} + 2\pi k$  where  $k = 0, 1, \text{ or } 2$ , so  $x = \frac{4\pi}{9} + \frac{2\pi k}{3}$  where  $k = 0, 1, \text{ or } 2$ . If  $\cos(3x) = 1$ , then  $3x = 2\pi k$  where  $k = 0, 1, \text{ or } 2$ , so  $x = \frac{2\pi k}{3}$  where  $k = 0, 1, \text{ or } 2$ .

$$19. \cos^2(5x) = \frac{\cos(10x)+1}{2} \text{ because } \cos^2 x = \frac{\cos(2x)+1}{2} \text{ (power reduction identity)}$$

$$\begin{aligned}
21. \sin^4(8x) &= \sin^2(8x) \cdot \sin^2(8x) \\
&= \frac{(1-\cos(16x))}{2} \cdot \frac{(1-\cos(16x))}{2} \quad (\text{because power reduction identity } \sin^2 x = \frac{(1-\cos(2x))}{2}) \\
&= \frac{1-2\cos(16x)}{4} + \frac{\cos^2(16x)}{4} \\
&= \frac{1-2\cos(16x)}{4} + \frac{\cos(32x)+1}{8} \quad \text{because } \cos^2 x = \frac{\cos(2x)+1}{2} \text{ (power reduction identity)} \\
&= \frac{1}{4} - \frac{\cos(16x)}{2} + \frac{\cos(32x)}{8} + \frac{1}{8}
\end{aligned}$$

$$\begin{aligned}
23. \cos^2 x \sin^4 x & \\
&= \cos^2 x \cdot \sin^2 x \cdot \sin^2 x \\
&= \frac{1+\cos(2x)}{2} \cdot \frac{1-\cos(2x)}{2} \cdot \frac{1-\cos(2x)}{2} \\
&= \frac{1-\cos^2(2x)}{4} \cdot \frac{1-\cos(2x)}{2} \\
&= \frac{1-\frac{\cos(4x)+1}{2}}{4} \cdot \frac{1-\cos(2x)}{2} \\
&= \frac{1-\cos(4x)}{8} \cdot \frac{1-\cos(2x)}{2} \\
&= \frac{1-\cos(2x)-\cos(4x)+\cos(2x)\cos(4x)}{16}
\end{aligned}$$

25. Since  $\csc x = 7$  and  $x$  is in quadrant 2,  $\sin x = \frac{1}{7}$  (reciprocal of cosecant) and  $\cos x = -\frac{4\sqrt{3}}{7}$  (Pythagorean identity).

a.  $\sin\left(\frac{x}{2}\right) = \sqrt{\frac{(1-\cos(x))}{2}} = \sqrt{\frac{7+4\sqrt{3}}{14}}$  (Note that the answer is positive because  $x$  is in quadrant 2, so  $\frac{x}{2}$  is in quadrant 1.)

b.  $\cos\left(\frac{x}{2}\right) = \sqrt{\frac{(\cos x+1)}{2}} = \sqrt{\frac{7-4\sqrt{3}}{14}}$  (Note that the answer is positive because  $x$  is in quadrant 2, so  $\frac{x}{2}$  is in quadrant 1.)

c.  $\tan\left(\frac{x}{2}\right) = \frac{\sin\left(\frac{x}{2}\right)}{\cos\left(\frac{x}{2}\right)} = \sqrt{\frac{7+4\sqrt{3}}{7-4\sqrt{3}}} = \sqrt{\frac{(7+4\sqrt{3})^2}{(7-4\sqrt{3})(7+4\sqrt{3})}} = \sqrt{\frac{(7+4\sqrt{3})^2}{1}} = 7 + 4\sqrt{3}$

27.  $(\sin t - \cos t)^2 = 1 - \sin(2t)$

Left side:  $(\sin^2 t - 2 \sin t \cos t + \cos^2 t)$

$$= 1 - 2 \sin t \cos t \text{ (because } (\sin^2 t + \cos^2 t = 1))$$

$$= 1 - \sin(2t), \text{ the right side (because } \sin(2t) = 2 \sin t \cos t)$$

$$29. \sin(2x) = \frac{2 \tan(x)}{1 + \tan^2(x)}$$

$$\text{The right side: } \frac{\frac{2 \sin(x)}{\cos(x)}}{1 + \frac{\sin^2 x}{\cos^2 x}} \cdot \frac{\cos^2(x)}{\cos^2(x)} = \frac{2 \sin(x) \cos(x)}{\cos^2(x) + \sin^2(x)} = 2 \sin x \cos x = \sin(2x), \text{ the left side.}$$

$$31. \cot x - \tan x = 2 \cot(2x)$$

$$\text{The left side: } \frac{\cos(x)}{\sin(x)} - \frac{\sin(x)}{\cos(x)}$$

$$= \frac{\cos^2 x - \sin^2 x}{\sin(x) \cos(x)} = \frac{\cos(2x)}{\frac{\sin(2x)}{2}} = 2 \cot(2x)$$

$$33. \cos(2\alpha) = \frac{1 - \tan^2(\alpha)}{1 + \tan^2(\alpha)}$$

$$\text{The left side: } \frac{1 - \tan^2(\alpha)}{1 + \tan^2(\alpha)} = \frac{\frac{\cos^2 \alpha - \sin^2 \alpha}{\cos^2 \alpha}}{\frac{\cos^2 \alpha + \sin^2 \alpha}{\cos^2 \alpha}} = \frac{\cos(2\alpha)}{\frac{1}{\cos^2 \alpha}} = \cos(2\alpha)$$

$$35. \sin(3x) = 3 \sin(x) \cos^2 x - \sin^3 x$$

$$\text{Left side: } \sin(x + 2x) = \sin(x) \cos(2x) + \cos(x) \sin(2x) \text{ addition rule.}$$

$$= \sin(x) (\cos^2(x) - \sin^2(x)) + \cos(x) (2 \sin(x) \cos(x))$$

$$= \cos^2(x) \sin(x) - \sin^3(x) + 2 \cos^2(x) \sin(x)$$

$$= 3 \cos^2(x) \sin(x) - \sin^3(x)$$

## 7.4 Solutions to Exercises

1. By analysis, the function has a period of 12 units. The frequency is  $1/12$  Hz. The average of the  $y$ -values from  $0 \leq x < 12$  is  $-1$ , and since the terms repeat identically there is no change in the midline over time. Therefore the midline is  $y = f(x) = -1$ . The high point ( $y = 2$ ) and low point ( $y = -4$ ) are both 3 units away from the midline. Therefore, amplitude = 3 units. The function also starts at a minimum, which means that its phase must be shifted by one quarter of a cycle, or  $3$

units, to the right. Therefore, phase shift = 3.

Now insert known values into the function:

$$y = A \sin \left( \left( \frac{2\pi}{\text{period}} \right) (x - (\text{phase shift})) \right) + \text{midline}$$

$$y = 3 \sin \left( \frac{2\pi}{12} (x - 3) \right) - 1$$

This can be reduced to  $y = 3 \sin \left( \frac{\pi}{6} (x - 3) \right) - 1$

Alternatively, had we chosen to use the cosine function:  $y = -3 \cos \left( \frac{\pi}{6} x \right) - 1$ .

3. By analysis of the function, we determine:

$A = \text{amplitude} = 8 \text{ units}$

Solving  $\frac{2\pi}{\text{period}} = 6\pi$ , we get: period = 1/3 seconds

Frequency = 3 Hz

5. In this problem, it is assumed that population increases linearly. Using the starting average as well as the given rate, the average population is then  $y(x) = 650 + (160/12)x = 650 + (40/3)x$ , where  $x$  is measured as the number of months since January.

Based on the problem statement, we know that the period of the function must be twelve months with an amplitude of 19. Since the function starts at a low-point, we can model it with a cosine function since  $-\cos(0) = -1$

Since the period is twelve months, the factor inside the cosine operator is equal to  $\frac{2\pi}{12} = \frac{\pi}{6}$ . Thus,

the cosine function is  $-19 \cos \left( \frac{\pi}{6} x \right)$ .

Therefore, our equation is:  $y = f(x) = 650 + \frac{40}{3}x - 19 \cos \left( \frac{\pi}{6} x \right)$

7. By analysis of the problem statement, the amplitude of the sinusoidal component is 33 units with a period of 12 months. Since the sinusoidal component starts at a minimum, its phase must be shifted by one quarter of a cycle, or 3 months, to the right.

$$y = g(x) = 33 \sin \left( \frac{\pi}{6} (x - 3) \right)$$

Using the starting average as well as the given rate, the average population is then:

$$y = f(x) = 900(1.07)^x$$

$$g(x) + f(x) = 33 \sin\left(\frac{\pi}{6}(x - 3)\right) + 900(1.07)^x$$

Alternatively, if we had used the cosine function, we'd get:

$$h(x) = -33 \cos\left(\frac{\pi}{6}x\right) + 900(1.07)^x$$

9. The frequency is 18Hz, therefore period is 1/18 seconds. Starting amplitude is 10 cm. Since the amplitude decreases with time, the sinusoidal component must be multiplied by an exponential function. In this case, the amplitude decreases by 15% every second, so each new amplitude is 85% of the prior amplitude. Therefore, our equation is  $y = f(x) = 10\cos(36\pi x) \cdot (0.85)^x$ .

11. The initial amplitude is 17 cm. Frequency is 14Hz, therefore period is 1/14 seconds.

For this spring system, we will assume an exponential model with a sinusoidal factor.

The general equation looks something like this:  $D(t) = A(R)^t \cdot \cos(Bt)$  where  $A$  is amplitude,  $R$  determines how quickly the oscillation decays, and  $B$  determines how quickly the system oscillates. Since  $D(0) = 17$ , we know  $A = 17$ . Also,  $B = \frac{2\pi}{\text{period}} = 28$ .

We know  $D(3) = 13$ , so, plugging in:

$$13 = 17(R)^3 \cos(28\pi \cdot 3)$$

$$13 = 17(R)^3 \cdot 1$$

$$R^3 = \frac{13}{17}$$

$$R = \sqrt[3]{\frac{13}{17}} \approx 0.9145$$

Thus, the solution is  $D(t) = 17(0.9145)^t \cos(28\pi t)$ .

13. By analysis:

(a) must have constant amplitude with exponential growth, therefore the correct graph is IV.

(b) must have constant amplitude with linear growth, therefore the correct graph is III.

15. Since the period of this function is 4, and values of a sine function are on its midline at the endpoints and center of the period,  $f(0)$  and  $f(2)$  are both points on the midline. We'll start by looking at our function at these points:

At  $f(0)$ , plugging into the general form of the equation,  $6 = ab^0 + c\sin(0)$ , so  $a = 6$ .

At  $f(2)$ :  $96 = 6b^2 + c\sin(\pi)$ , so  $b = 4$ .

At  $f(1)$ :  $29 = 6(4)^1 + c\sin\left(\frac{\pi}{2}\right)$ . Solving gives  $c = 5$ .

This gives a solution of  $y = 6 \cdot 4^x + 5 \sin\left(\frac{\pi}{2}x\right)$ .

17. Since the period of this function is 4, and values of a sine function are on its midline at the endpoints and center of the period,  $f(0)$  and  $f(2)$  are both points on the midline.

At  $f(0)$ , plugging in gives  $7 = a\sin(0) + m + b \cdot 0$ , so  $m = 7$ .

At  $f(2)$ :  $11 = a\sin(\pi) + 7 + 2b$ . Since  $\sin(\pi) = 0$ , we get  $b = 2$ .

At  $f(1)$ :  $6 = a\sin\left(\frac{\pi}{2}\right) + 7 + 2 \cdot 1$ . Simplifying,  $a = -3$ .

This gives an equation of  $y = -3\sin\left(\frac{\pi}{2}x\right) + 2x + 7$ .

19. Since the first two places  $\cos(\theta) = 0$  are when  $\theta = \frac{\pi}{2}$  or  $\frac{3\pi}{2}$ , which for  $\cos\left(\frac{\pi}{2}x\right)$  occur when  $x = 1$  or  $x = 3$ , we'll start by looking at the function at these points:

At  $f(1)$ , plugging in gives  $3 = ab^1 \cos\left(\frac{\pi}{2}\right) + c$ . Since  $\cos\left(\frac{\pi}{2}\right) = 0$ ,  $c = 3$ . (Note that looking at  $f(3)$  would give the same result.)

At  $f(0)$ :  $11 = ab^0 \cos(0) + 3$ . Simplifying, we see  $a = 8$ .

At  $f(2)$ :  $1 = 8b^2 \cos(\pi) + 3$ . Since  $\cos(\pi) = -1$ , it follows that  $b = \frac{1}{2}$ :

$$1 = -8b^2 + 3$$

$$-8b^2 = -2$$



$$b^2 = \frac{1}{4}$$

$b = \pm \frac{1}{2}$ , but since we require exponential expressions to have a positive number as the base,

$b = \frac{1}{2}$ . Therefore, the final equation is:  $y = 8 \left(\frac{1}{2}\right)^x \cos\left(\frac{\pi}{2}x\right) + 3$ .

## 8.1 Solutions to Exercises

1. Since the sum of all angles in a triangle is  $180^\circ$ ,  $180^\circ = 70^\circ + 50^\circ + \alpha$ . Thus  $\alpha = 60^\circ$ .

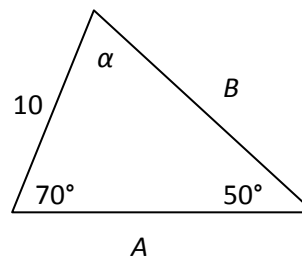

The easiest way to find  $A$  and  $B$  is to use Law of Sines.

According to Law of Sines,  $\frac{\sin(\alpha)}{a} = \frac{\sin(\beta)}{b} = \frac{\sin(\gamma)}{c}$ , where each angle is across from its respective side.

Thus,  $\frac{\sin(60)}{A} = \frac{\sin(70)}{B} = \frac{\sin(50)}{10}$ . Then  $B = \frac{10 \sin(70)}{\sin(50)} \approx 12.26$ , and  $A = \frac{10 \sin(60)}{\sin(50)} \approx 11.31$ .

3. Since the sum of all angles in a triangle is  $180^\circ$ ,  $180^\circ = 25^\circ + 120^\circ + \alpha$ . Thus  $\alpha = 35^\circ$ . The easiest way to find  $C$  and  $B$  is to use Law of Sines. According to Law of Sines,

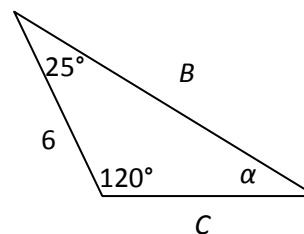

$\frac{\sin(\alpha)}{a} = \frac{\sin(\beta)}{b} = \frac{\sin(\gamma)}{c}$ , where each angle is across from its

respective side. Thus,  $\frac{\sin(35)}{6} = \frac{\sin(120)}{B} = \frac{\sin(25)}{C}$ . Then  $B = \frac{6 \sin(120)}{\sin(35)} \approx 9.06$ , and  $C =$

$$\frac{6 \sin(25)}{\sin(35)} \approx 4.42.$$

5. According to Law of Sines,  $\frac{\sin(\alpha)}{a} = \frac{\sin(\beta)}{b} = \frac{\sin(\gamma)}{c}$ , where each

angle is across from its respective side. Thus,

$$\frac{\sin(\alpha)}{A} = \frac{\sin(\beta)}{5} = \frac{\sin(65)}{6}. \text{ Thus } \frac{\sin(\beta)}{5} = \frac{\sin(65)}{6} \text{ and } \beta =$$

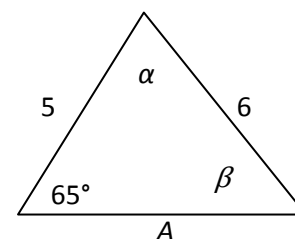

$\sin^{-1}\left(\frac{5 \sin(65)}{6}\right) \approx 49.05^\circ$ . Recall there are two possible solutions from  $0$  to  $2\pi$ ; to find the other solution use symmetry.  $\beta$  could also be  $180 - 49.05 = 130.95$ . However, when this and the given side are added together, their sum is greater than  $180$ , so  $130.95$  cannot be  $\beta$ . Since the sum of all angles in a triangle is  $180^\circ$ ,  $180^\circ = 49.05^\circ + 65^\circ + \alpha$ . Thus  $\alpha = 65.95^\circ$ .

Again from Law of Sines  $\frac{\sin(65.95)}{A} = \frac{\sin(49.05)}{5}$ , so  $A = \frac{5\sin(65.95)}{\sin(49.05)} \approx 6.05$ .

7. According to Law of Sines,  $\frac{\sin(\alpha)}{a} = \frac{\sin(\beta)}{b} = \frac{\sin(\gamma)}{c}$ ,

where each angle is across from its respective side. Thus,

$$\frac{\sin(\alpha)}{A} = \frac{\sin(\beta)}{5} = \frac{\sin(65)}{6}. \text{ Thus } \frac{\sin(\beta)}{25} = \frac{\sin(40)}{18} \text{ and}$$

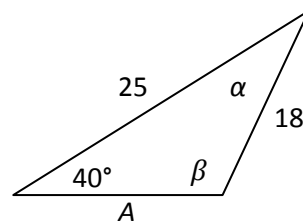

$\beta = \sin^{-1}\left(\frac{25\sin(40)}{18}\right) \approx 63.33^\circ$ . Whenever solving for angles with the Law of Sines there are two possible solutions. Using symmetry the other solution may be  $180-63.33=116.67$ . However, the triangle shown has an obtuse angle  $\beta$  so  $\beta=116.67^\circ$ . Since the sum of all angles in a triangle is  $180^\circ$ ,  $180^\circ=116.78^\circ+40^\circ +\alpha$ . Thus  $\alpha = 23.22^\circ$ .

Again from Law of Sines  $\frac{\sin(23.22)}{A} = \frac{\sin(40)}{18}$ , so  $A = \frac{18\sin(23.22)}{\sin(40)} \approx 11.042$ .

9. Since the sum of all angles in a triangle is  $180^\circ$ ,  $180^\circ=69^\circ+43^\circ +\beta$ . Thus  $\beta = 68^\circ$ . Using Law of

Sines,  $\frac{\sin(43)}{a} = \frac{\sin(68)}{20} = \frac{\sin(69)}{c}$ , so  $a = \frac{20\sin(43)}{\sin(68)} \approx 14.71$  and  $c = \frac{20\sin(69)}{\sin(68)} \approx 20.13$ .

Once two sides are found the third side can be found using Law of Cosines. If side  $c$  is found first then side  $a$  can be found using,  $a^2 = c^2 + b^2 - 2bccos(\alpha) = 20.13^2 + 20^2 - 2(20)(20.13) \cos(43)$

11. To find the second angle, Law of Sines must be used. According to Law of Sines

$\frac{\sin(119)}{26} = \frac{\sin(\beta)}{14}$ , so  $\beta = \sin^{-1}\left(\frac{14}{26}\sin(119)\right) \approx 28.10$ . Whenever the inverse sine function is

used there are two solutions. Using symmetry the other solution could be  $180-20.1=159.9$ , but since that number added to our given angle is more than 180, that is not a possible solution.

Since the sum of all angles in a triangle is  $180^\circ$ ,  $180^\circ=119^\circ+28.10^\circ +\gamma$ . Thus  $\gamma = 32.90^\circ$ . To find the last side either Law of Sines or Law of Cosines can be used. Using Law of Sines,

$\frac{\sin(119)}{26} = \frac{\sin(28.10)}{14} = \frac{\sin(32.90)}{c}$ , so  $c = \frac{14\sin(32.90)}{\sin(28.10)} = \frac{26\sin(32.90)}{\sin(119)} \approx 16.15$ . Using Law of

Cosines,  $c^2 = a^2 + b^2 - 2abcos(\gamma) = 26^2 + 14^2 - 2(26)(14) \cos(32.90)$  so  $c \approx 16.15$ .

13. To find the second angle, Law of Sines must be used. According to Law of Sines,

$$\frac{\sin(50)}{45} = \frac{\sin(\alpha)}{105}. \text{ However, when solved the quantity inside the inverse sine is greater than 1,}$$

which is out of the range of sine, and therefore out of the domain of inverse sine, so it cannot be solved.

15. To find the second angle Law of Sines must be used. According to Law of Sines,

$$\frac{\sin(43.1)}{184.2} = \frac{\sin(\beta)}{242.8}, \text{ so } \beta = \sin^{-1}\left(\frac{242.8}{184.2}\sin(43.1)\right) \approx 64.24 \text{ or } \beta = 180 - 64.24 = 115.76.$$

Since the sum of all angles in a triangle is  $180^\circ$ ,  $180^\circ = 43.1^\circ + 64.24^\circ + \gamma$  or

$180^\circ = 43.1^\circ + 115.76^\circ + \gamma$ . Thus  $\gamma = 72.66^\circ$  or  $\gamma = 21.14^\circ$ . To find the last side either Law of Sines

or Law of Cosines can be used. Using Law of Sines,  $\frac{\sin(43.1)}{184.2} = \frac{\sin(64.24)}{242.8} = \frac{\sin(72.66)}{c}$ ,

$$\text{so } c = \frac{184.2\sin(72.66)}{\sin(43.1)} = \frac{242.8\sin(72.66)}{\sin(64.24)} \approx 257.33. \text{ The same procedure can be used to find the}$$

alternate solution where  $c = 97.238$ .

Using Law of Cosines,

$$c^2 = a^2 + b^2 - 2ab\cos(\gamma) = 184.2^2 + 242.8^2 - 2(184.2)(242.8)\cos(72.66) \text{ so } c \approx 257.33.$$

17. Because the givens are an angle and the two sides around it, it is best to use Law of Cosines to find the third side. According to Law of Cosines,  $a^2 = c^2 + b^2 - 2bccos(\alpha) = 20^2 + 28^2 - 2(20)(28)\cos(60)$ , so  $A \approx 24.98$ .

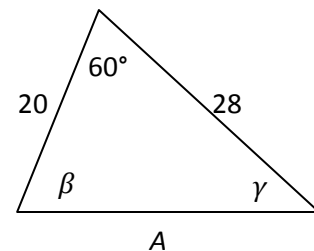

Using Law of Sines,  $\frac{\sin(60)}{24.98} = \frac{\sin(\beta)}{28} = \frac{\sin(\gamma)}{20}$ , so  $\beta =$

$\sin^{-1}\left(\frac{28}{24.98}\sin(60)\right) \approx 76.10$ . Because the angle  $\beta$  in the picture is acute, it is not necessary to find the second solution. The sum of the angles in a triangle is  $180^\circ$  so  $180^\circ = 76.10^\circ + 60^\circ + \gamma$  and  $\gamma = 43.90^\circ$ .

19. In this triangle only sides are given, so Law of Sines cannot be used. According to Law of Cosines:

$$a^2 = c^2 + b^2 - 2bc \cos(\alpha) \text{ so } 11^2 = 13^2 + 20^2 - 2(13)(20) \cos(\alpha). \text{ Then } \alpha = \cos^{-1} \left( \frac{13^2 + 20^2 - 11^2}{2(13)(20)} \right) \approx 30.51.$$

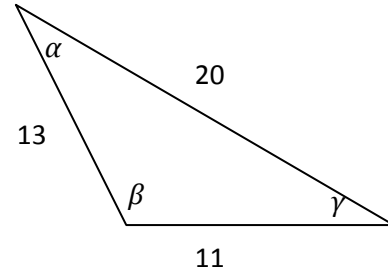

To find the next sides Law of Cosines or Law of Sines can be used. Using Law of Cosines,

$$b^2 = c^2 + a^2 - 2accos(\beta) \Rightarrow 20^2 = 13^2 + 11^2 - 2(13)(11) \cos(\beta) \text{ so}$$

$$\beta = \cos^{-1} \left( \frac{13^2 + 11^2 - 20^2}{2(13)(11)} \right) \approx 112.62.$$

The sum of the angles in a triangle is 180 so  $180^\circ = 112.62^\circ + 30.51^\circ + \gamma$  and  $\gamma = 36.87^\circ$ .

21. Because the angle corresponds to neither of the given sides it is easiest to first use Law of Cosines to find the third side. According to Law of Cosines,  $c^2 = a^2 + b^2 - 2abc \cos(\gamma) = 2.49^2 + 3.13^2 - 2(2.49)(3.13) \cos(41.2)$ , so  $c = 2.07$ .

To find the  $\alpha$  or  $\beta$  either Law of Cosines or Law of Sines can be used. Using Law of Sines,  $\frac{\sin(41.2)}{2.07} = \frac{\sin(\alpha)}{2.49}$ , so  $\alpha = \sin^{-1} \left( \frac{2.49 \sin(41.2)}{2.07} \right) \approx 52.55^\circ$ . The inverse sine function gives two solutions so  $\alpha$  could also be  $180 - 52.55 = 127.45$ . However, side  $b$  is larger than side  $c$  so angle  $\gamma$  must be smaller than  $\beta$ , which could not be true if  $\alpha = 127.45$ , so  $\alpha = 52.55$ . The sum of angles in a triangle is  $180^\circ$ , so  $180^\circ = 52.55 + 41.2 + \beta$  and  $\beta = 86.26^\circ$ .

23. Because the angle corresponds to neither of the given sides it is easiest to first use Law of Cosines to find the third side. According to Law of Cosines,  $a^2 = c^2 + b^2 - 2cbc \cos(\alpha) = 7^2 + 6^2 - 2(7)(6) \cos(120)$ , so  $a = 11.27$ .

Either Law of Cosines or Law of Sines can be used to find  $\beta$  and  $\gamma$ . Using Law of Cosines,

$$b^2 = c^2 + a^2 - 2accos(\beta) \Rightarrow 6^2 = 7^2 + 11.27^2 - 2(7)(11.27) \cos(\beta), \text{ so}$$

$$\beta = \cos^{-1} \left( \frac{7^2 + 11.27^2 - 6^2}{2(7)(11.27)} \right) \approx 27.46. \text{ The sum of all the angles in a triangle is } 180^\circ \text{ so}$$

$$180^\circ = 27.46^\circ + 120^\circ + \gamma, \text{ and } \gamma = 32.54^\circ.$$

This material was created by Shoreline Community College and edited by Rosalie Tepper. This material is licensed under a Creative Commons NonCommercial-ShareAlike license.

25. The equation of the area of a triangle is  $A = \frac{1}{2}bh$ . It is important to draw a picture of the triangle to figure out which angles and sides need to be found.

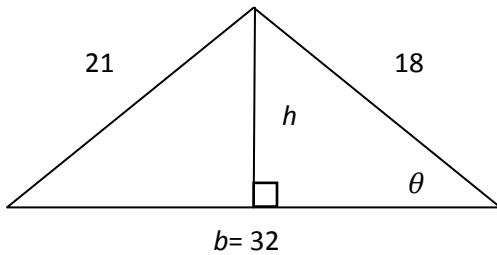

With the orientation chosen the base is 32. Because the height makes a right triangle inside of the original triangle, all that needs to be found is one angle to find the height, using trig. Either side of the triangle can be used.

According to Law of Cosines  $21^2 = 18^2 + 32^2 - 2(18)(32)\cos(\theta)$

so,  $\theta = \cos^{-1}\left(\frac{18^2+32^2-21^2}{2(18)(32)}\right) \approx 38.06$ . Using this angle,  $h = \sin(38.06)18 \approx 11.10$ , so  $A =$

$$\frac{32 \cdot 11.10}{2} \approx 177.56.$$

27. Because the angle corresponds to neither of the given it is easiest to first use Law of Cosines, to find the third side.

According to Law of Cosines  $d^2 = 800^2 + 900^2 - 2(800)(900)\cos(70)$  where  $d$  is the distance across the lake.  $d = 978.51\text{ft}$

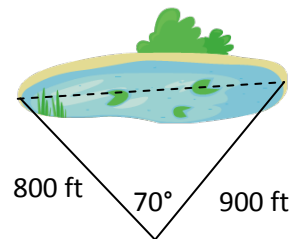

sides

29. To completely understand the situation it is important first draw a new triangle, where  $d_s$  is the distance from the boat to the shore and  $d_A$  is the distance from station A to the

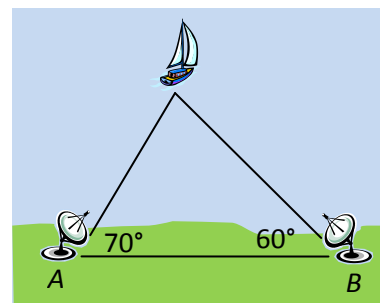
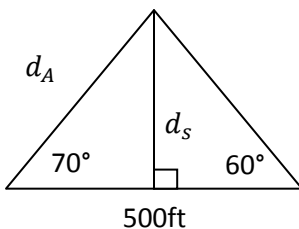

to  
boat  
boat.

Since the only side length given does not have a corresponding angle given, the corresponding angle ( $\theta$ ) must first be found. The sum of all angles in a triangle must be  $180^\circ$ , so  $180^\circ = 70^\circ + 60^\circ + \theta$ , and  $\theta = 50^\circ$ .

Knowing this angle allows us to use Law of Sines to find  $d_A$ . According to Law of Sines

$$\frac{\sin(50)}{500} = \frac{\sin(60)}{d_A} \Rightarrow d_A = \frac{500\sin(60)}{\sin(50)} \approx 565.26ft.$$

To find  $d_s$ , trigonometry of the left hand right triangle can be used.  $d_s = \sin(70)565.26ft \approx 531.17ft$ .

31. The hill can be visualized as a right triangle below the triangle that the wire makes, assuming a line perpendicular to the base of  $67^\circ$  angle is dropped from the top of the tower. Let  $L$  be the length of the guy wire.

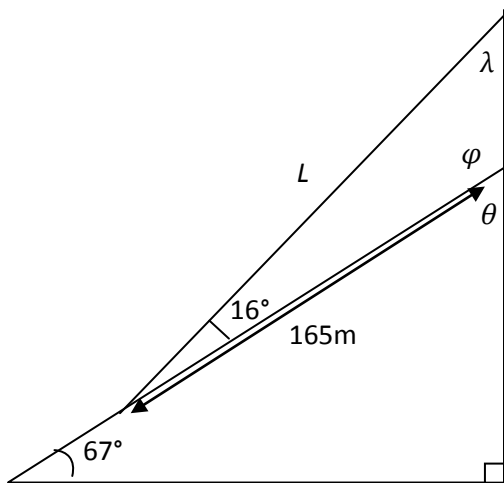
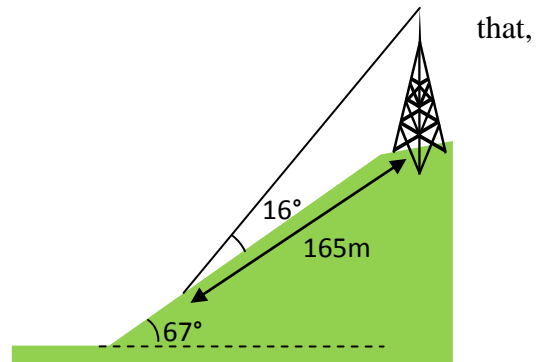

In order to find  $L$  using Law of Cosines, the height of the tower, and the angle between the tower and the hill need to be found.

To solve using Law of Sines only the angle between the guy wire and the tower, and the angle corresponding with  $L$  need to be found.

Since finding the angles requires only basic triangle relationships, solving with Law of Sines will be the simpler solution.

The sum of all angles in a triangle is  $180^\circ$ , this rule can be used to find the angle of the hill at the tower location ( $\theta$ ).  $180^\circ = 90^\circ + 67^\circ + \theta$ , so  $\theta = 23^\circ$ .

$\theta$  and the angle between the tower and the hill ( $\varphi$ ) are supplementary angles, so  $\theta + \varphi = 180^\circ$ , thus  $\varphi = 157^\circ$ .

Using once again the sum of all angles in a triangle,  $\varphi + 16 + \lambda = 180$ , so  $\lambda = 7^\circ$ .

According to Law of Sines,  $\frac{\sin(7)}{165} = \frac{\sin(157)}{L}$ , so  $L = \frac{165\sin(157)}{\sin(7)} \approx 529.01 \text{ m}$ .

33. Let  $L$  be the length of the wire.

The hill can be visualized as a right triangle, assuming that a line perpendicular to the base of the  $38^\circ$  angle is dropped from the top of the tower.

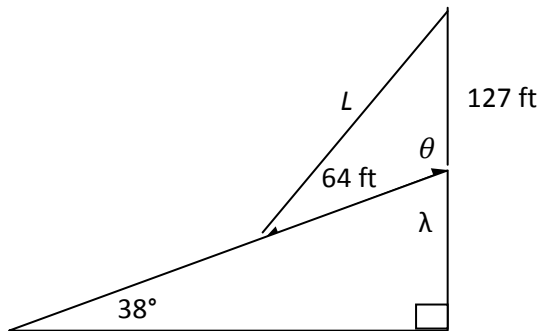
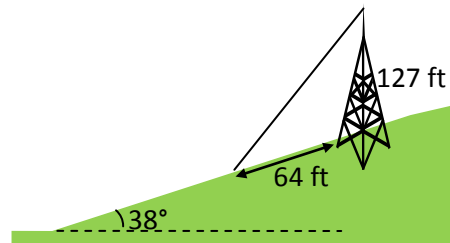

Because two sides of the triangle are given, and the last side is what is asked for, it is best to use Law of Cosines. In order to use Law of Cosines, the angle  $\theta$  corresponding to  $L$  needs to be found. In order to find  $\theta$  the last angle in the right triangle ( $\lambda$ ) needs to be found.

The sum of all angles in a triangle is  $180^\circ$ , so  $180^\circ = 38^\circ + 90^\circ + \lambda$ , and  $\lambda = 52^\circ$ .  $\lambda$  and  $\theta$  are supplementary angles so  $\lambda + \theta = 180^\circ$ , and  $\theta = 128^\circ$ .

According to Law of Cosines,  $L^2 = 127^2 + 64^2 - 2(127)(64) \cos(128)$ , so  $L = 173.88 \text{ ft}$ .



35. Using the relationship between alternate interior angles, the angle at A inside the triangle is  $37^\circ$ , and the angle at B inside the triangle is  $44^\circ$ .

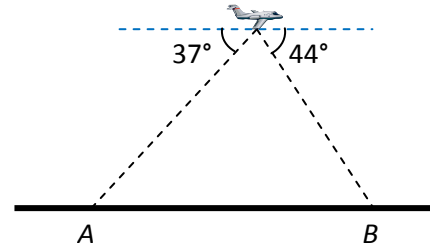
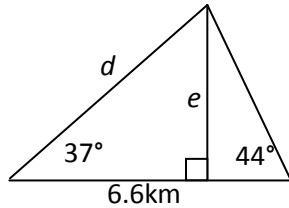

Let  $e$  be the elevation of the plane, and let  $d$  be the distance from the plane to point A. To find the last angle ( $\theta$ ), use the sum of angles.  $180^\circ = 37^\circ + 44^\circ + \theta$ , so  $\theta = 99^\circ$ .

Because there is only one side given, it is best to use Law of Sines to solve for  $d$ . According to Law of Sines,  $\frac{\sin(44)}{d} = \frac{\sin(99)}{6.6}$ , so  $d = \frac{6.6\sin(44)}{\sin(99)} \approx 4.64$  km.

Using the right triangle created by drawing  $e$  and trigonometry of that triangle,  $e$  can be found.  $e = 4.64 \sin(37) \approx 2.79$  km.

37. Assuming the building is perpendicular with the ground, this situation can be drawn as two triangles.

Let  $h$  = the height of the building. Let  $x$  = the distance from the first measurement to the top of the building.

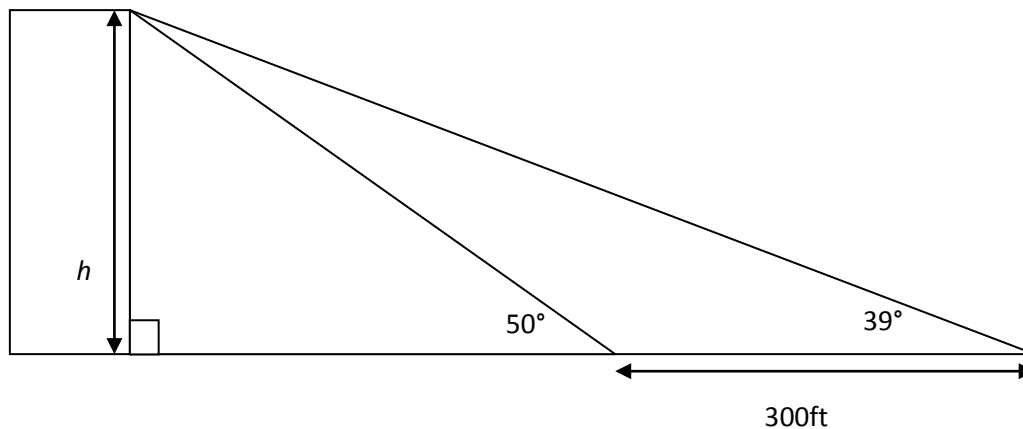

In order to find  $h$ , we need to first know the length of one of the other sides of the triangle.  $x$  can be found using Law of Sines and the triangle on the right.

The angle that is adjacent to the angle measuring  $50^\circ$  has a measure of  $130^\circ$ , because it is supplementary to the  $50^\circ$  angle. The angle of the top of the right hand triangle measures  $11^\circ$  since all the angles in the triangle have a sum of  $180^\circ$ .

According to Law of Sines,  $\frac{\sin(39)}{x} = \frac{\sin(11)}{300ft}$ , so  $x = 989.45ft$ .

Finding the value of  $h$  only requires trigonometry.  $h = (989.45 ft)\sin(50) \approx 757.96 ft$ .

39. Because the given information tells us two sides and information relating to the angle opposite the side we need to find, Law of Cosines must be used.

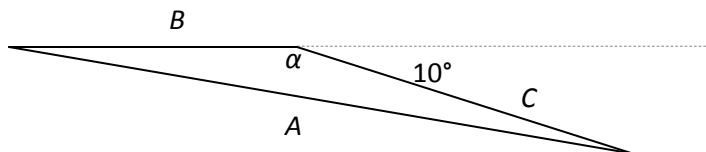

The angle  $\alpha$  is supplementary with the  $10^\circ$  angle, so  $\alpha = 180^\circ - 10^\circ = 170^\circ$ .

From the given information, the side lengths can be found:

$$B = 1.5 \text{ hours} \cdot \frac{680 \text{ miles}}{1 \text{ hour}} = 1020 \text{ miles.}$$

$$C = 2 \text{ hours} \cdot \frac{680 \text{ miles}}{1 \text{ hour}} = 1360 \text{ miles.}$$

According to Law of Cosines: so  $A^2 = (1020)^2 + (1360)^2 - 2(1020)(1360) \cos(170)$ .

Solving for  $A$  gives  $A \approx 2,371.13$  miles.

41. Visualized, the shape described looks like:

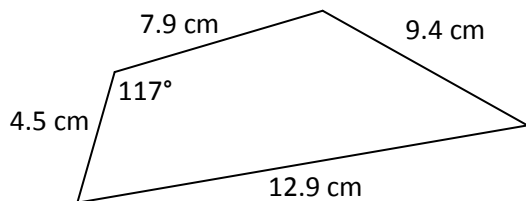

Drawing a line from the top right corner to the bottom left corner breaks the shape into two triangles. Let  $L$  be the length of the new line.

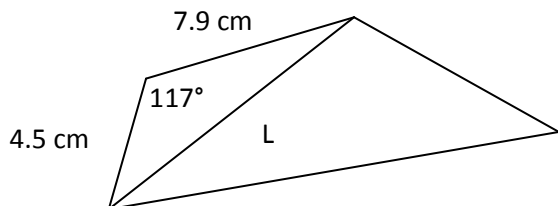

Because the givens are two sides and one angle, Law of Cosines can be used to find length  $L$ .

$$L^2 = 4.5^2 + 7.9^2 - 2(4.5)(7.9)\cos(117^\circ) \quad L = 10.72$$

The equation for the area of a triangle is  $A = \frac{1}{2}bh$ . To find the area of the quadrilateral, it can be broken into two separate triangles, with their areas added together.

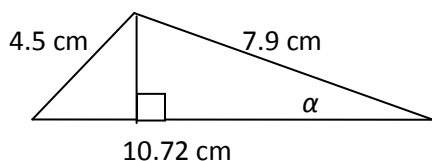

In order to use trig to find the area of the first triangle, one of the angles adjacent to the base must be found, because that angle will be the angle used in the right triangle to find the height of the right triangle ( $h$ ).

According to Law of Cosines  $4.5^2 = 10.72^2 + 7.9^2 - 2(10.72)(7.9)\cos(\alpha)$ , so  $\alpha \approx 21.97^\circ$ .

Using trigonometry,  $h = 7.9\sin(21.97) \approx 2.96$  cm. So,  $A_1 = \frac{(2.96\text{cm})(10.72\text{cm})}{2} \approx 15.84$   $\text{cm}^2$ .

The same procedure can be used to evaluate the Area of the second triangle.

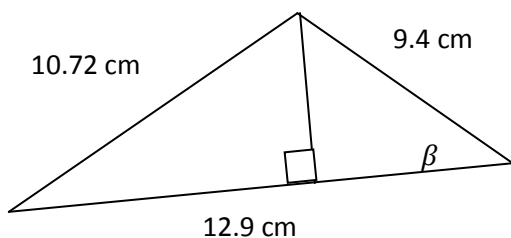

According to Law of Cosines  $10.72^2 = 9.4^2 + 12.9^2 - 2(9.4)(12.9)\cos(\beta)$ , so  $\beta \approx 54.78^\circ$ .

Using trigonometry,  $h = 9.4\sin(54.78) \approx 7.68$  cm.

$$\text{So, } A_2 = \frac{(7.68\text{cm})(12.9\text{cm})}{2} \approx 49.53 \text{ cm}^2.$$

The area of the quadrilateral is the sum of the two triangle areas so,  $A_q = 49.53 + 15.84 = 65.37 \text{ cm}^2$ .

41. If all the centers of the circles are connected a triangle forms whose sides can be found using the radii of the circles.

Let side  $A$  be the side formed from the 6 and 7 radii connected. Let side  $B$  be the side formed from the 6 and 8 radii connected. Let side  $C$  be the side formed by the 7 and 8 radii connected.

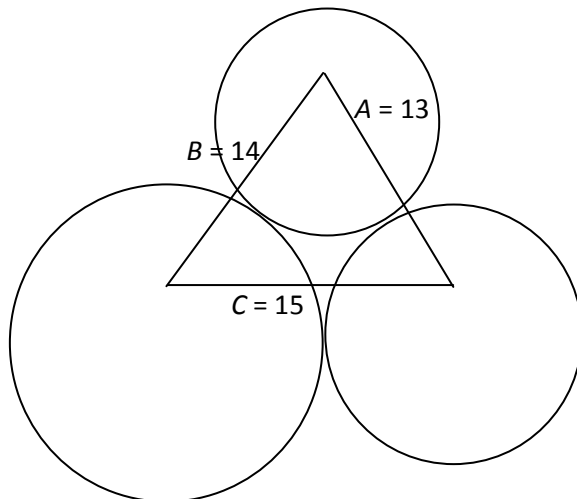

In order to find the area of the shaded region we must first find the area of the triangle and the areas of the three circle sections and find their difference.

To find the area of the triangle the height must be found using trigonometry and an angle found using Law of Cosines

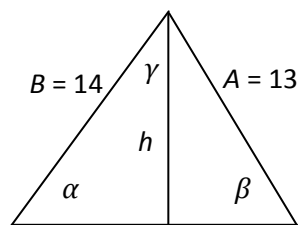

Base =  $C = 15$

This material was created by Shoreline Community College and edited by Rosalie Tepper. This material is licensed under a Creative Commons NonCommercial-ShareAlike license.

According to Law of Cosines,  $13^2 = 14^2 + 15^2 - 2(14)(15) \cos(\alpha)$ , so  $\alpha \approx 53.13^\circ$ .

Using trigonometry  $h = 14 \sin(53.13^\circ) = 11.2$ , so  $A_T = \frac{(11.2)(15)}{2} = 84$ .

To find the areas of the circle sections, first find the areas of the whole circles. The three areas are,  $A_6 = \pi(6)^2 \approx 113.10$ ,  $A_7 = \pi(7)^2 \approx 153.94$ , and  $A_8 = \pi(8)^2 \approx 201.06$ .

To find the Area of the portion of the circle, set up an equation involving ratios.

$$\frac{\text{Section Area } (A_s)}{\text{Circle Area } (A_c)} = \frac{\text{Section angle } (D_s)}{\text{Circle Angle } (360)} \Rightarrow A_s = (A_c) \frac{D_s}{360}$$

The section angles can be found using the original triangle and Law of Cosines.

$$14^2 = 13^2 + 15^2 - 2(13)(15)\cos(\beta), \text{ so } \beta \approx 59.49^\circ.$$

The sum of all angles in a triangle has to equal  $180^\circ$ , so  $180^\circ = \alpha + \beta + \gamma = 59.49^\circ + 53.13^\circ + \gamma$ , so,  $\gamma = 67.38^\circ$ .

Using this information,  $A_{s6} = \frac{(67.38)(113.10)}{360} \approx 21.17$ ,  $A_{s7} = \frac{(59.49)(153.94)}{360} \approx 25.44$ ,  $A_{s8} = \frac{(53.13)(201.06)}{360} \approx 29.67$ . So, the area of the shaded region  $A_f = A_T - A_{s6} - A_{s7} - A_{s8} = 84 - 21.17 - 25.44 - 29.67 = 7.72$ .

## 8.2 Solutions to Exercises

1. The Cartesian coordinates are  $(x, y) = (r \cos(\theta), r \sin(\theta))$

$$= \left( 7 \cos\left(\frac{7\pi}{6}\right), 7 \sin\left(\frac{7\pi}{6}\right) \right) = \left( -7 \cos\left(\frac{\pi}{6}\right), -7 \sin\left(\frac{\pi}{6}\right) \right) = \left( -\frac{7\sqrt{3}}{2}, -\frac{7}{2} \right)$$

3. The Cartesian coordinates are  $(x, y) = (r \cos(\theta), r \sin(\theta))$

$$= \left( 4 \cos\left(\frac{7\pi}{4}\right), 4 \sin\left(\frac{7\pi}{4}\right) \right) = \left( 4 \cos\left(\frac{\pi}{4}\right), -4 \sin\left(\frac{\pi}{4}\right) \right) = \left( \frac{4\sqrt{2}}{2}, -\frac{4\sqrt{2}}{2} \right) = (2\sqrt{2}, -2\sqrt{2})$$

This material was created by Shoreline Community College and edited by Rosalie Tepper. This material is licensed under a Creative Commons NonCommercial-ShareAlike license.

5. The Cartesian coordinates are  $(x, y) = (r \cos(\theta), r \sin(\theta))$

$$= \left(6 \cos\left(-\frac{\pi}{4}\right), 6 \sin\left(-\frac{\pi}{4}\right)\right) = \left(6 \cos\left(\frac{\pi}{4}\right), -6 \sin\left(\frac{\pi}{4}\right)\right) = \left(\frac{6\sqrt{2}}{2}, -\frac{6\sqrt{2}}{2}\right) = (3\sqrt{2}, -3\sqrt{2})$$

7. The Cartesian coordinates are  $(x, y) = (r \cos(\theta), r \sin(\theta)) = \left(3 \cos\left(\frac{\pi}{2}\right), 3 \sin\left(\frac{\pi}{2}\right)\right) = (0, 3)$

9. The Cartesian coordinates are  $(x, y) = (r \cos(\theta), r \sin(\theta)) = \left(-3 \cos\left(\frac{\pi}{6}\right), -3 \sin\left(\frac{\pi}{6}\right)\right) = \left(-\frac{3\sqrt{3}}{2}, -\frac{3}{2}\right)$

11. The Cartesian coordinates are  $(x, y) = (r \cos(\theta), r \sin(\theta)) = (3 \cos(2), 3 \sin(2)) \approx (-1.2484, 2.7279)$

13.  $(4, 2) = (x, y) = (r \cos(\theta), r \sin(\theta))$ . Then  $\tan(\theta) = \frac{y}{x} = \frac{2}{4} = \frac{1}{2}$ . Since  $(x, y)$  is located in the first quadrant, where  $0 \leq \theta \leq \frac{\pi}{2}$ ,  $\theta = \tan^{-1}\left(\frac{1}{2}\right) \approx 0.46365$ . And  $r^2 = x^2 + y^2 = 4^2 + 2^2 = 20 \rightarrow r = \sqrt{20} = 2\sqrt{5}$ .

15.  $(-4, 6) = (x, y) = (r \cos(\theta), r \sin(\theta))$ . Then  $\tan(\theta) = \frac{y}{x} = \frac{6}{-4} = -\frac{3}{2}$ . Since  $(x, y)$  is located in the second quadrant, where  $\frac{\pi}{2} \leq \theta \leq \pi$ , and  $\tan(\theta) = \tan(\theta + \pi)$ ,  $\theta = \tan^{-1}\left(-\frac{3}{2}\right) + \pi \approx -0.9828 + \pi \approx 2.1588$ . And  $r^2 = x^2 + y^2 = (-4)^2 + 6^2 = 52 \rightarrow r = 2\sqrt{13}$ .

17.  $(3, -5) = (x, y) = (r \cos(\theta), r \sin(\theta))$ . Then  $\tan(\theta) = \frac{y}{x} = \frac{-5}{3}$ . Since  $(x, y)$  is located in the fourth quadrant, where  $\frac{3\pi}{2} \leq \theta \leq 2\pi$ ,  $\theta = \tan^{-1}\left(-\frac{5}{3}\right) + 2\pi \approx -1.0304 + 2\pi \approx 5.2528$ . And  $r^2 = x^2 + y^2 = 3^2 + (-5)^2 = 34 \rightarrow r = \sqrt{34}$ .

19.  $(-10, -13) = (x, y) = (r \cos(\theta), r \sin(\theta))$ . Then  $\tan(\theta) = \frac{y}{x} = \frac{-13}{-10} = \frac{13}{10}$ . Since  $(x, y)$  is located in the third quadrant, where  $\pi \leq \theta \leq \frac{3\pi}{2}$ , and  $\tan(\theta) = \tan(\theta + \pi)$ ,  $\theta = \tan^{-1}\left(\frac{13}{10}\right) + \pi \approx 0.9151 + \pi \approx 4.0567$ . And  $r^2 = x^2 + y^2 = (-10)^2 + (-13)^2 = 269 \rightarrow r = \sqrt{269}$ .

21.  $x = 3 \rightarrow r \cos(\theta) = 3$  or  $r = \frac{3}{\cos(\theta)} = 3 \sec(\theta)$ .

$$23. y = 4x^2 \rightarrow r \sin(\theta) = 4 [r \cos(\theta)]^2 = 4 r^2 \cos^2(\theta)$$

$$\text{Then } \sin(\theta) = 4r \cos^2(\theta), \text{ so } r = \frac{\sin(\theta)}{4 \cos^2(\theta)} = \frac{\tan(\theta) \sec(\theta)}{4}.$$

$$25. x^2 + y^2 = 4y \rightarrow r^2 = 4r \sin(\theta). \text{ Then } r = 4 \sin(\theta).$$

$$27. x^2 - y^2 = x \rightarrow [r \cos(\theta)]^2 - [r \sin(\theta)]^2 = r \cos(\theta). \text{ Then:}$$

$$r^2 [\cos^2(\theta) - \sin^2(\theta)] = r \cos(\theta)$$

$$r [\cos^2(\theta) - \sin^2(\theta)] = \cos(\theta)$$

$$r = \frac{\cos(\theta)}{\cos^2(\theta) - \sin^2(\theta)}.$$

$$29. r = 3 \sin(\theta) \rightarrow r^2 = 3r \sin(\theta) \rightarrow x^2 + y^2 = 3y.$$

$$31. r = \frac{4}{\sin(\theta) + 7 \cos(\theta)} \rightarrow r \sin(\theta) + 7r \cos(\theta) = 4 \rightarrow y + 7x = 4.$$

$$33. r = 2 \sec(\theta) = \frac{2}{\cos(\theta)} \rightarrow r \cos(\theta) = 2 \rightarrow x = 2.$$

$$35. r = \sqrt{r \cos(\theta) + 2} \rightarrow r^2 = r \cos(\theta) + 2 \rightarrow x^2 + y^2 = x + 2.$$

37. We can choose values of  $\theta$  to plug in to find points on the graph, and then see which of the given graphs contains those points.

$$\theta = 0 \rightarrow r = 2 + 2 \cos(0) = 4$$

$$\theta = \pi \rightarrow r = 2 + 2 \cos(\pi) = 0$$

$$\theta = \frac{\pi}{2} \rightarrow r = 2 + 2 \cos\left(\frac{\pi}{2}\right) = 2$$

$$\theta = \frac{3\pi}{2} \rightarrow r = 2 + 2 \cos\left(\frac{3\pi}{2}\right) = 2$$

So the matching graph should be A.

39. We can choose values of  $\theta$  to plug in to find points on the graph, and then see which of the given graphs contains those points.

$$\theta = 0 \rightarrow r = 4 + 3 \cos(0) = 7$$

$$\theta = \pi \rightarrow r = 4 + 3 \cos(\pi) = 1$$

$$\theta = \frac{\pi}{2} \rightarrow r = 4 + 3 \cos\left(\frac{\pi}{2}\right) = 4$$

$$\theta = \frac{3\pi}{2} \rightarrow r = 4 + 3 \cos\left(\frac{3\pi}{2}\right) = 4$$

So the matching graph should be C.

41.  $r = 5$  means that we're looking for the graph showing all points that are 5 units from the origin, so the matching graph should be E. To verify this using the Cartesian equation:  $r = 5 \rightarrow r^2 = 25 \rightarrow x^2 + y^2 = 25$ , which is the equation of the circle centered at the origin with radius 5.

43. We can choose values of  $\theta$  to plug in to find points on the graph.

$$\theta = \frac{\pi}{2} \rightarrow r = \log\left(\frac{\pi}{2}\right) \approx 0.1961$$

$$\theta = \pi \rightarrow r = \log(\pi) \approx 0.4971$$

$$\theta = \frac{3\pi}{2} \rightarrow r = \log\left(\frac{3\pi}{2}\right) \approx 0.6732, \text{ and so on.}$$

Observe that as  $\theta$  increases its value, so does  $r$ . Therefore the matching graph should be C.

45. We can make a table of values of points satisfying the equation to see which of the given graphs contains those points.

$\theta$	0	$\frac{\pi}{2}$	$\pi$	$\frac{3\pi}{2}$	$2\pi$	$\frac{5\pi}{2}$	$3\pi$	$\frac{7\pi}{2}$
$r$	1	$\frac{\sqrt{2}}{2}$	0	$\frac{\sqrt{2}}{2}$	-1	$\frac{\sqrt{2}}{2}$	0	$\frac{\sqrt{2}}{2}$

So the matching graph should be D.

47. We can make a table of values of points satisfying the equation to see which of the given graphs contains those points.

$\theta$	0	$\frac{\pi}{4}$	$\frac{\pi}{2}$	$\frac{3\pi}{4}$	$\pi$	$\frac{5\pi}{4}$	$\frac{3\pi}{2}$	$\frac{7\pi}{4}$	$2\pi$
$r$	1	$1 + \sqrt{2}$	-1	$1 + \sqrt{2}$	1	$1 - \sqrt{2}$	3	$1 - \sqrt{2}$	1

So the matching graph should be F.

49.  $r = 3\cos(\theta) \rightarrow r^2 = 3r\cos(\theta) \rightarrow x^2 + y^2 = 3x$  in Cartesian coordinates. Using the method of completing square:

$$x^2 - 3x + y^2 = 0$$



$$\left(x - \frac{3}{2}\right)^2 - \frac{9}{4} + y^2 = 0, \text{ or } \left(x - \frac{3}{2}\right)^2 + y^2 = \frac{9}{4}.$$

This is an equation of circle centered at  $\left(\frac{3}{2}, 0\right)$  with radius  $\frac{3}{2}$ . Therefore the graph looks like:

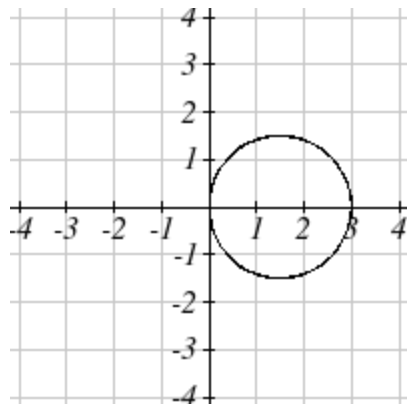

51. We'll start with a table of values, and plot them on the graph.

$\theta$	0	$\frac{\pi}{4}$	$\frac{\pi}{2}$	$\frac{3\pi}{4}$	$\pi$	$\frac{5\pi}{4}$	$\frac{3\pi}{2}$	$\frac{7\pi}{4}$	$2\pi$
$r$	0	3	0	-3	0	3	0	-3	0

So a graph of the equation is a 4-leaf rose.

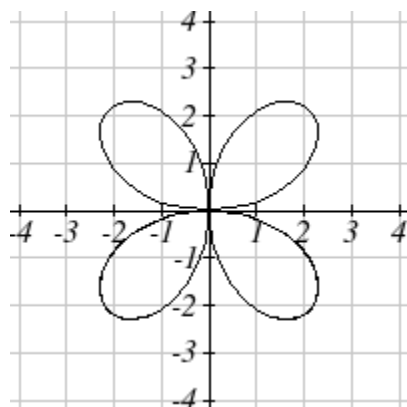

53. We'll start with a table of values, and plot them on the graph.

$\theta$	0	$\frac{\pi}{6}$	$\frac{\pi}{2}$	$\frac{5\pi}{6}$	$\pi$	$\frac{7\pi}{6}$	$\frac{3\pi}{2}$	$\frac{11\pi}{6}$	$2\pi$
$r$	0	5	-5	5	0	-5	5	-5	0

So a graph of the equation is a 3-leaf rose symmetric about the y- axis.

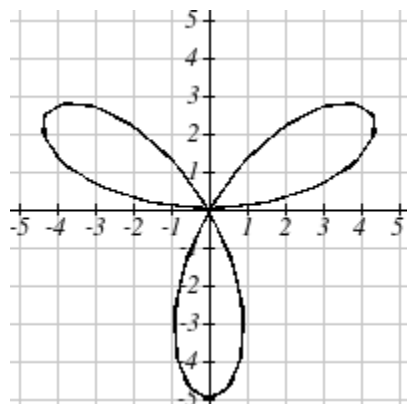

55. We'll make a table of values, and plot them on the graph.

$\theta$	0	$\frac{\pi}{4}$	$\frac{\pi}{2}$	$\frac{3\pi}{4}$	$\pi$	$\frac{5\pi}{4}$	$\frac{3\pi}{2}$	$\frac{7\pi}{4}$	$2\pi$
$r$	3	0	-3	0	3	0	-3	0	3

So a graph of the equation is a 4-leaf rose.

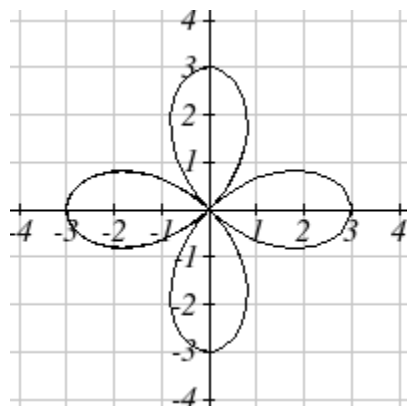

57. We'll make a table of values, and plot them on the graph.

$\theta$	0	$\frac{\pi}{2}$	$\pi$	$\frac{3\pi}{2}$	$2\pi$
$r$	4	2	0	2	4

So a graph of the equation is a cardioid symmetric about the x- axis.

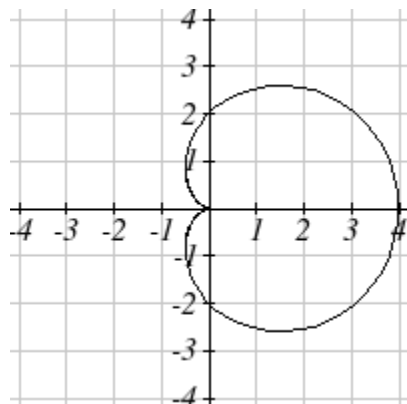

59. We'll start with a table of values.

$\theta$	0	$\frac{\pi}{4}$	$\frac{\pi}{2}$	$\frac{3\pi}{4}$	$\pi$	$\frac{5\pi}{4}$	$\frac{3\pi}{2}$	$\frac{7\pi}{4}$	$2\pi$
$r$	1	$\frac{2+3\sqrt{2}}{2}$	4	$\frac{2+3\sqrt{2}}{2}$	1	$\frac{2-3\sqrt{2}}{2}$	-2	$\frac{2-3\sqrt{2}}{2}$	1

Also, when  $r = 0$ ,  $1 + 3\sin(\theta) = 0$ , so:

$$\sin(\theta) = -\frac{1}{3}$$

$$\theta \approx -0.34 + 2k\pi$$

$$\theta \approx \pi - (-0.34) + 2k\pi = \pi + 0.34 + 2k\pi, \text{ where } k \text{ is an integer.}$$

So a graph of the equation is a limaçon symmetric about the y-axis.

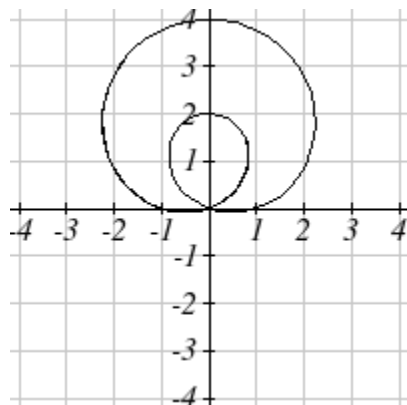

61. We'll start with a table of values.

This material was created by Shoreline Community College and edited by Rosalie Tepper. This material is licensed under a Creative Commons NonCommercial-ShareAlike license.

$\theta$	$-\pi$	$-\frac{3\pi}{4}$	$-\frac{\pi}{2}$	$-\frac{\pi}{4}$	$0$	$\frac{\pi}{4}$	$\frac{\pi}{2}$	$\frac{3\pi}{4}$	$\pi$
$r$	$-2\pi$	$-\frac{3\pi}{2}$	$-\pi$	$-\frac{\pi}{2}$	$0$	$\frac{\pi}{2}$	$\pi$	$\frac{3\pi}{2}$	$2\pi$

Observe that as  $\theta$  increases its absolute value, so does  $r$ . Therefore a graph of the equation should contain two spiral curves that are symmetric about the  $y$ -axis.

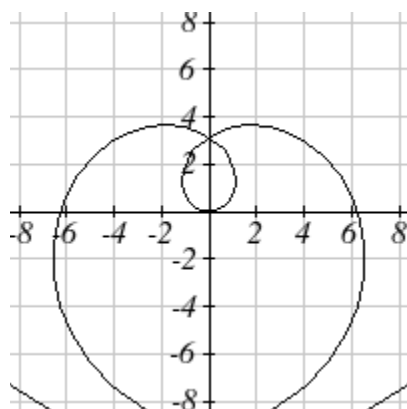

63. We'll start with a table of values.

$\theta$	$0$	$\frac{\pi}{4}$	$\frac{\pi}{3}$	$\frac{\pi}{2}$	$\frac{2\pi}{3}$	$\frac{3\pi}{4}$	$\pi$	$\frac{5\pi}{4}$	$\frac{4\pi}{3}$	$\frac{3\pi}{2}$	$\frac{5\pi}{3}$	$\frac{7\pi}{4}$	$2\pi$
$r$	$4$	$3 + \sqrt{2}$	$5$	undef.	$1$	$3 - \sqrt{2}$	$2$	$3 - \sqrt{2}$	$1$	undef.	$5$	$3 + \sqrt{2}$	$4$

Also, when  $r = 0$ ,  $3 + \sec(\theta) = 0$ , so:

$$\sec(\theta) = -3$$

$$\theta \approx 1.9106 + 2k\pi$$

$$\theta \approx 2\pi - 1.9106 + 2k\pi \approx 4.3726 + 2k\pi, \text{ where } k \text{ is an integer.}$$

So a graph of the equation is a conchoid symmetric about the  $x$ -axis.

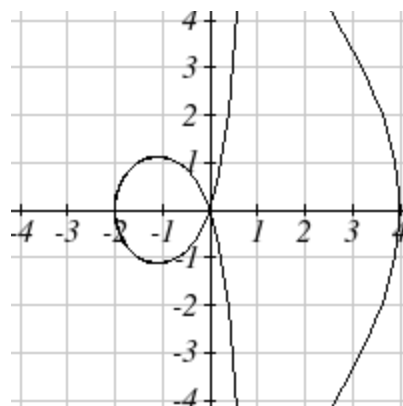

65. We'll start by choosing values of  $\theta$  to plug in, together the following table of values:

$\theta$	0	$\frac{\pi}{4}$	$\frac{\pi}{3}$	$\frac{\pi}{2}$	$\frac{2\pi}{3}$	$\frac{3\pi}{4}$	$\pi$	$\frac{5\pi}{4}$	$\frac{4\pi}{3}$	$\frac{3\pi}{2}$	$\frac{5\pi}{3}$	$\frac{7\pi}{4}$	$2\pi$
$r$	0	$\sqrt{2}$	3	undef.	-3	$-\sqrt{2}$	0	$-\sqrt{2}$	-3	undef.	3	$\sqrt{2}$	0

So a graph of the equation is a cissoid symmetric about the  $x$ -axis.

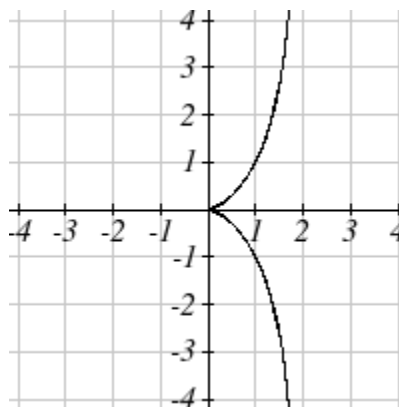

### 8.3 Solutions to Exercises

$$1. \sqrt{-9} = \sqrt{9}\sqrt{-1} = 3i$$

$$3. \sqrt{-6}\sqrt{-24} = \sqrt{6}\sqrt{-1}\sqrt{24}\sqrt{-1} = \sqrt{6}(2\sqrt{6})i^2 = 2 \cdot 6 \cdot i^2 = 12(-1) = -12$$

$$5. \frac{2+\sqrt{-12}}{2} = \frac{2+2\sqrt{3}\sqrt{-1}}{2} = 1 + i\sqrt{3}$$

$$7. (3 + 2i) + (5 - 3i) = 3 + 5 + 2i - 3i = 8 - i$$

$$9. (-5 + 3i) - (6 - i) = -5 - 6 + 3i + i = -11 + 4i$$

$$11. (2 + 3i)(4i) = 8i + 12i^2 = 8i + 12(-1) = 8i - 12$$

$$13. (6 - 2i)(5) = 30 - 10i$$

$$15. (2 + 3i)(4 - i) = 8 - 2i + 12i - 3i^2 = 8 + 10i - 3(-1) = 11 + 10i$$

$$17. (4 - 2i)(4 + 2i) = 4^2 - (2i)^2 = 16 - 4i^2 = 16 - 4(-1) = 20$$

$$19. \frac{3+4i}{2} = \frac{3}{2} + \frac{4i}{2} = \frac{3}{2} + 2i$$

$$21. \frac{-5+3i}{2i} = \frac{-5}{2i} + \frac{3i}{2i} = \frac{-5i}{2i^2} + \frac{3}{2} = \frac{-5i}{-2} + \frac{3}{2} = \frac{5i}{2} + \frac{3}{2}$$

$$23. \frac{2-3i}{4+3i} = \frac{(2-3i)(4-3i)}{(4+3i)(4-3i)} = \frac{8-6i-12i+9i^2}{4^2-(3i)^2} = \frac{8-18i-9}{16-9(-1)} = \frac{-18i-1}{25}$$

$$25. i^6 = (i^2)^3 = (-1)^3 = -1$$

$$27. i^{17} = (i^{16})i = (i^2)^8 i = (-1)^8 i = i$$

$$29. 3e^{2i} = 3\cos(2) + i3\sin(2) \approx -1.248 + 2.728i$$

$$31. 6e^{\frac{\pi}{6}i} = 6\cos\left(\frac{\pi}{6}\right) + i6\sin\left(\frac{\pi}{6}\right) = 6\left(\frac{\sqrt{3}}{2}\right) + i6\left(\frac{1}{2}\right) = 3\sqrt{3} + 3i$$

$$33. 3e^{\frac{5\pi}{4}i} = 3\cos\left(\frac{5\pi}{4}\right) + i3\sin\left(\frac{5\pi}{4}\right) = 3\left(-\frac{\sqrt{2}}{2}\right) + i3\left(-\frac{\sqrt{2}}{2}\right) = -\frac{3\sqrt{2}}{2} - \frac{3\sqrt{2}}{2}i$$

35.  $6 = x + iy$  so  $x = 6$  and  $y = 0$ . Also,  $r^2 = x^2 + y^2 = 6^2 + 0^2 = 6^2$  so  $r = 6$  (since  $r \geq 0$ ). Also, using  $x = r\cos(\theta)$ :  $6 = 6\cos(\theta)$ , so  $\theta = 0$ . So the polar form is  $6e^{0i}$ .

37.  $-4i = x + iy$  so  $x = 0$  and  $y = -4$ . Also,  $r^2 = x^2 + y^2 = 0^2 + (-4)^2 = 16$  so  $r = 4$  (since  $r \geq 0$ ). Using  $y = r\sin(\theta)$ :  $-4 = 4\sin(\theta)$ , so  $\sin(\theta) = -1$ , so  $\theta = \frac{3\pi}{2}$ . So the polar form is  $4e^{\frac{3\pi}{2}i}$ .

39.  $2 + 2i = x + iy$  so  $x = 2$  and  $y = 2$ . Then  $r^2 = x^2 + y^2 = 2^2 + 2^2 = 8$ , so  $r = 2\sqrt{2}$  (since  $r \geq 0$ ). Also  $x = r\cos(\theta)$  and  $y = r\sin(\theta)$ , so:

$$2 = 2\sqrt{2}\cos(\theta) \text{ so } \cos(\theta) = \frac{1}{\sqrt{2}} = \frac{\sqrt{2}}{2}, \text{ and } 2 = 2\sqrt{2}\sin(\theta) \text{ so } \sin(\theta) = \frac{1}{\sqrt{2}} = \frac{\sqrt{2}}{2}$$

Therefore  $(x, y)$  is located in the quadrant I, or  $\theta = \frac{\pi}{4}$ . So the polar form is  $2\sqrt{2}e^{\frac{\pi}{4}i}$ .

41.  $-3 + 3i = x + yi$  so  $x = -3$  and  $y = 3$ . Then  $r^2 = x^2 + y^2 = (-3)^2 + 3^2 = 18$ , so  $r = 3\sqrt{2}$  (since  $r \geq 0$ ).

Also  $x = r\cos(\theta)$  and  $y = r\sin(\theta)$ , so:

$$-3 = 3\sqrt{2}\cos(\theta) \text{ so } \cos(\theta) = \frac{-1}{\sqrt{2}} = -\frac{\sqrt{2}}{2} \quad \text{and} \quad 3 = 3\sqrt{2}\sin(\theta) \text{ so } \sin(\theta) = \frac{1}{\sqrt{2}} = \frac{\sqrt{2}}{2}$$

Therefore  $(x, y)$  is located in the quadrant II, or  $\theta = \frac{3\pi}{4}$ . So the polar form is  $3\sqrt{2}e^{\frac{3\pi i}{4}}$ .

43.  $5 + 3i = x + yi$  so  $x = 5$  and  $y = 3$ . Then  $r^2 = x^2 + y^2 = 5^2 + 3^2 = 34$ , so  $r = \sqrt{34}$  (since  $r \geq 0$ ). Also

$x = r\cos(\theta)$  and  $y = r\sin(\theta)$ , so:

$$5 = \sqrt{34}\cos(\theta) \text{ so } \cos(\theta) = \frac{5}{\sqrt{34}} \quad \text{and} \quad 3 = \sqrt{34}\sin(\theta) \text{ so } \sin(\theta) = \frac{3}{\sqrt{34}}$$

Therefore  $(x, y)$  is located in the quadrant I, or  $\theta \approx 0.54042$ . So the polar form is  $\sqrt{34}e^{0.54042i}$ .

45.  $-3 + i = x + yi$  so  $x = -3$  and  $y = 1$ . Then  $r^2 = x^2 + y^2 = (-3)^2 + 1^2 = 10$ , so  $r = \sqrt{10}$  (since  $r \geq 0$ ).

Also  $x = r\cos(\theta)$  and  $y = r\sin(\theta)$ , so:

$$-3 = \sqrt{10}\cos(\theta) \text{ so } \cos(\theta) = \frac{-3}{\sqrt{10}} \quad \text{and} \quad 1 = \sqrt{10}\sin(\theta) \text{ so } \sin(\theta) = \frac{1}{\sqrt{10}}$$

Therefore  $(x, y)$  is located in the quadrant II, or  $\theta \approx \pi - 0.32175 \approx 2.82$ . So the polar form is  $\sqrt{10}e^{2.82i}$ .

47.  $-1 - 4i = x + yi$  so  $x = -1$  and  $y = -4$ . Then  $r^2 = x^2 + y^2 = (-1)^2 + (-4)^2 = 17$ , so  $r = \sqrt{17}$  (since  $r \geq 0$ ).

Also  $x = r\cos(\theta)$  and  $y = r\sin(\theta)$ , so:

$$-1 = \sqrt{17}\cos(\theta) \text{ so } \cos(\theta) = \frac{-1}{\sqrt{17}} \quad \text{and} \quad -4 = \sqrt{17}\sin(\theta) \text{ so } \sin(\theta) = \frac{-4}{\sqrt{17}}$$

Therefore  $(x, y)$  is located in the quadrant III, or  $\theta \approx \pi + 1.81577 \approx 4.9574$ . So the polar form is  $\sqrt{17}e^{4.9574i}$ .

49.  $5 - i = x + yi$  so  $x = 5$  and  $y = -1$ . Then  $r^2 = x^2 + y^2 = 5^2 + (-1)^2 = 26$ , so  $r = \sqrt{26}$  (since  $r \geq 0$ ).

Also  $x = r\cos(\theta)$  and  $y = r\sin(\theta)$ , so:

$$5 = \sqrt{26}\cos(\theta) \text{ so } \cos(\theta) = \frac{5}{\sqrt{26}} \quad \text{and} \quad -1 = \sqrt{26}\sin(\theta) \text{ so } \sin(\theta) = \frac{-1}{\sqrt{26}}$$

Therefore  $(x, y)$  is located in the quadrant IV, or  $\theta \approx 2\pi - 0.1974 \approx 6.0858$ . So the polar form is  $\sqrt{26}e^{6.0858i}$ .

$$51. \left(3e^{\frac{\pi i}{6}}\right)\left(2e^{\frac{\pi i}{4}}\right) = (3)(2)\left(e^{\frac{\pi i}{6}}\right)\left(e^{\frac{\pi i}{4}}\right) = 6e^{\frac{\pi i}{6} + \frac{\pi i}{4}} = 6e^{\frac{5\pi i}{12}}$$

$$53. \frac{6e^{\frac{3\pi}{4}i}}{3e^{\frac{\pi}{6}i}} = \left(\frac{6}{3}\right) \left(\frac{e^{\frac{3\pi}{4}i}}{e^{\frac{\pi}{6}i}}\right) = 2e^{\frac{3\pi}{4}i - \frac{\pi}{6}i} = 2e^{\frac{7\pi}{12}i}.$$

$$55. (2e^{\frac{\pi}{4}i})^{10} = (2^{10}) \left(\left(e^{\frac{\pi}{4}i}\right)^{10}\right) = 1024e^{\frac{10\pi}{4}i} = 1024e^{\frac{5\pi}{2}i}$$

$$57. \sqrt{16e^{\frac{2\pi}{3}i}} = \sqrt{16}\sqrt{e^{\frac{2\pi}{3}i}} = 4e^{\frac{2\pi}{3}i \cdot \frac{1}{2}} = 4e^{\frac{\pi}{3}i}.$$

59.  $(2 + 2i)^8 = ((2 + 2i)^2)^4 = (4 + 8i + 4i^2)^4 = (4 + 8i - 4)^4 = (8i)^4 = 8^4 i^4 = 4096$ . Note that you could instead do this problem by converting  $2 + 2i$  to polar form (done it problem 39) and then proceeding:  $(2 + 2i)^8 = (2\sqrt{2}e^{\frac{\pi}{4}i})^8 = (2\sqrt{2})^8 (e^{\frac{\pi}{4}i})^8 = 4096 (e^{\frac{\pi}{4}i \cdot 8}) = 4096e^{2\pi i} = 4096$ .

61.  $\sqrt{-3 + 3i} = (-3 + 3i)^{\frac{1}{2}}$ . Let's convert  $-3 + 3i$  to polar form:  $-3 + 3i = x + yi$ . Then  $x = -3$  and  $y = 3$ . Then  $r^2 = x^2 + y^2 = (-3)^2 + 3^2 = 18$  so  $r = 3\sqrt{2}$  (since  $r \geq 0$ ). Also:

$$\begin{aligned} x &= r\cos(\theta) & \text{and} & & y &= r\sin(\theta) \\ -3 &= 3\sqrt{2}\cos(\theta) & & & 3 &= 3\sqrt{2}\sin(\theta) \\ \cos(\theta) &= \frac{-1}{\sqrt{2}} = \frac{-\sqrt{2}}{2} & & & \sin(\theta) &= \frac{1}{\sqrt{2}} = \frac{\sqrt{2}}{2} \end{aligned}$$

Therefore  $(x, y)$  is located in the quadrant II, and  $\theta = \frac{3\pi}{4}$ . So  $(-3 + 3i)^{\frac{1}{2}} = (3\sqrt{2}e^{i\frac{3\pi}{4}})^{\frac{1}{2}} = \sqrt{3\sqrt{2}}e^{i\frac{3\pi}{8}}$ . To put our answer in  $a + bi$  form:

$$\begin{aligned} a &= r\cos(\theta) = \sqrt{3\sqrt{2}}\cos\left(\frac{3\pi}{8}\right) \approx 0.78824 \\ b &= r\sin(\theta) = \sqrt{3\sqrt{2}}\sin\left(\frac{3\pi}{8}\right) \approx 1.903 \end{aligned}$$

Thus  $\sqrt{-3 + 3i} \approx 0.78824 + 1.903i$ .

63.  $\sqrt[3]{5 + 3i} = (5 + 3i)^{\frac{1}{3}}$ . Let's convert  $5 + 3i$  to polar form:  $5 + 3i = x + yi$ . Then  $x = 5$  and  $y = 3$ . Then  $r^2 = x^2 + y^2 = 5^2 + 3^2 = 34$  so  $r = \sqrt{34}$  (since  $r \geq 0$ ). Also:



$$\begin{aligned}
 x &= r \cos(\theta) & \text{and} & & y &= r \sin(\theta) \\
 5 &= \sqrt{34} \cos(\theta) & & & 3 &= \sqrt{34} \sin(\theta) \\
 \cos(\theta) &= \frac{5}{\sqrt{34}} & & & \sin(\theta) &= \frac{3}{\sqrt{34}}
 \end{aligned}$$

Therefore  $(x, y)$  is located in the quadrant I, and  $\theta \approx 0.54042$ . So  $(5 + 3i)^{\frac{1}{3}} = (\sqrt{34}e^{0.54042i})^{\frac{1}{3}} = \sqrt[3]{34}e^{0.18014i}$ . To put our answer in  $a + bi$  form:

$$a = r \cos(\theta) = \sqrt[3]{34} \cos(0.18014) \approx 1.771$$

$$b = r \sin(\theta) = \sqrt[3]{34} \sin(0.18014) \approx 0.3225$$

Thus  $\sqrt[3]{5 + 3i} \approx 1.771 + 0.3225i$ .

65. If  $z^5 = 2$  then  $z = 2^{\frac{1}{5}}$ . In the complex plane, 2 would sit on the horizontal axis at an angle of 0, giving the polar form  $2e^{i0}$ . Then  $(2e^{i0})^{\frac{1}{5}} = 2^{\frac{1}{5}}e^0 = 2^{\frac{1}{5}}\cos(0) + i2^{\frac{1}{5}}\sin(0) = 2^{\frac{1}{5}} \approx 1.149$ .

Since the angles  $2\pi, 4\pi, 6\pi, 8\pi,$  and  $10\pi$  are coterminal with the angle of 0,  $2^{\frac{1}{5}}$  can be represented by turns as  $(2e^{i2\pi})^{\frac{1}{5}}, (2e^{i4\pi})^{\frac{1}{5}}, (2e^{i6\pi})^{\frac{1}{5}}, (2e^{i8\pi})^{\frac{1}{5}},$  and  $(2e^{i10\pi})^{\frac{1}{5}}$  to get all solutions.

$$(2e^{i2\pi})^{\frac{1}{5}} = 2^{\frac{1}{5}} (e^{i2\pi})^{\frac{1}{5}} = 2^{\frac{1}{5}} e^{\frac{2\pi i}{5}} = 2^{\frac{1}{5}} \cos\left(\frac{2\pi}{5}\right) + 2^{\frac{1}{5}} i \sin\left(\frac{2\pi}{5}\right) \approx 0.355 + 1.092i$$

$$(2e^{i4\pi})^{\frac{1}{5}} = 2^{\frac{1}{5}} (e^{i4\pi})^{\frac{1}{5}} = 2^{\frac{1}{5}} e^{\frac{4\pi i}{5}} = 2^{\frac{1}{5}} \cos\left(\frac{4\pi}{5}\right) + 2^{\frac{1}{5}} i \sin\left(\frac{4\pi}{5}\right) \approx -0.929 + 0.675i$$

$$(2e^{i6\pi})^{\frac{1}{5}} = 2^{\frac{1}{5}} (e^{i6\pi})^{\frac{1}{5}} = 2^{\frac{1}{5}} e^{\frac{6\pi i}{5}} = 2^{\frac{1}{5}} \cos\left(\frac{6\pi}{5}\right) + 2^{\frac{1}{5}} i \sin\left(\frac{6\pi}{5}\right) \approx -0.929 - 0.675i$$

$$(2e^{i8\pi})^{\frac{1}{5}} = 2^{\frac{1}{5}} (e^{i8\pi})^{\frac{1}{5}} = 2^{\frac{1}{5}} e^{\frac{8\pi i}{5}} = 2^{\frac{1}{5}} \cos\left(\frac{8\pi}{5}\right) + 2^{\frac{1}{5}} i \sin\left(\frac{8\pi}{5}\right) \approx 0.355 - 1.092i$$

$$(2e^{i10\pi})^{\frac{1}{5}} = 2^{\frac{1}{5}} (e^{i10\pi})^{\frac{1}{5}} = 2^{\frac{1}{5}} e^{\frac{10\pi i}{5}} = 2^{\frac{1}{5}} e^{2\pi i} = 2^{\frac{1}{5}} \cos(2\pi) + 2^{\frac{1}{5}} i \sin(2\pi) \approx 0.355 + 1.092i$$

Observe that for the angles  $2k\pi$ , where  $k$  is an integer and  $k \geq 5$ , the values of  $(2e^{i2k\pi})^{\frac{1}{5}}$  are repeated as the same as its values when  $k = 0, 1, 2, 3,$  and  $4$ . In conclusion, all complex solutions of  $z^5 = 2$  are  $1.149, 0.355 + 1.092i, -0.929 + 0.675i, -0.929 - 0.675i,$  and  $0.355 - 1.092i$ .

67. If  $z^6 = 1$  then  $z = 1^{\frac{1}{6}}$ . In the complex plane, 1 would sit on the horizontal axis at an angle of 0, giving the polar form  $e^{i0}$ . Then  $(e^{i0})^{\frac{1}{6}} = e^0 = \cos(0) + i\sin(0) = 1$ .

Since the angles  $2\pi, 4\pi, 6\pi, 8\pi, 10\pi,$  and  $12\pi$  are coterminal with the angle of 0,  $1^{\frac{1}{6}}$  can be represented by turns as  $(e^{i2\pi})^{\frac{1}{6}}, (e^{i4\pi})^{\frac{1}{6}}, (e^{i6\pi})^{\frac{1}{6}}, (e^{i8\pi})^{\frac{1}{6}}, (e^{i10\pi})^{\frac{1}{6}},$  and  $(e^{i12\pi})^{\frac{1}{6}}$ .

$$(e^{i2\pi})^{\frac{1}{6}} = e^{\frac{\pi}{3}i} = \cos\left(\frac{\pi}{3}\right) + i\sin\left(\frac{\pi}{3}\right) = \frac{1}{2} + \frac{\sqrt{3}}{2}i$$

$$(e^{i4\pi})^{\frac{1}{6}} = e^{\frac{2\pi}{3}i} = \cos\left(\frac{2\pi}{3}\right) + i\sin\left(\frac{2\pi}{3}\right) = \frac{-1}{2} + \frac{\sqrt{3}}{2}i$$

$$(e^{i6\pi})^{\frac{1}{6}} = e^{\pi i} = \cos(\pi) + i\sin(\pi) = -1$$

$$(e^{i8\pi})^{\frac{1}{6}} = e^{\frac{4\pi}{3}i} = \cos\left(\frac{4\pi}{3}\right) + i\sin\left(\frac{4\pi}{3}\right) = \frac{-1}{2} - \frac{\sqrt{3}}{2}i$$

$$(e^{i10\pi})^{\frac{1}{6}} = e^{\frac{5\pi}{3}i} = \cos\left(\frac{5\pi}{3}\right) + i\sin\left(\frac{5\pi}{3}\right) = \frac{1}{2} - \frac{\sqrt{3}}{2}i$$

$$(e^{i12\pi})^{\frac{1}{6}} = e^{2\pi i} = \cos(2\pi) + i\sin(2\pi) = 1$$

Observe that for the angles  $2k\pi$ , where  $k$  is an integer and  $k \geq 6$ , the values of  $(2e^{i2k\pi})^{\frac{1}{6}}$  are repeated as the same as its values when  $k = 0, 1, 2, 3, 4,$  and  $5$ . In conclusion, all complex solutions of  $z^6 = 1$  are  $1, \frac{1}{2} + \frac{\sqrt{3}}{2}i, \frac{-1}{2} + \frac{\sqrt{3}}{2}i, -1, \frac{-1}{2} - \frac{\sqrt{3}}{2}i,$  and  $\frac{1}{2} - \frac{\sqrt{3}}{2}i$ .

## 8.4 Solutions to Exercises

1. Initial point  $(4,0)$ ; terminal point  $(0,2)$ . The vector component form is  $\langle x_1 - x_2, y_1 - y_2 \rangle$ .  
 $\langle 0 - 4, 2 - 0 \rangle = \langle -4, 2 \rangle$

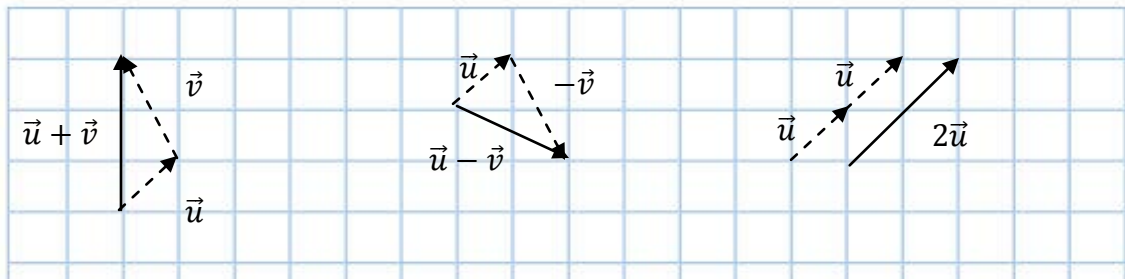

3.

5.  $\vec{u} = \langle 1, 1 \rangle$  and  $\vec{v} = \langle -1, 2 \rangle$ . The vector we need is  $\langle -4, 5 \rangle$ . To get these components as a combination of  $\vec{u}$  and  $\vec{v}$ , we need to find  $a$  and  $b$  such that  $a \cdot 1 + b \cdot (-1) = -4$  and  $a \cdot 1 + b \cdot 2 = 5$ . Solving this system gives  $a = -1$  and  $b = 3$ , so the vector is  $3\vec{v} - \vec{u}$ .

7. The component form is  $\langle 6 \cos 45^\circ, 6 \sin 45^\circ \rangle = \langle 3\sqrt{2}, 3\sqrt{2} \rangle$ .

9. The component form is  $\langle 8 \cos 220^\circ, 8 \sin 220^\circ \rangle \approx \langle -6.128, -5.142 \rangle$ .

11. Magnitude:  $|\mathbf{v}| = \sqrt{0^2 + 4^2} = 4$ ; direction:  $\tan \theta = \frac{4}{0}$  so  $\theta = 90^\circ$

13. Magnitude:  $|\mathbf{v}| = \sqrt{6^2 + 5^2} = \sqrt{61} = 7.81$ , direction:  $\tan \theta = \frac{5}{6}$ ,  $\theta = \tan^{-1} \frac{5}{6} \approx 39.806^\circ$  (first quadrant).

15. Magnitude:  $|\mathbf{v}| = \sqrt{(-2)^2 + 1^2} = \sqrt{5} \approx 2.236$ ; direction:  $\tan \theta = \frac{1}{-2} = -0.5$  which is  $180^\circ - 26.565^\circ = 153.435^\circ$  (second quadrant).

17. Magnitude:  $|\mathbf{v}| = \sqrt{2^2 + (-5)^2} = \sqrt{29} \approx 5.385$ , direction:  $\tan \theta = \frac{-5}{2}$ ,  $\theta = \tan^{-1} \frac{-5}{2} \approx -68.199^\circ$  which is  $360^\circ - 68.199^\circ = 291.801^\circ$  (fourth quadrant).

19. Magnitude:  $|\mathbf{v}| = \sqrt{(-4)^2 + (-6)^2} = \sqrt{52} \approx 7.211$ , direction:  $\tan \theta = \frac{-6}{-4}$ ,  $\theta = \tan^{-1} \frac{-6}{-4} \approx 56.3^\circ$  which is  $180^\circ + 56.3^\circ = 236.3^\circ$  (third quadrant).

21.  $\vec{u} + \vec{v} = \langle 2 + 1, -3 + 5 \rangle = \langle 3, 2 \rangle$ ;  $\vec{u} - \vec{v} = \langle 2 - 1, -3 - 5 \rangle = \langle 1, -8 \rangle$ ;  $2\vec{u} = 2 \langle 2, -3 \rangle$  and  $3\vec{v} = 3 \langle 1, 5 \rangle$  so  $2\vec{u} - 3\vec{v} = \langle 4 - 3, -6 - 15 \rangle = \langle 1, -21 \rangle$ .

23.

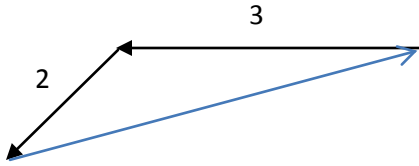

The first part of her walk can be defined as a vector form of  $\langle -3, 0 \rangle$ . The second part of her walk can be defined as  $\langle 2 \cos(225^\circ), 2 \sin(225^\circ) \rangle$ . Then the total is  $\langle -3 +$

$2 \cos 225^\circ, 0 + 2 \sin 225^\circ \rangle = \langle -3 - \sqrt{2}, -\sqrt{2} \rangle$ . The magnitude

is  $\sqrt{(-3 - \sqrt{2})^2 + (-\sqrt{2})^2} = \sqrt{21.485} \approx 4.635$  miles. Direction:  $\tan \theta = \frac{\sqrt{2}}{3 + \sqrt{2}} = 0.3203$ ,  $\theta \approx$

17.76 north of east.

25.

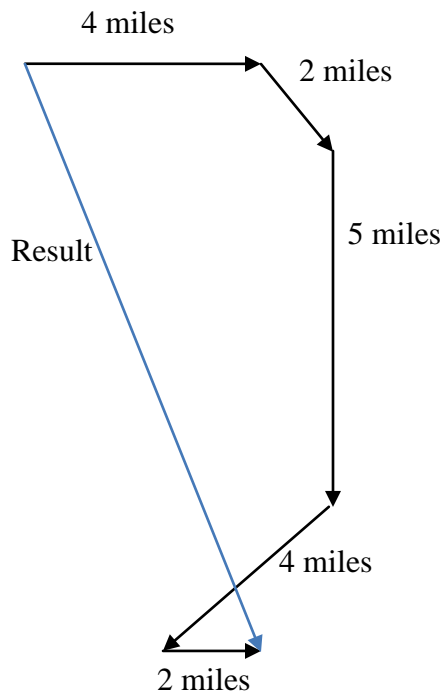

How far they have walked:  $4 + 2 + 5 + 4 + 2 = 17$  miles. How far they had to walk home, if they had walked straight home: the 5 parts of their walk can be considered into 5 vector forms:

This material was created by Shoreline Community College and edited by Rosalie Tepper. This material is licensed under a Creative Commons NonCommercial-ShareAlike license.

1.  $\langle 4, 0 \rangle$ , 2.  $\langle 2\cos 45^\circ, 2\sin 45^\circ \rangle$ , 3.  $\langle 0, 5 \rangle$ , 4.  $\langle -4\cos 45^\circ, 4\sin 45^\circ \rangle$ , 5.  $\langle 2, 0 \rangle$

Total horizontal components of the vectors:  $\langle 4 + 2\cos 45^\circ + 0 - 4\cos 45^\circ + 2 \rangle = \langle 4 + \sqrt{2} + 0 - 2\sqrt{2} + 2 \rangle = \langle 6 - \sqrt{2} \rangle$

Total vertical components of the vectors:  $\langle 0 + 2\sin 45^\circ + 5 + 4\sin 45^\circ + 0 \rangle = \langle \sqrt{2} + 5 + 2\sqrt{2} \rangle = \langle 5 + 3\sqrt{2} \rangle$

The total distance is the magnitude of this vector:

$$\sqrt{(6 - \sqrt{2})^2 + (5 + 3\sqrt{2})^2} = \sqrt{21.029 + 85.426} \approx 10.318 \text{ miles.}$$

$$27. \vec{F}_1 + \vec{F}_2 + \vec{F}_3 = \langle -8 + 0 + 4, -5 + 1 - 7 \rangle = \langle -4, -11 \rangle$$

29.

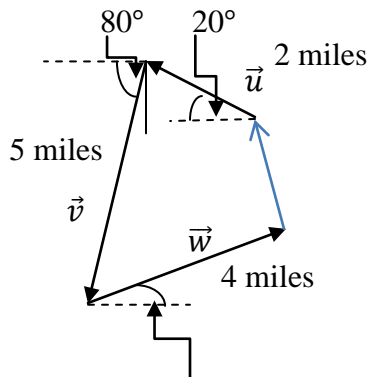

15°

$$\vec{u} = \langle 3\cos 160^\circ, 3\sin 160^\circ \rangle$$

$$\vec{v} = \langle 5\cos 260^\circ, 5\sin 260^\circ \rangle$$

$$\vec{w} = \langle 4\cos 15^\circ, 4\sin 15^\circ \rangle$$

$$\begin{aligned} \vec{u} + \vec{v} + \vec{w} &= \langle 3\cos 160^\circ + 5\cos 260^\circ + 4\cos 15^\circ, 3\sin 160^\circ + 5\sin 260^\circ + 4\sin 15^\circ \rangle \\ &= \langle 0.1764, -2.8627 \rangle \end{aligned}$$

Note that this vector represents the person's displacement from home, so the path to return home is the opposite of this vector, or  $\langle -0.1764, 2.8627 \rangle$ . To find its magnitude:

$$|\vec{u} + \vec{v} + \vec{w}| = \langle -0.1764, 2.8627 \rangle = \sqrt{0.03111 + 8.1950} = 2.868 \text{ miles.}$$

Directions:  $\tan \theta = \frac{2.8627}{-0.1764}$ , so  $\theta = 93.526^\circ$ , which is  $86.474^\circ$  North of West or  $90 - 86.474 = 3.526^\circ$  West of North.

31.

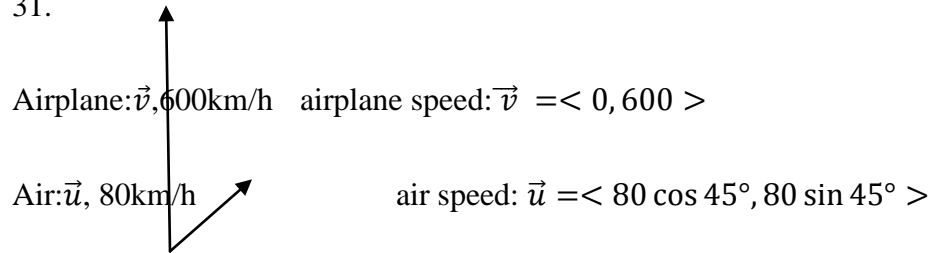

Effective airplane speed in relation to the ground  $\vec{w} = \vec{u} + \vec{v} = \langle 0 + 80 \cos 45^\circ, 600 + 80 \sin 45^\circ \rangle = \langle 40\sqrt{2}, 600 + 40\sqrt{2} \rangle$ . Then  $|\vec{w}| = \sqrt{(40\sqrt{2})^2 + (600 + 40\sqrt{2})^2} = 659 \text{ km/h}$ . To find the direction to the horizontal axis:  $\tan \theta = \frac{600 + 40\sqrt{2}}{40\sqrt{2}} = 11.607$ . Then  $\theta = 85.076^\circ$ . So the plane will fly  $(90 - 85.076)^\circ = 4.924^\circ$  off the course.

33. Suppose the plane flies at an angle  $\theta^\circ$  to north of west axis. Then its vector components are  $\langle 550 \cos \theta, 550 \sin \theta \rangle$ . The vector components for wind are  $\langle 60 \cos 45^\circ, 60 \sin 45^\circ \rangle$ .

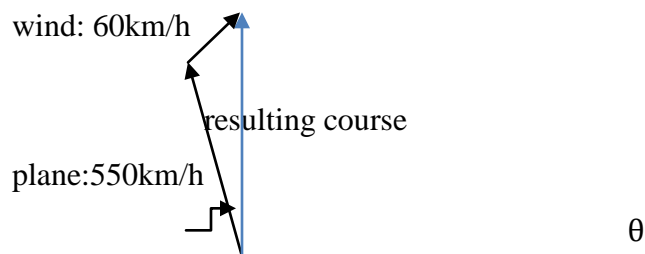

Since the plane needs to head due north, the horizontal components of the vectors add to zero:

$$550 \cos(90^\circ + \theta) + 60 \cos 45^\circ = 0$$

$$550 \cos(90^\circ + \theta) = -60 \cos 45 = 30\sqrt{2}$$

$$\cos(90^\circ + \theta) = \frac{30\sqrt{2}}{550}$$

$90^\circ + \theta = 85.576^\circ$  or  $94.424^\circ$ . Since  $90^\circ + \theta$  should give an obtuse angle, we use the latter solution, and we conclude that the plane should fly  $4.424^\circ$  degrees west of north.

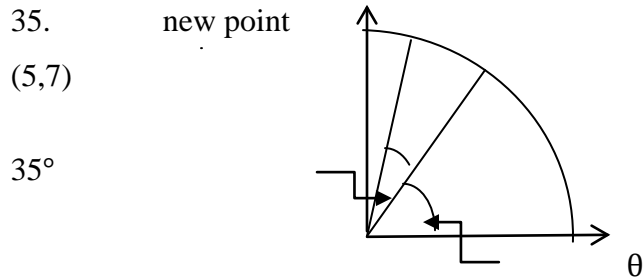

Suppose the angle the point  $(5,7)$  makes with the horizontal axis is  $\theta$ , then  $\tan\theta = \frac{7}{5}$ ,  $\theta = \tan^{-1}\frac{7}{5} = 54.46^\circ$ . The radius of the quarter circle  $= \sqrt{5^2 + 7^2} = \sqrt{74} = 8.602$ . The angle which formed by the rotation from the point  $(5, 7)$  is  $= 35^\circ$ , so the new angle formed by the rotation from the horizontal axis  $= 54.46^\circ + 35^\circ = 89.46^\circ$ . So the new coordinate points are:  $(8.602 \cos 89.46^\circ, 8.602 \sin 89.46^\circ) = (0.081, 8.602)$ .

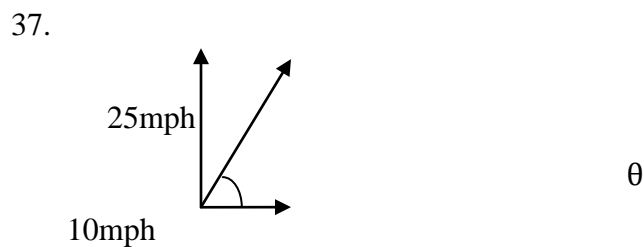

$\tan\theta = \frac{25}{10}$ , therefore  $\theta = 68.128^\circ$ ; in relation to car's forward direction it is  $= 90 - 68.128 = 21.80^\circ$ .

## 8.5 Solutions to Exercises

1. The first equation  $x = t$  can be substituted into the second equation to get  $y(x) = x^2 - 1$ , corresponding to graph C. [Note: earlier versions of the textbook contained an error in which the graph was not shown.]

3. Given  $x(t) = 4 \sin(t)$ ,  $y(t) = 2 \cos(t)$ :  $\frac{x}{4} = \sin(t)$ ,  $\frac{y}{2} = \cos(t)$ . We know  $\sin^2(t) + \cos^2(t) = 1$ , so  $\frac{x^2}{4^2} + \frac{y^2}{2^2} = 1$ . This is the form of an ellipse containing the points  $(\pm 4, 0)$  and  $(0, \pm 2)$ , so the graph is E.

5. From the first equation,  $t = x - 2$ . Substituting into the second equation,  $y = 3 - 2(x - 2) = 3 - 2x + 4 = -2x + 7$ , a linear equation through  $(0, 7)$  with slope -2, so it corresponds to graph F.

7. It appears that  $x(t)$  and  $y(t)$  are both sinusoidal functions:  $x(t) = \sin(t) + 2$  and  $y(t) = -\sin(t) + 5$ . Using the substitution  $\sin(t) = x - 2$  from the first equation into the second equation, we get  $y = -(x - 2) + 5 = -x + 7$ , a line with slope -1 and y-intercept 7. Note that since  $-1 \leq \sin(t) \leq 1$ ,  $x$  can only range from 1 to 3, and  $y$  ranges from 4 to 6, giving us just a portion of the line.

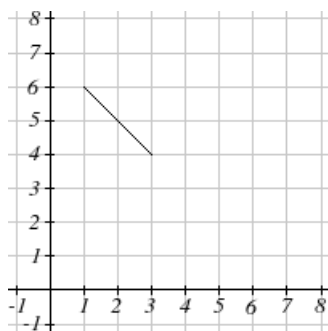

9. We can identify  $(x, y)$  pairs on the graph, as follows:

x	y
0	0



1	-1,1
2	$\approx -3,3$
3	$\approx -5,5$

It appears that this relationship could be described by the equation  $y = \pm\sqrt{x^3}$ , so we can use the parametric equations  $x(t) = t^2$  and  $y(t) = t^3$ .

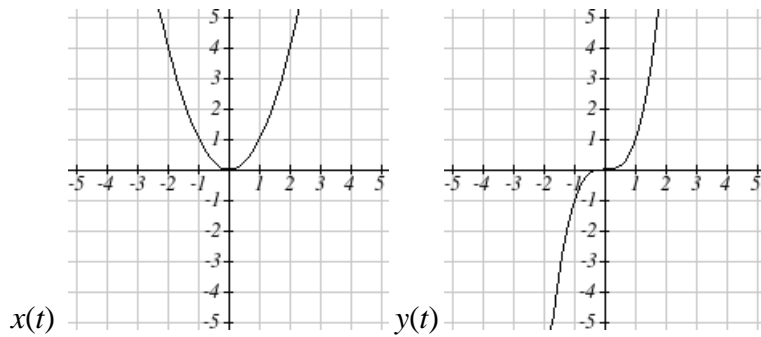

11. From the first equation, we get  $t = \frac{1}{2}(x - 1)$ , and since  $t$  ranges from -2 to 2,  $x$  must range from -3 to 5. Substituting into the second equation, we get  $y = \left(\frac{1}{2}(x - 1)\right)^2 = \frac{1}{4}(x - 1)^2$ .

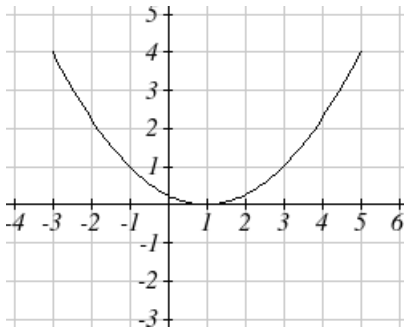

13. From the first equation,  $t = 5 - x$ . Substituting into the second equation,  $y = 8 - 2(5 - x) = 8 - 10 + 2x$ , so the Cartesian equation is  $y = 2x - 2$ .

15. From the first equation,  $t = \frac{x-1}{2}$ . Substituting into the second equation,  $y = 3\sqrt{\left(\frac{x-1}{2}\right)}$ .

17. From the first equation,  $t = \ln\left(\frac{x}{2}\right)$ . Substituting into the second equation,  $y = 1 - 5\ln\left(\frac{x}{2}\right)$ .

19. From the second equation,  $t = \frac{y}{2}$ . Substituting into the first equation,  $x = \left(\frac{y}{2}\right)^3 - \frac{y}{2}$ .
21. Note that the second equation can be written as  $y = (e^{2t})^3$ . Then substituting  $x = e^{2t}$  from the first equation into this new equation, we get  $y = x^3$ .
23. From the first equation,  $\cos(t) = \frac{x}{4}$ . From the second equation,  $\sin(t) = \frac{y}{5}$ . Since  $\sin^2(t) + \cos^2(t) = 1$ , we get  $\frac{x^2}{4^2} + \frac{y^2}{5^2} = 1$ .
25. The simplest solution is to let  $x(t) = t$ . Then substituting  $t$  for  $x$  into the given equation, we get  $y(t) = 3t^2 + 3$ .
27. Since the given equation is solved for  $x$ , the simplest solution is to let  $y(t) = t$ . Then substituting  $t$  for  $y$  into the given equation, we get  $x(t) = 3 \log(t) + t$ .
29. Note that this is an equation for an ellipse passing through points  $(\pm 2, 0)$  and  $(0, \pm 3)$ . We can think of this as the unit circle  $(\cos(t), \sin(t))$  stretched 2 units horizontally and 3 units vertically, so  $x(t) = 2 \cos(t)$  and  $y(t) = 3 \sin(t)$ .
31. There are several possible answers, two of which are included here. It appears that the given graph is the graph of  $y = \sqrt[3]{x} + 2$ , so one possible solution is  $x(t) = t$  and  $y(t) = \sqrt[3]{t} + 2$ . We could also look at the equation as  $x = (y - 2)^3$ . To parameterize this, we can let  $x(t) = t^3$ . We'd then need  $t = y - 2$ , so  $y(t) = t + 2$ .
- 33.
33. The given graph appears to be the graph of  $y = -(x + 1)^2$ . One possible solution is to let  $y(t) = -t^2$ . We'd then need  $t = x + 1$ , so  $x(t) = t - 1$ .
35. Since the Cartesian graph is a line, we can allow both  $x(t)$  and  $y(t)$  to be linear, i.e.  $x(t) = m_1 t + b_1$  and  $y(t) = m_2 t + b_2$ . When considering  $x$  in terms of  $t$ , the slope of the line

will be  $m_1 = \frac{2-(-1)}{1} = 3$ . Note that  $b_1$  is the value of  $x$  when  $t = 0$ , so  $b_1 = -1$ . Then  $x(t) = 3t - 1$ . Likewise,  $y(t)$  will have a slope of  $m_2 = \frac{5-3}{0-1} = -2$ , and  $b_2 = y(0) = 5$ . Then  $y(t) = -2t + 5$ .

37. Since the range of the cosine function is  $[-1, 1]$  and the range of  $x$  shown is  $[-4, 4]$ , we can conclude  $a = 4$ . By an analogous argument,  $c = 6$ . then  $x(t) = 4\cos(bt)$  and  $y(t) = 6\sin(dt)$

Since  $x(0) = 4\cos(b \cdot 0) = 4$  for any value of  $b$ , and  $y(0) = 6\sin(d \cdot 0) = 0$  for any value of  $d$ , the point  $(4, 0)$  is where  $t = 0$ . If we trace along the graph until we return to this point, the  $x$ -coordinate moves from its maximum value of 4 to its minimum of value -4 and back exactly 3 times, while the  $y$ -coordinate only reaches its maximum and minimum value, 6 and -6 respectively, exactly once. This means that the period of  $y(t)$  must be 3 times as large as the period of  $x(t)$ . It doesn't matter what the periods actually are, as long as this ratio is preserved. Recall that  $b$  and  $d$  have an inverse relation to the period ( $b = \frac{2\pi}{\text{period of } x}$ , and similarly for  $d$  and  $y$ ), so  $d$  must be one third of  $b$  for  $y$  to have three times the period of  $x$ . So let's let  $b = 3$  and  $d = 1$ . Then  $x(t) = 4\cos(3t)$  and  $y(t) = 6\sin(t)$ .

39. Since the range of the cosine function is  $[-1, 1]$  and the range of  $x$  shown is  $[-4, 4]$ , we can conclude  $a = 4$ . By an analogous argument,  $c = 3$ . then  $x(t) = 4\cos(bt)$  and  $y(t) = 3\sin(dt)$ .

Since  $x(0) = 4\cos(b \cdot 0) = 4$  for any value of  $b$ , and  $y(0) = 3\sin(d \cdot 0) = 0$  for any value of  $d$ , the point  $(4, 0)$  is where  $t = 0$ . From this point, imagine tracing the figure until the whole figure is drawn and we return to this starting point. (Note that in order to do that, when reaching  $(-4, 3)$  or  $(-4, -3)$ , we must backtrack along the same path.) The  $x$ -coordinate moves from its maximum value of 4 to its minimum of value -4 and back twice, while the  $y$ -coordinate moves through its maximum and minimum values, 3 and -3 respectively, three times. If we think about compressing the graphs of the standard sine and cosine graphs to increase the period accordingly (as in Chapter 6), we need  $b = 2$  (to change the cosine period from  $2\pi$  to  $\pi$ ) and  $d = 3$  (to change the sine period from  $2\pi$  to  $\frac{2\pi}{3}$ ). Then  $x(t) = 4\cos(2t)$  and  $y(t) = 3\sin(3t)$ .

41. Since distance = rate · time, we can model the horizontal distance at  $x(t) = 15t$ . Then  $t = \frac{x}{15}$ . Substituting this into the  $y(t)$  equation, we get  $y(x) = -16\left(\frac{x}{15}\right)^2 + 20\left(\frac{x}{15}\right)$ .

43. We'll model the motion around the larger circle,  $x_L(t)$  and  $y_L(t)$ , and around the smaller circle relative to the position on the larger circle,  $x_S(t)$  and  $y_S(t)$ , and add the  $x$  and  $y$  components from each to get our final answer.

Since the larger circle has diameter 40, its radius is 20. The motion starts in the center with regard to its horizontal position, at its lowest vertical point, so if we model  $x_L$  with a sine function and  $y_L$  with a cosine function, we will not have to find a phase shift for either. If we impose a coordinate system with the origin on the ground directly below the center of the circle, we get  $x_L(t) = 20\sin(Bt)$  and  $y_L(t) = -20\cos(Bt) + 35$ . The period of the large arm is 5 seconds, so  $B = \frac{2\pi}{\text{period}} = \frac{2\pi}{5}$ . Then  $x_L(t) = 20\sin\left(\frac{2\pi}{5}t\right)$  and  $y_L(t) = -20\cos\left(\frac{2\pi}{5}t\right) + 35$ .

The small arm has radius 8 and period 2, and also starts at its lowest point, so by similar arguments,  $x_S(t) = 8\sin(\pi t)$  and  $y_S(t) = -8\cos(\pi t)$ .

Adding the coordinates together, we get  $x(t) = 20\sin\left(\frac{2\pi}{5}t\right) + 8\sin(\pi t)$  and  $y(t) = -20\cos\left(\frac{2\pi}{5}t\right) - 8\cos(\pi t) + 35$ .