

Historical Counting Systems

Introduction and Basic Number and Counting Systems

Introduction

As we begin our journey through the history of mathematics, one question to be asked is “Where do we start?” Depending on how you view mathematics or numbers, you could choose any of a number of launching points from which to begin. Howard Eves suggests the following list of possibilities.¹

Where to start the study of the history of mathematics...

- At the first logical geometric “proofs” traditionally credited to Thales of Miletus (600 BCE).
- With the formulation of methods of measurement made by the Egyptians and Mesopotamians/Babylonians.
- Where prehistoric peoples made efforts to organize the concepts of size, shape, and number.
- In pre-human times in the very simple number sense and pattern recognition that can be displayed by certain animals, birds, etc.
- Even before that in the amazing relationships of number and shapes found in plants.
- With the spiral nebulae, the natural course of planets, and other universe phenomena.

We can choose no starting point at all and instead agree that mathematics has *always* existed and has simply been waiting in the wings for humans to discover. Each of these positions can be defended to some degree and which one you adopt (if any) largely depends on your philosophical ideas about mathematics and numbers.

Nevertheless, we need a starting point. And without passing judgment on the validity of any of these particular possibilities, we will choose as our starting point the emergence of the idea of number and the process of counting as our launching pad. This is done primarily as a practical matter given the nature of this course. In the following chapter, we will try to focus on two main ideas. The first will be an examination of basic number and counting systems and the symbols that we use for numbers. We will look at our own modern (Western) number system as well those of a couple of selected civilizations to see the differences and diversity that is possible when humans start counting. The second idea we will look at will be base systems. By comparing our own base-ten (decimal) system with other bases, we will quickly become aware that the system that we are so used to, when slightly changed, will challenge our notions about numbers and what symbols for those numbers actually mean.

Recognition of More vs. Less

The idea of number and the process of counting goes back far beyond history began to be recorded. There is some archeological evidence that suggests that humans were counting as far back as 50,000 years ago.² However, we do not really know how this process started or developed over time. The best we can do is to make a good guess as to how things progressed. It is probably not hard to believe that even the earliest humans had some sense

of *more* and *less*. Even some small animals have been shown to have such a sense. For example, one naturalist tells of how he would secretly remove one egg each day from a plover's nest. The mother was diligent in laying an extra egg every day to make up for the missing egg. Some research has shown that hens can be trained to distinguish between even and odd numbers of pieces of food.³ With these sorts of findings in mind, it is not hard to conceive that early humans had (at least) a similar sense of more and less. However, our conjectures about how and when these ideas emerged among humans are simply that; educated guesses based on our own assumptions of what might or could have been.

The Need for Simple Counting

As societies and humankind evolved, simply having a sense of more or less, even or odd, etc., would prove to be insufficient to meet the needs of everyday living. As tribes and groups formed, it became important to be able to know how many members were in the group, and perhaps how many were in the enemy's camp. And certainly it was important for them to know if the flock of sheep or other possessed animals were increasing or decreasing in size. "Just how many of them do we have, anyway?" is a question that we do not have a hard time imagining them asking themselves (or each other).

In order to count items such as animals, it is often conjectured that one of the earliest methods of doing so would be with "tally sticks." These are objects used to track the numbers of items to be counted. With this method, each "stick" (or pebble, or whatever counting device being used) represents one animal or object. This method uses the idea of *one to one correspondence*. In a one to one correspondence, items that are being counted are uniquely linked with some counting tool.

In the picture to the right, you see each stick corresponding to one horse. By examining the collection of sticks in hand one knows how many animals should be present. You can imagine the usefulness of such a system, at least for smaller numbers of items to keep track of. If a herder wanted to "count off" his animals to make sure they were all present, he could mentally (or methodically) assign each stick to one animal and continue to do so until he was satisfied that all were accounted for.

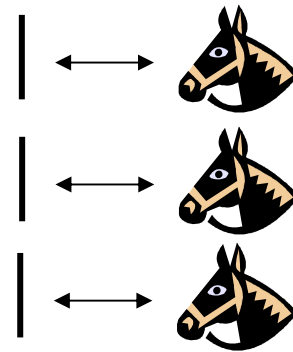

Of course, in our modern system, we have replaced the sticks with more abstract objects. In particular, the top stick is replaced with our symbol "1," the second stick gets replaced by a "2" and the third stick is represented by the symbol "3." But we are getting ahead of ourselves here. These modern symbols took many centuries to emerge.

Another possible way of employing the "tally stick" counting method is by making marks or cutting notches into pieces of wood, or even tying knots in string (as we shall see later). In 1937, Karl Absalom discovered a wolf bone that goes back possibly 30,000 years. It is believed to be a counting device.⁴ Another example of this kind of tool is the Ishango Bone, discovered in 1960 at Ishango, and shown below.⁵ It is reported to be between six and nine thousand years old and shows what appear to be markings used to do counting of some sort.

The markings on rows (a) and (b) each add up to 60. Row (b) contains the prime numbers between 10 and 20. Row (c) seems to illustrate for the method of doubling and multiplication used by the Egyptians (which we will study in the next topic). It is believed that this may also represent a lunar phase counter.

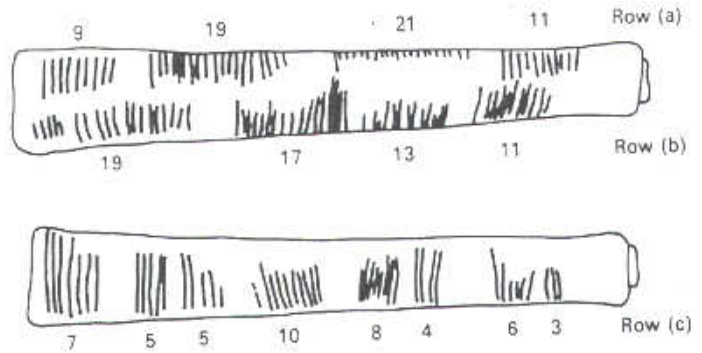

Spoken Words

As methods for counting developed, and as language progressed as well, it is natural to expect that spoken words for numbers would appear. Unfortunately, the development of these words, especially those for our numbers corresponding from one through ten, are not easy to trace. Past ten, however, we do see some patterns:

Eleven comes from “ein lifon,” meaning “one left over.”

Twelve comes from “twe lif,” meaning “two left over.”

Thirteen comes from “Three and ten” as do fourteen through nineteen.

Twenty appears to come from “twe–tig” which means “two tens.”

Hundred probably comes from a term meaning “ten times.”

Written Numbers

When we speak of “written” numbers, we have to be careful because this could mean a variety of things. It is important to keep in mind that modern paper is only a little more than 100 years old, so “writing” in times past often took on forms that might look quite unfamiliar to us today.

As we saw earlier, some might consider wooden sticks with notches carved in them as writing as these are means of recording information on a medium that can be “read” by others. Of course, the symbols used (simple notches) certainly did not leave a lot of flexibility for communicating a wide variety of ideas or information.

Other mediums on which “writing” may have taken place include carvings in stone or clay tablets, rag paper made by hand (12th century in Europe, but earlier in China), papyrus (invented by the Egyptians and used up until the Greeks), and parchments from animal skins. And these are just a few of the many possibilities.

These are just a few examples of early methods of counting and simple symbols for representing numbers. Extensive books, articles and research have been done on this topic and could provide enough information to fill this entire course if we allowed it to. The range and diversity of creative thought that has been used in the past to describe numbers and to count objects and people is staggering. Unfortunately, we don’t have time to examine them all, but it is fun and interesting to look at one system in more detail to see just how ingenious people have been.

The Number and Counting System of the Inca Civilization

Background

There is generally a lack of books and research material concerning the historical foundations of the Americas. Most of the “important” information available concentrates on the eastern hemisphere, with Europe as the central focus. The reasons for this may be twofold: first, it is thought that there was a lack of specialized mathematics in the American regions; second, many of the secrets of ancient mathematics in the Americas have been closely guarded.⁶ The Peruvian system does not seem to be an exception here. Two researchers, Leland Locke and Erland Nordenskiöld, have carried out research that has attempted to discover what mathematical knowledge was known by the Incas and how they used the Peruvian quipu, a counting system using cords and knots, in their mathematics. These researchers have come to certain beliefs about the quipu that we will summarize here.

Counting Boards

It should be noted that the Incas did not have a complicated system of computation. Where other peoples in the regions, such as the Mayans, were doing computations related to their rituals and calendars, the Incas seem to have been more concerned with the simpler task of record-keeping. To do this, they used what are called the “quipu” to record quantities of items. (We will describe them in more detail in a moment.) However, they first often needed to do computations whose results would be recorded on quipu. To do these computations, they would sometimes use a counting board constructed with a slab of stone. In the slab were cut rectangular and square compartments so that an octagonal (eight-sided) region was left in the middle. Two opposite corner rectangles were raised. Another two sections were mounted on the original surface of the slab so that there were actually three levels available. In the figure shown, the darkest shaded corner regions represent the highest, third level. The lighter shaded regions surrounding the corners are the second highest levels, while the clear white rectangles are the compartments cut into the stone slab.

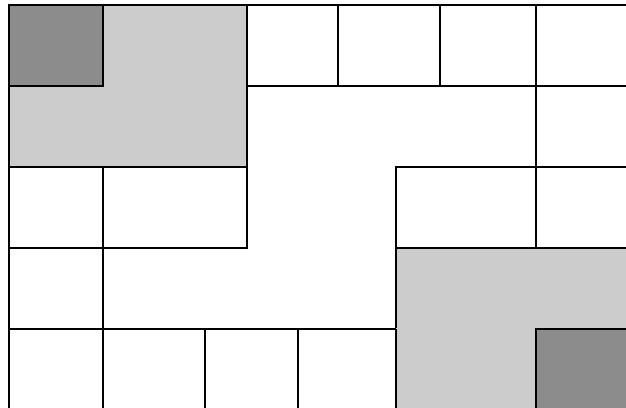

Pebbles were used to keep accounts and their positions within the various levels and compartments gave totals. For example, a pebble in a smaller (white) compartment represented one unit. Note that there are 12 such squares around the outer edge of the figure. If a pebble was put into one of the two (white) larger, rectangular compartments, its value was doubled. When a pebble was put in the octagonal region in the middle of the slab, its value was tripled. If a pebble was placed on the second (shaded) level, its value was multiplied by six. And finally, if a pebble was found on one of the two highest corner levels, its value was multiplied by twelve. Different objects could be counted at the same time by representing different objects by different colored pebbles.

Example 1

Suppose you have the following counting board with two different kind of pebbles places as illustrated. Let the solid black pebble represent a dog and the striped pebble represent a cat. How many dogs are being represented?

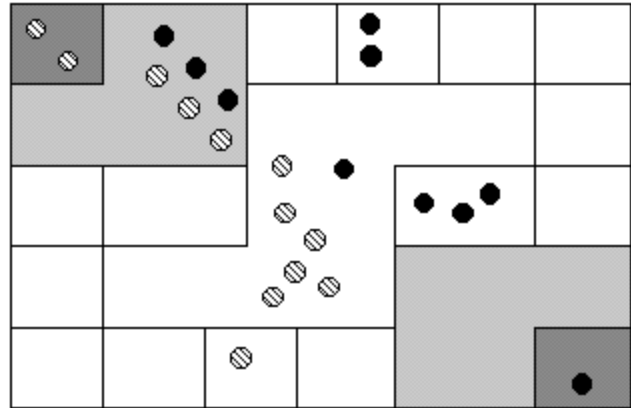

Solution

There are two black pebbles in the outer square regions...these represent 2 dogs.

There are three black pebbles in the larger (white) rectangular compartments. These represent 6 dogs.

There is one black pebble in the middle region...this represents 3 dogs.

There are three black pebbles on the second level...these represent 18 dogs.

Finally, there is one black pebble on the highest corner level...this represents 12 dogs. We then have a total of $2+6+3+18+12 = 41$ dogs. ♦

CheckPoint A

How many cats are represented on this board? See endnotes for the solution.⁷

The Quipu

This kind of board was good for doing quick computations, but it did not provide a good way to keep a permanent recording of quantities or computations. For this purpose, they used the quipu. The quipu is a collection of cords with knots in them. These cords and knots are carefully arranged so that the position and type of cord or knot gives specific information on how to decipher the cord.

A quipu is made up of a main cord which has other cords (branches) tied to it. See pictures to the right.⁸

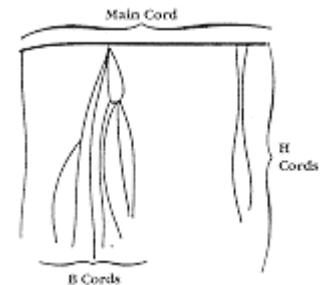

Locke called the branches H cords. They are attached to the main cord. B cords, in turn, were attached to the H cords. Most of these cords would have knots on them. Rarely are knots found on the main cord, however, and tend to be mainly on the H and B cords. A quipu might also have a “totalizer” cord that summarizes all of the information on the cord group in one place.

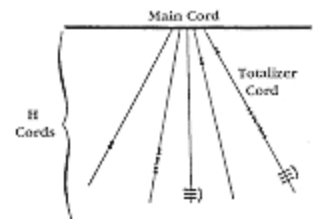

Locke points out that there are three types of knots, each representing a different value, depending on the kind of knot used and its position on the cord. The Incas, like us, had a

decimal (base-ten) system, so each kind of knot had a specific decimal value. The Single knot, pictured in the middle of the diagram⁹ was used to denote tens, hundreds, thousands, and ten thousands. They would be on the upper levels of the H cords. The figure-eight knot on the end was used to denote the integer “one.” Every other integer from 2 to 9 was represented with a long knot, shown on the left of the figure. (Sometimes long knots were used to represent tens and hundreds.) Note that the long knot has several turns in it...the number of turns indicates which integer is being represented. The units (ones) were placed closest to the bottom of the cord, then tens right above them, then the hundreds, and so on.

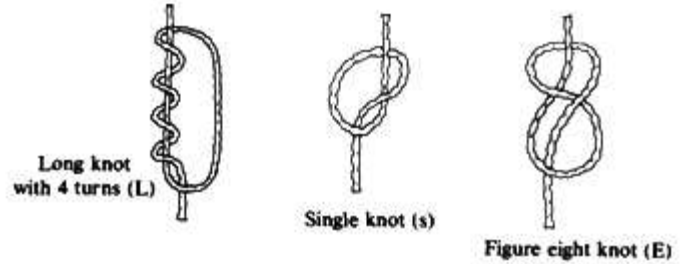

In order to make reading these pictures more easy, we will adopt a convention that is consistent. For the long knot with turns in it (representing the numbers 2 through 9), we will use the following notation:



The four horizontal bars represent four turns and the curved arc on the right links the four turns together. This would represent the number 4.

We will represent the single knot with a large dot (•) and we will represent the figure eight knot with the a sideways eight (∞).

Example 2

What number is represented on the cord shown?

Solution

On the cord, we see a long knot with four turns in it...this represents four in the ones place. Then 5 single knots appear in the tens position immediately above that, which represents 5 tens, or 50. Finally, 4 single knots are tied in the hundreds, representing four 4 hundreds, or 400. Thus, the total shown on this cord is 454. ♦

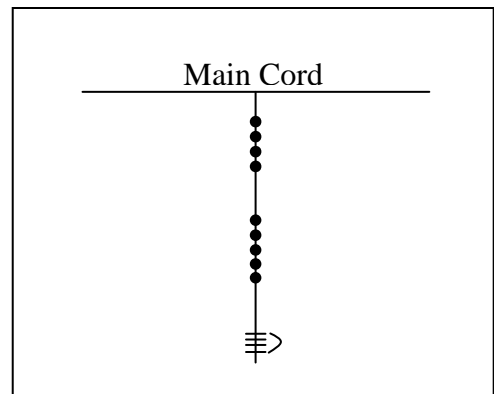

CheckPoint B

What numbers are represented on each of the four cords hanging from the main cord?

Answer:

- From left to right:
- Cord 1 = 2,162
- Cord 2 = 301
- Cord 3 = 0
- Cord 4 = 2,070 ♦

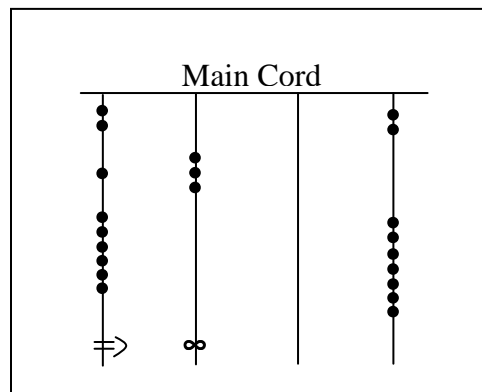

The colors of the cords had meaning and could distinguish one object from another. One color could represent llamas, while a different color might represent sheep, for example. When all the colors available were exhausted, they would have to be re-used. Because of this, the ability to read the quipu became a complicated task and specially trained individuals did this job. They were called Quipucamayoc, which means keeper of the quipus. They would build, guard, and decipher quipus.

As you can see from this photograph of an actual quipu, they could get quite complex.

There were various purposes for the quipu. Some believe that they were used to keep an account of their traditions and history, using knots to record history rather than some other formal system of writing. One writer has even suggested that the quipu replaced writing as it formed a role in the Incan postal system.¹⁰ Another proposed use of the quipu is as a translation tool. After the conquest of the Incas by the Spaniards and subsequent “conversion” to Catholicism, an Inca supposedly could use the quipu to confess their sins to a priest. Yet another proposed use of the quipu was to record numbers related to magic and astronomy, although this is not a widely accepted interpretation.

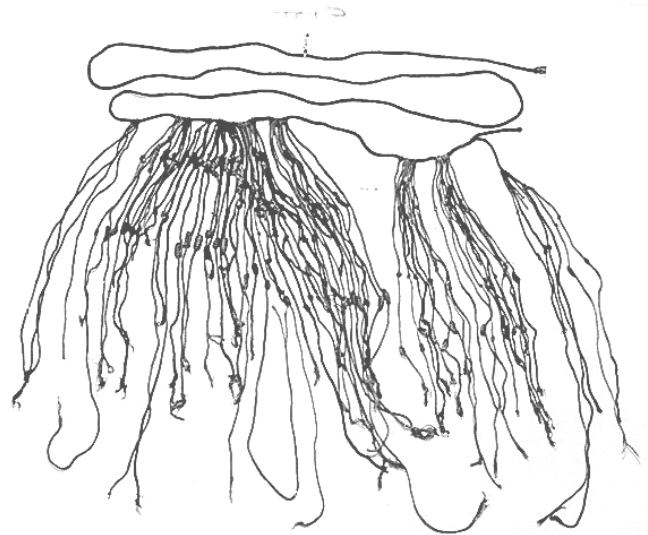

The mysteries of the quipu have not been fully explored yet. Recently, Ascher and Ascher have published a book, *The Code of the Quipu: A Study in Media, Mathematics, and Culture*, which is “an extensive elaboration of the logical-numerical system of the quipu.”¹¹ For more information on the quipu, you may want to check out the following Internet link:

<http://www.anthropology.wisc.edu/salomon/Chaysimire/khipus.php>

We are so used to seeing the symbols 1, 2, 3, 4, etc. that it may be somewhat surprising to see such a creative and innovative way to compute and record numbers. Unfortunately, as we proceed through our mathematical education in grade and high school, we receive very little information about the wide range of number systems that have existed and which still exist all over the world. That’s not to say our own system is not important or efficient. The fact that it has survived for hundreds of years and shows no sign of going away any time soon suggests that we may have finally found a system that works well and may not need further improvement. But only time will tell that whether or not that conjecture is valid or not. We now turn to a brief historical look at how our current system developed over history.

The Hindu – Arabic Number System

The Evolution of a System

Our own number system, composed of the ten symbols {0,1,2,3,4,5,6,7,8,9} is called the *Hindu–Arabic system*. This is a base–ten (decimal) system since place values increase by powers of ten. Furthermore, this system is positional, which means that the position of a symbol has bearing on the value of that symbol within the number. For example, the position of the symbol 3 in the number 435,681 gives it a value much greater than the value of the symbol 8 in that same number. (We'll explore base systems more thoroughly later.) The development of these ten symbols and their use in a positional system comes to us primarily from India.¹²

It was not until the 15th century that the symbols that we are familiar with today first took form in Europe. However, the history of these numbers and their development goes back hundreds of years. One important source of information on this topic is the writer al–Biruni, whose picture is shown here.¹³ Al–Biruni, who was born in modern day Uzbekistan, had visited India on several occasions and made comments on the Indian number system. When we look at the origins of the numbers that al–Biruni encountered, we have to go back to the third century B.C.E. to explore their origins. It is then that the Brahmi numerals were being used.



The Brahmi numerals were more complicated than those used in our own modern system. They had separate symbols for the numbers 1 through 9, as well as distinct symbols for 10, 100, 1000, ..., also for 20, 30, 40, ..., and others for 200, 300, 400, ..., 900. The Brahmi symbols for 1, 2, and 3 are shown below.¹⁴

1	2	3
—	=	≡

Brahmi one, two, three

These numerals were used all the way up to the 4th century C.E., with variations through time and geographic location. For example, in the first century C.E., one particular set of Brahmi numerals took on the following form¹⁵:

1	2	3	4	5	6	7	8	9
—	=	≡	+	h	4	7	5	7

From the 4th century on, you can actually trace several different paths that the Brahmi numerals took to get to different points and incarnations. One of those paths led to our current numeral system, and went through what are called the Gupta numerals. The Gupta numerals were prominent during a time ruled by the Gupta dynasty and were spread throughout that empire as they conquered lands during the 4th through 6th centuries. They have the following form¹⁶:

1	2	3	4	5	6	7	8	9
—	=	≡	𑀓	𑀔	𑀕	𑀖	𑀗	𑀘

How the numbers got to their Gupta form is open to considerable debate. Many possible hypotheses have been offered, most of which boil down to two basic types¹⁷. The first type of hypothesis states that the numerals came from the initial letters of the names of the numbers. (This is not uncommon...the Greek numerals developed in this manner.) The second type of hypothesis states that they were derived from some earlier number system. However, there are other hypotheses that are offered, one of which is by the researcher Ifrah. His theory is that there were originally nine numerals, each represented by a corresponding number of vertical lines. One possibility is this:¹⁸

1	2	3	4	5	6	7	8	9
I	II	III	II II	III II	III III	III III	III III	III III

Because these symbols would have taken a lot of time to write, they eventually evolved into cursive symbols that could be written more quickly. If we compare these to the Gupta numerals above, we can try to see how that evolutionary process might have taken place, but our imagination would be just about all we would have to depend upon since we do not know exactly how the process unfolded.

The Gupta numerals eventually evolved into another form of numerals called the Nagari numerals, and these continued to evolve until the 11th century, at which time they looked like this:¹⁹

1	2	3	4	5	6	7	8	9	0
१	२	३	४	५	६	७	८	९	०

Note that by this time, the symbol for 0 has appeared! (The Mayans in the Americas had a symbol for zero long before this, however, as we shall see later in the chapter.)

These numerals were adopted by the Arabs, most likely in the eighth century during Islamic incursions into the northern part of India.²⁰ It is believed that the Arabs were instrumental in spreading them to other parts of the world, including Spain (see below).

Other examples of variations up to the eleventh century include:

Devangari, eighth century²¹:



West Arab Gobar, tenth century²²:



Spain, 976 B.C.E.²³:



Finally, one more graphic²⁴ shows various forms of these numerals as they developed and eventually converged to the 15th century in Europe.

The Positional System

More important than the form of the number symbols is the development of the place value system. Although it is in slight dispute, the earliest known document in which the Indian system displays a positional system dates back to 346 C.E. However, some evidence suggests that they may have actually developed a positional system as far back as the first century C.E.

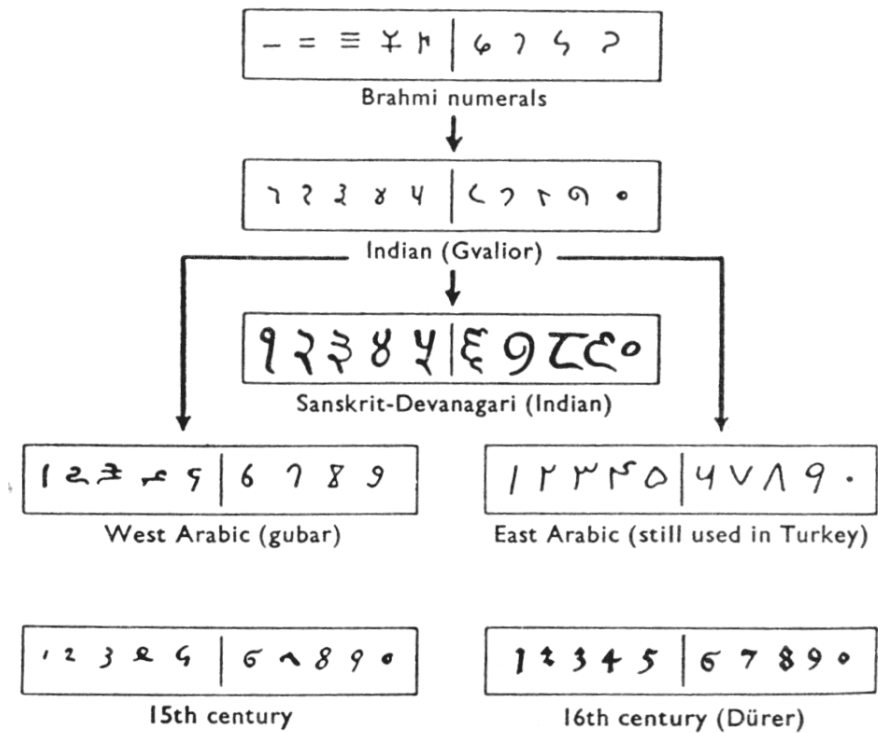

The Indians were not the first to use a positional system. The Babylonians (as we will see in Chapter 3) used a positional system with 60 as their base. However, there is not much evidence that the Babylonian system had much impact on later numeral systems, except with the Greeks. Also, the Chinese had a base-10 system, probably derived from the use of a counting board²⁵. Some believe that the positional system used in India was derived from the Chinese system.

Wherever it may have originated, it appears that around 600 C.E., the Indians abandoned the use of symbols for numbers higher than nine and began to use our familiar system where the position of the symbol determines its overall value.²⁶ Numerous documents from the seventh century demonstrate the use of this positional system.

Interestingly, the earliest dated inscriptions using the system with a symbol for zero come from Cambodia. In 683, the 605th year of the Saka era is written with three digits and a dot in the middle. The 608th year uses three digits with a modern 0 in the middle.²⁷ The dot as a symbol for zero also appears in a Chinese work (*Chiu-chih li*). The author of this document gives a strikingly clear description of how the Indian system works:

Using the [Indian] numerals, multiplication and division are carried out. Each numeral is written in one stroke. When a number is counted to ten, it is advanced into the higher place. In each vacant place a dot is always put. Thus the numeral is always denoted in each place. Accordingly there can be no error in determining the place. With the numerals, calculations is easy... ”²⁸

Transmission to Europe

It is not completely known how the system got transmitted to Europe. Traders and travelers of the Mediterranean coast may have carried it there. It is found in a tenth-century Spanish manuscript and may have been introduced to Spain by the Arabs, who invaded the region in 711 C.E. and were there until 1492.

In many societies, a division formed between those who used numbers and calculation for practical, every day business and those who used them for ritualistic purposes or for state business.²⁹ The former might often use older systems while the latter were inclined to use the newer, more elite written numbers. Competition between the two groups arose and continued for quite some time. In a 14th century manuscript of Boethius’ *The Consolations of Philosophy*, there appears a well-known drawing of two mathematicians. One is a merchant and is using an abacus (the “abacist”). The other is a Pythagorean philosopher (the “algorist”) using his “sacred” numbers. They are in a competition that is being judged by the goddess of number. By 1500 C.E., however, the newer symbols and system had won out and has persevered until today. The Seattle Times recently reported that the Hindu–Arabic numeral system has been included in the book *The Greatest Inventions of the Past 2000 Years*.³⁰



One question to answer is *why* the Indians would develop such a positional notation. Unfortunately, an answer to that question is not currently known. Some suggest that the system has its origins with the Chinese counting boards. These boards were portable and it is thought that Chinese travelers who passed through India took their boards with them and

ignited an idea in Indian mathematics.³¹ Others, such as G. G. Joseph propose that it is the Indian fascination with very large numbers that drove them to develop a system whereby these kinds of big numbers could easily be written down. In this theory, the system developed entirely within the Indian mathematical framework without considerable influence from other civilizations.

The Development and Use of Different Number Bases

Introduction and Basics

During the previous discussions, we have been referring to positional base systems. In this section of the chapter, we will explore exactly what a base system is and what it means if a system is “positional.” We will do so by first looking at our own familiar, base-ten system and then deepen our exploration by looking at other possible base systems. In the next part of this section, we will journey back to Mayan civilization and look at their unique base system, which is based on the number 20 rather than the number 10.

A base system is a structure within which we count. The easiest way to describe a base system is to think about our own base-ten system. The base-ten system, which we call the “decimal” system, requires a total of ten different symbols/digits to write any number. They are, of course, 0, 1, 2, 9.

The decimal system is also an example of a *positional* base system, which simply means that the position of a digit gives its place value. Not all civilizations had a positional system even though they did have a base with which they worked.

In our base-ten system, a number like 5,783,216 has meaning to us because we are familiar with the system and its places. As we know, there are six ones, since there is a 6 in the ones place. Likewise, there are seven “hundred thousands,” since the 7 resides in that place. Each digit has a value that is explicitly determined by its position within the number. (We make a distinction between digit, which is just a symbol such as 5, and a number, which is made up of one or more digits.) We can take this number and assign each of its digits a value. One way to do this is with a table, which follows:

5,000,000	= $5 \times 1,000,000$	= 5×10^6	Five million
+700,000	= $7 \times 100,000$	= 7×10^5	Seven hundred thousand
+80,000	= $8 \times 10,000$	= 8×10^4	Eighty thousand
+3,000	= 3×1000	= 3×10^3	Three thousand
+200	= 2×100	= 2×10^2	Two hundred
+10	= 1×10	= 1×10^1	Ten
+6	= 6×1	= 6×10^0	Six
5,783,216	Five million, seven hundred eighty-three thousand, two hundred sixteen		

From the third column in the table we can see that each place is simply a multiple of ten. Of course, this makes sense given that our base is ten. The digits that are multiplying each place simply tell us how many of that place we have. We are restricted to having at most 9 in any

one place before we have to “carry” over to the next place. We cannot, for example, have 11 in the hundred–thousands place. Instead, we would carry 1 to the millions place and retain 1 in the hundred–thousands place. This comes as no surprise to us since we readily see that 11 hundred–thousands is the same as one million, one hundred thousand. Carrying is a pretty typical occurrence in a base system.

However, base-ten is not the only option we have. Practically any positive integer greater than or equal to 2 can be used as a base for a number system. Such systems can work just like the decimal system except the number of symbols will be different and each position will depend on the base itself.

Other Bases

For example, let’s suppose we adopt a base–five system. The only modern digits we would need for this system are 0,1,2,3 and 4. What are the place values in such a system? To answer that, we start with the ones place, as most base systems do. However, if we were to count in this system, we could only get to four (4) before we had to jump up to the next place. Our base is 5, after all! What is that next place that we would jump to? It would not be tens, since we are no longer in base–ten. We’re in a different numerical world. As the base–ten system progresses from 10^0 to 10^1 , so the base–five system moves from 5^0 to $5^1 = 5$. Thus, we move from the ones to the fives. After the fives, we would move to the 5^2 place, or the twenty fives. (Note that in base–ten, we would have gone from the tens to the hundreds, which is, of course, 10^2 .)

Let’s take an example and build a table. Consider the number 30412 in base five. We will write this as 30412_5 , where the subscript 5 is not part of the number but indicates the base we’re using. First off, note that this is NOT the number

	Base 5	This column covert to base–ten	In Base–Ten
	3×5^4	$= 3 \times 625$	$= 1875$
+	0×5^3	$= 0 \times 125$	$= 0$
+	4×5^2	$= 4 \times 25$	$= 100$
+	1×5^1	$= 1 \times 5$	$= 5$
+	2×5^0	$= 2 \times 1$	$= 2$
		Total	1982

“thirty thousand, four hundred twelve.” We must be careful not to impose the base–ten system on this number. Here’s what our table might look like. We will use it to convert this number to our more familiar base–ten system.

As you can see, the number 30412_5 is equivalent to 1,982 in base–ten. We will say $30412_5 = 1982_{10}$. All of this may seem strange to you, but that’s only because you are so used to the only system that you’ve ever seen.

Example 3

Convert 6234_7 to a base 10 number.

Solution

We first note that we are given a base-7 number that we are to convert. Thus, our places will start at the ones (7^0), and then move up to the 7's, 49's (7^2), etc. Here's the breakdown:

	Base 7	Convert	Base 10
	$= 6 \times 7^3$	$= 6 \times 343$	$= 2058$
+	$= 2 \times 7^2$	$= 2 \times 49$	$= 98$
+	$= 3 \times 7$	$= 3 \times 7$	$= 21$
+	$= 4 \times 1$	$= 4 \times 1$	$= 4$
		Total	2181

Thus $6234_7 = 2181_{10}$. ♦

CheckPoint C

Convert 41065_7 to a base 10 number. See endnotes for the answer.³²

Converting from Base 10 to Other Bases

Converting from an unfamiliar base to the familiar decimal system is not that difficult once you get the hang of it. It's only a matter of identifying each place and then multiplying each digit by the appropriate power. However, going the other direction can be a little trickier. Suppose you have a base-ten number and you want to convert to base-five. Let's start with some simple examples before we get to a more complicated one.

Example 4

Convert twelve to a base-five number.

Solution:

We can probably easily see that we can rewrite this number as follows:

$$12 = (2 \times 5) + (2 \times 1)$$

Hence, we have two fives and 2 ones. Hence, in base-five we would write twelve as 22_5 . Thus, $12_{10} = 22_5$ ♦

Example 5

Convert sixty-nine to a base-five number. We can see now that we have more than 25, so we rewrite sixty-nine as follows:

$$69 = (2 \times 25) + (3 \times 5) + (4 \times 1)$$

Solution

Here, we have two twenty-fives, 3 fives, and 4 ones. Hence, in base five we have 234_5 . Thus, $69_{10} = 234_5$. ♦

Example 6

Convert the base–seven number 3261_7 to base 10.

Solution

The powers of 7 are:

$$\begin{aligned} 7^0 &= 1 \\ 7^1 &= 7 \\ 7^2 &= 49 \\ 7^3 &= 343 \\ &\text{Etc...} \end{aligned}$$

$$3261_7 = (3 \times 343) + (2 \times 49) + (6 \times 7) + (1 \times 1) = 1170_{10}. \text{ Thus } 3261_7 = 1170_{10}. \blacklozenge$$

CheckPoint D

Convert 143 to base 5. See the footnotes for solution.³³

CheckPoint E

Convert the base–three number 21021_3 to base 10. See the endnotes for the solution.³⁴

In general, when converting from base–ten to some other base, it is often helpful to determine the highest power of the base that will divide into the given number at least once. In the last example, $5^2 = 25$ is the largest power of five that is present in 69, so that was our starting point. If we had moved to $5^3 = 125$, then 125 would not divide into 69 at least once.

Example 7

Convert the base–ten number 348 to base–five.

Solution

The powers of five are:

$$\begin{aligned} 5^0 &= 1 \\ 5^1 &= 5 \\ 5^2 &= 25 \\ 5^3 &= 125 \\ 5^4 &= 625 \\ &\text{Etc...} \end{aligned}$$

Since 348 is smaller than 625, but bigger than 125, we see that $5^3 = 125$ is the highest power of five present in 348. So we divide 125 into 348 to see how many of them there are:

$$348 \div 125 = 2 \text{ with remainder } 98$$

There are 98 left over, so we see how many 25's (the next smallest power of five) there are in the remainder:

$$98 \div 25 = 3 \text{ with remainder } 23$$

There are 23 left over, so we look at the next place, the 5's:

$$23 \div 5 = 4 \text{ with remainder } 3$$

This leaves us with 3 ones, and we are ready to assemble our base-five number:

$$348 = (2 \times 5^3) + (3 \times 5^2) + (4 \times 5^1) + (3 \times 1)$$

Hence, our base-five number is **2343**. We'll say that $348_{10} = 2343_5$. ♦

Example 8

Convert the base-ten number 4,509 to base-seven.

Solution

The powers of 7 are:

$$\begin{aligned} 7^0 &= 1 \\ 7^1 &= 7 \\ 7^2 &= 49 \\ 7^3 &= 343 \\ 7^4 &= 2401 \\ 7^5 &= 16807 \\ &\text{Etc...} \end{aligned}$$

The highest power of 7 that will divide evenly into 4,509 is $7^4 = 2401$. With division, we see that it will go in 1 time with a remainder of 2108. So we have 1 in the 7^4 place. The next power down is $7^3 = 343$, which goes into 2108 six times with a new remainder of 50. So we have 6 in the 7^3 place.

The next power down is $7^2 = 49$, which goes into 50 once with a new remainder of 1. So there is a 1 in the 7^2 place. The next power down is 7^1 but there was only a remainder of 1, so that means there is a 0 in the 7^1 's place and we still have 1 as a remainder. That, of course, means that we have 1 in the ones place. Putting all of this together means that $4,509_{10} = 16101_7$. ♦

$4,509 \div 7^4 =$	1 R 2108
$2108 \div 7^3 =$	6 R 50
$50 \div 7^2 =$	1 R 1
$1 \div 7^1 =$	0 R 1
$1 \div 7^0 =$	1
$4,509_{10} =$ 16101 ₇	

CheckPoint F

Convert 657_{10} to a base 4 number. See endnotes for the answer.³⁵

CheckPoint G

Convert 8377_{10} to a base 8 number. See endnotes for the answer.³⁶

A New Method For Converting From Base 10 to Other Bases

As you read the solution to this last example and attempted the “You Try It” problems, you may have had to repeatedly stop and think about what was going on. The fact that you are probably struggling to follow the explanation and reproduce the process yourself is mostly due to the fact that the non-decimal systems are so unfamiliar to you. In fact, the only system that you are probably comfortable with is the decimal system. As budding mathematicians, you should always be asking questions like “How could I simplify this process?” In general,

that is one of the main things that mathematicians do...they look for ways to take complicated situations and make them easier or more familiar. In this section we will attempt to do that.

To do so, we will start by looking at our own decimal system. What we do may seem obvious and maybe even intuitive but that's the point. We want to find a process that we readily recognize works and makes sense to us in a familiar system and then use it to extend our results to a different, unfamiliar system.

Let's start with the decimal number, 4863_{10} . We will convert this number to base 10. (Yeah, I know it's already in base 10, but if you carefully follow what we're doing, you'll see it makes things work out very nicely with other bases later on.) We first note that the highest power of 10 that will divide into 4863 at least once is $10^3 = 1000$. *In general, this is the first step in our new process; we find the highest power that a given base that will divide at least once into our given number.*

We now divide 1000 into 4863:

$$4863 \div 1000 = 4.863$$

This says that there are four thousands in 4863 (obviously). However, it also says that there are 0.863 thousands in 4863. This fractional part is our remainder and will be converted to lower powers of our base (10). If we take that decimal and multiply by 10 (since that's the base we're in) we get the following:

$$0.863 \times 10 = 8.63$$

Why multiply by 10 at this point? We need to recognize here that 0.863 thousands is the same as 8.63 hundreds. Think about that until it sinks in.

$$(0.863)(1000) = 863$$

$$(8.63)(100) = 863$$

These two statements are equivalent. So, what we are really doing here by multiplying by 10 is rephrasing or converting from one place (thousands) to the next place down (hundreds).

$$0.863 \times 10 \Rightarrow 8.63$$

$$(\text{Parts of Thousands}) \times 10 \Rightarrow \text{Hundreds}$$

What we have now is 8 hundreds and a remainder of 0.63 hundreds, which is the same as 6.3 tens. We can do this again with the 0.63 that remains after this first step.

$$0.63 \times 10 \Rightarrow 6.3$$

$$\text{Hundreds} \times 10 \Rightarrow \text{Tens}$$

So we have six tens and 0.3 tens, which is the same as 3 ones, our last place value.

Now here's the punch line. Let's put all of the together in one place:

$$\begin{array}{r}
 4863 \div 10 = \textcircled{4}.863 \\
 \downarrow \\
 0.863 \times 10 = \textcircled{8}.63 \\
 \downarrow \\
 0.63 \times 10 = \textcircled{6}.3 \\
 \downarrow \\
 0.3 \times 10 = \textcircled{3}.0
 \end{array}$$

Note that in each step, the remainder is carried down to the next step and multiplied by 10, the base. Also, at each step, the whole number part, which is circled, gives the digit that belongs in that particular place. What is amazing is that this works for any base! So, to convert from a base 10 number to some other base, b , we have the following steps we can follow:

Converting from Base 10 to Base b

1. Find the highest power of the base b that will divide into the given number at least once and then divide.
2. Keep the whole number part, and multiply the fractional part by the base b .
3. Repeat step two, keeping the whole number part (including 0), carrying the fractional part to the next step until only a whole number result is obtained.
4. Collect all your whole number parts to get your number in base b notation.

We will illustrate this procedure with some examples.

Example 9

Convert the base 10 number, 348_{10} , to base 5.

Solution

This is actually a conversion that we have done in a previous example. The powers of five are:

$$\begin{array}{l}
 5^0=1 \\
 5^1=5 \\
 5^2=25 \\
 5^3=125 \\
 5^4=625 \\
 \text{Etc...}
 \end{array}$$

The highest power of five that will go into 348 at least once is 5^3 . So we divide by 125 and then proceed.

$$\begin{array}{r}
 348 \div 5^3 = \textcircled{2}.784 \\
 \downarrow
 \end{array}$$

$$\begin{array}{r}
 0.784 \times 5 = \textcircled{3}.92 \\
 \downarrow \\
 0.92 \times 5 = \textcircled{4}0.6 \\
 \downarrow \\
 0.6 \times 5 = \textcircled{3}.0
 \end{array}$$

By keeping all the whole number parts, from top bottom, gives 2343 as our base 5 number. Thus, $2343_5 = 348_{10}$.

We can compare our result with what we saw earlier, or simply check with our calculator, and find that these two numbers really are equivalent to each other. ♦

Example 10

Convert the base 10 number, 3007_{10} , to base 5.

Solution

The highest power of 5 that divides at least once into 3007 is $5^4 = 625$. Thus, we have:

$$\begin{array}{r}
 3007 \div 625 = \textcircled{4}.8112 \\
 0.8112 \times 5 = \textcircled{4}.056 \\
 0.056 \times 5 = \textcircled{0}.28 \\
 0.28 \times 5 = \textcircled{1}0.4 \\
 0.4 \times 5 = \textcircled{2}0.0
 \end{array}$$

This gives us that $3007_{10} = 44012_5$. Notice that in the third line that multiplying by 5 gave us 0 for our whole number part. We don't discard that! The zero tells us that a zero in that place. That is, there are no 5^2 's in this number. ♦

This last example shows the importance of using a calculator in certain situations and taking care to avoid clearing the calculator's memory or display until you get to the very end of the process.

Example 11

Convert the base 10 number, 63201_{10} , to base 7.

Solution

The powers of 7 are:

$$\begin{array}{r}
 7^0 = 1 \\
 7^1 = 7
 \end{array}$$

$$\begin{aligned}
 7^2 &= 49 \\
 7^3 &= 343 \\
 7^4 &= 2401 \\
 7^5 &= 16807 \\
 &\text{etc...}
 \end{aligned}$$

The highest power of 7 that will divide at least once into 63201 is 7^5 . When we do the initial division on a calculator, we get the following:

$$63201 \div 7^5 = 3.760397453$$

The decimal part actually fills up the calculators display and we don't know if it terminates at some point or perhaps even repeats down the road. (It must terminate or repeat since $63201 \div 7^5$ is a rational number.) So if we clear our calculator at this point, we will introduce error that is likely to keep this process from ever ending. To avoid this problem, we leave the result in the calculator and simply subtract 3 from this to get the fractional part all by itself. **DO NOT ROUND OFF!** Subtraction and then multiplication by seven gives:

$$\begin{aligned}
 63201 \div 7^5 &= \textcircled{3}.760397453 \\
 0.760397453 \times 7 &= \textcircled{5}.322782174 \\
 0.322782174 \times 7 &= \textcircled{2}.259475219 \\
 0.259475219 \times 7 &= \textcircled{1}.816326531 \\
 0.816326531 \times 7 &= \textcircled{5}.714285714 \\
 0.714285714 \times 7 &= \textcircled{5}.000000000
 \end{aligned}$$

Yes, believe it or not, that last product is exactly 5, *as long as you don't clear anything out on your calculator*. This gives us our final result: $63201_{10} = 352155_7$. If we round, even to two decimal places in each step, clearing our calculator out at each step along the way, we will get a series of numbers that do not terminate, but begin repeating themselves endlessly. (Try it!) We end up with something that doesn't make any sense, at least not in this context. So be careful to use your calculator cautiously on these conversion problems. ♦

CheckPoint H

Convert the base 10 number, 9352_{10} , to base 5. See endnotes for answer.³⁷

CheckPoint I

Convert the base 10 number, 1500, to base 3. See endnotes for answer.³⁸ Be careful not to clear your calculator on this one. Also, if you're not careful in each step, you may not get all of the digits you're looking for, so move slowly and with caution.

The Mayan Numeral System

Background

As you might imagine, the development of a base system is an important step in making the counting process more efficient. Our own base-ten system probably arose from the fact that we have 10 fingers (including thumbs) on two hands. This is a natural development. However, other civilizations have had a variety of bases other than ten. For example, the Natives of Queensland used a base-two system, counting as follows: “one, two, two and one, two two’s, much.” Some Modern South American Tribes have a base-five system counting in this way: “one, two, three, four, hand, hand and one, hand and two,” and so on. The Babylonians used a base-sixty (sexagesimal) system that we will study more in a later chapter. In this chapter, we wrap up with a specific example of a civilization that actually used a base system other than 10.

The Mayan civilization is generally dated from 1500 B.C.E to 1700 C.E. The Yucatan Peninsula (see map³⁹) in Mexico was the scene for the development of one of the most advanced civilizations of the ancient world. The Mayans had a sophisticated ritual system that was overseen by a priestly class. This class of priests developed a philosophy with time as divine and eternal.⁴⁰ The calendar, and calculations related to it, were thus very important to the ritual life of the priestly class, and hence the Mayan people. In fact, much of what we know about this culture comes from their calendar records and astronomy data. (Another important source of information on the Mayans is the writings of Father Diego de Landa, who went to Mexico as a missionary in 1549.)



- | | |
|---------------------------------|--|
| 1. Chichen Itza | 5. Bonampak, Yaxchilan |
| 2. Uxmal | 6. Tikal |
| 3. Tulum | 7. Altun Ha |
| 4. Palenque | 8. Copán |

There were two numeral systems developed by the Mayans – one for the common people and one for the priests. Not only did these two systems use different symbols, they also used different base systems. For the priests, the number system was governed by ritual. The days of the year were thought to be gods, so the formal symbols for the days were decorated heads.⁴¹ (See sample left⁴²) Since the basic calendar was based on 360 days, the priestly numeral system used a mixed base system employing multiples of 20 and 360. This makes for a confusing system, the details of which we will skip in this particular course.



The Mayan Number System

Instead, we will focus on the numeration system of the “common” people, which used a more consistent base system. As we stated earlier, the Mayans used a base–20 system, called the “vigesimal” system. Like our system, it is positional, meaning that the position of a numeric symbol indicates its place value. In the following table you can see the place value in its vertical format.⁴³

Powers	Base–Ten Value	Place Name
20^7	12,800,000,000	Hablat
20^6	64,000,000	Alau
20^5	3,200,000	Kinchil
20^4	160,000	Cabal
20^3	8,000	Pic
20^2	400	<i>Bak</i>
20^1	20	Kal
20^0	1	Hun

In order to write numbers down, there were only three symbols needed in this system. A horizontal bar represented the quantity 5, a dot represented the quantity 1, and a special symbol (thought to be a shell) represented zero. The Mayan system may have been the first to make use of zero as a placeholder/number. The first 20 numbers are shown in the table that follows.⁴⁴

Unlike our system, where the ones place starts on the right and then moves to the left, the Mayan systems places the ones on the bottom of a vertical orientation and moves up as the place value increases.

When numbers are written in vertical form, there should never be more than four dots in a single place. When writing Mayan numbers, every group of five dots becomes one bar. Also, there should never be more than three bars in a single place...four bars would be converted to one dot in the next place up. (It’s the same as 10 getting converted to a 1 in the next place up when we carry during addition.)

Example 12

What is the value of this number, which is shown in vertical form?

ooo

ooo

Number	Vertical Form	Number	Vertical Form
0		10	≡
1	o	11	o ≡
2	oo	12	oo ≡
3	ooo	13	ooo ≡
4	oooo	14	oooo ≡
5	≡	15	≡≡
6	o ≡	16	o ≡≡
7	oo ≡	17	oo ≡≡
8	ooo ≡	18	ooo ≡≡
9	oooo ≡	19	oooo ≡≡

Solution

Starting from the bottom, we have the ones place. There are two bars and three dots in this place. Since each bar is worth 5, we have 13 ones when we count the three dots in the ones place. Looking to the place value above it (the twenties places), we see there are three dots so we have three twenties.

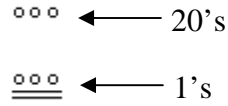

Hence we can write this number in base-ten as:

$$\begin{aligned} (3 \times 20^1) + (13 \times 20^0) &= (3 \times 20) + (13 \times 1) \\ &= 60 + 13 \\ &= 73 \end{aligned}$$

◆

Example 13

What is the value of the following Mayan number?



Solution

This number has 11 in the ones place, zero in the 20's place, and 18 in the $20^2=400$'s place. Hence, the value of this number in base-ten is:

$$18 \times 400 + 0 \times 20 + 11 \times 1 = 7211. \quad \blacklozenge$$

CheckPoint J

Convert the Mayan number below to base 10. See the endnotes for the solution.⁴⁵



Example 14

Convert the base 10 number 3575_{10} to Mayan numerals.

Solution

This problem is done in two stages. First we need to convert to a base 20 number. We will do so using the method provided in the last section of the text. The second step is to convert that number to Mayan symbols.

The highest power of 20 that will divide into 3575 is $20^2 = 400$, so we start by dividing that and then proceed from there:

$$\begin{aligned} 3575 \div 400 &= 8.9375 \\ 0.9375 \times 20 &= 18.75 \\ 0.75 \times 20 &= 15.0 \end{aligned}$$

This means that $3575_{10} = 8,18,15_{20}$

The second step is to convert this to Mayan notation. This number indicates that we have 15 in the ones position. That's three bars at the bottom of the number. We also have 18 in the 20's place, so that's three bars and three dots in the second position. Finally, we have 8 in the 400's place, so that's one bar and three dots on the top. We get the following



◆

NOTE: We are using a new notation here. The commas between the three numbers 8, 18, and 15 are now separating place values for us so that we can keep them separate from each other. This use of the comma is slightly different than how they're used in the decimal system. When we write a number in base 10, such as 7,567,323, the commas are used primarily as an aide to read the number easily but they do not separate single place values from each other. We will need this notation whenever the base we use is larger than 10.

CheckPoint K

Convert the base 10 number 10553_{10} to Mayan numerals. See endnotes for answer.⁴⁶

CheckPoint L

Convert the base 10 number 5617_{10} to Mayan numerals. See endnotes for answer.⁴⁷

Adding Mayan Numbers

When adding Mayan numbers together, we'll adopt a scheme that the Mayans probably did not use but which will make life a little easier for us.

Example 15

Add, in Mayan, the numbers 37 and 29: ⁴⁸

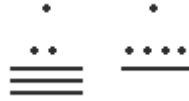

Solution

First draw a box around each of the vertical places. This will help keep the place values from being mixed up.

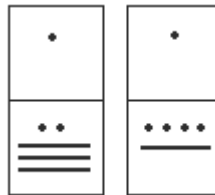

Next, put all of the symbols from both numbers into a single set of places (boxes), and to the right of this new number draw a set of empty boxes where you will place the final sum:



You are now ready to start carrying. Begin with the place that has the lowest value, just as you do with Arabic numbers. Start at the bottom place, where each dot is worth 1. There are six dots, but a maximum of four are allowed in any one place. (Once you get to five dots, you must convert to a bar.) Since five dots make one bar, we draw a bar through five of the dots, leaving us with one dot which is under the four-dot limit. Put this dot into the bottom place of the empty set of boxes you just drew:

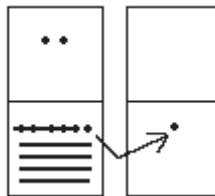

Now look at the bars in the bottom place. There are five, and the maximum number the place can hold is three. *Four bars are equal to one dot in the next highest place.* Whenever we have four bars in a single place we will automatically convert that to a *dot* in the next place up. So we draw a circle

around four of the bars and an arrow up to the dots' section of the higher place. At the end of that arrow, draw a new dot. That dot represents 20 just the same as the other dots in that place. Not counting the circled bars in the bottom place, there is one bar left. One bar is under the three-bar limit; put it under the dot in the set of empty places to the right.

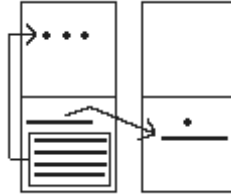

Now there are only three dots in the next highest place, so draw them in the corresponding empty box.

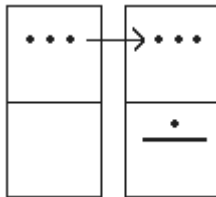

We can see here that we have 3 twenties (60), and 6 ones, for a total of 66. We check and note that $37 + 29 = 66$, so we have done this addition correctly. Is it easier to just do it in base-ten? Probably. But that's only because it's more familiar to you. Your task here is to try to learn a new base system and how addition can be done in slightly different ways than what you have seen in the past. Note, however, that the concept of carrying is still used, just as it is in our own addition algorithm. ♦

Checkpoint M

Try adding 174 and 78 in Mayan by first converting to Mayan numbers and then working entirely within that system. Do not add in base-ten (decimal) until the very end when you *check* your work. A sample solution is shown below, but you should try it on your own before looking at the one given.

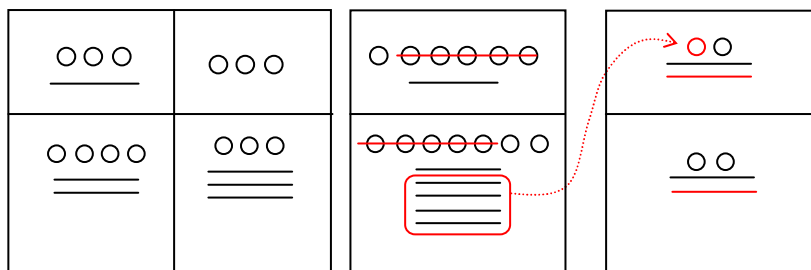

Conclusion

In this first chapter, we have briefly sketched the development of numbers and our counting system, with the emphasis on the “brief” part. There are numerous sources of information and research that fill many volumes of books on this topic. Unfortunately, we cannot begin to come close to covering all of the information that is out there.

We have only scratched the surface of the wealth of research and information that exists on the development of numbers and counting throughout human history. What is important to note is that the system that we use every day is a product of thousands of years of progress and development. It represents contributions by many civilizations and cultures. It does not come down to us from the sky, a gift from the gods. It is not the creation of a textbook publisher. It is indeed as human as we are, as is the rest of mathematics. Behind every symbol, formula and rule there is a human face to be found, or at least sought.

Furthermore, I hope that you now have a basic appreciation for just how interesting and diverse number systems can get. Also, I’m pretty sure that you have also begun to recognize that we take our own number system for granted so much that when we try to adapt to other systems or bases, we find ourselves truly having to concentrate and think about what is going on. This is something that you are likely to experience even more as you study this chapter.

Exercises

Skills



Counting Board And Quipu

- 1) In the following Peruvian counting board, determine how many of each item is represented. Please show all of your calculations along with some kind of explanation of how you got your answer. Note the key at the bottom of the drawing.

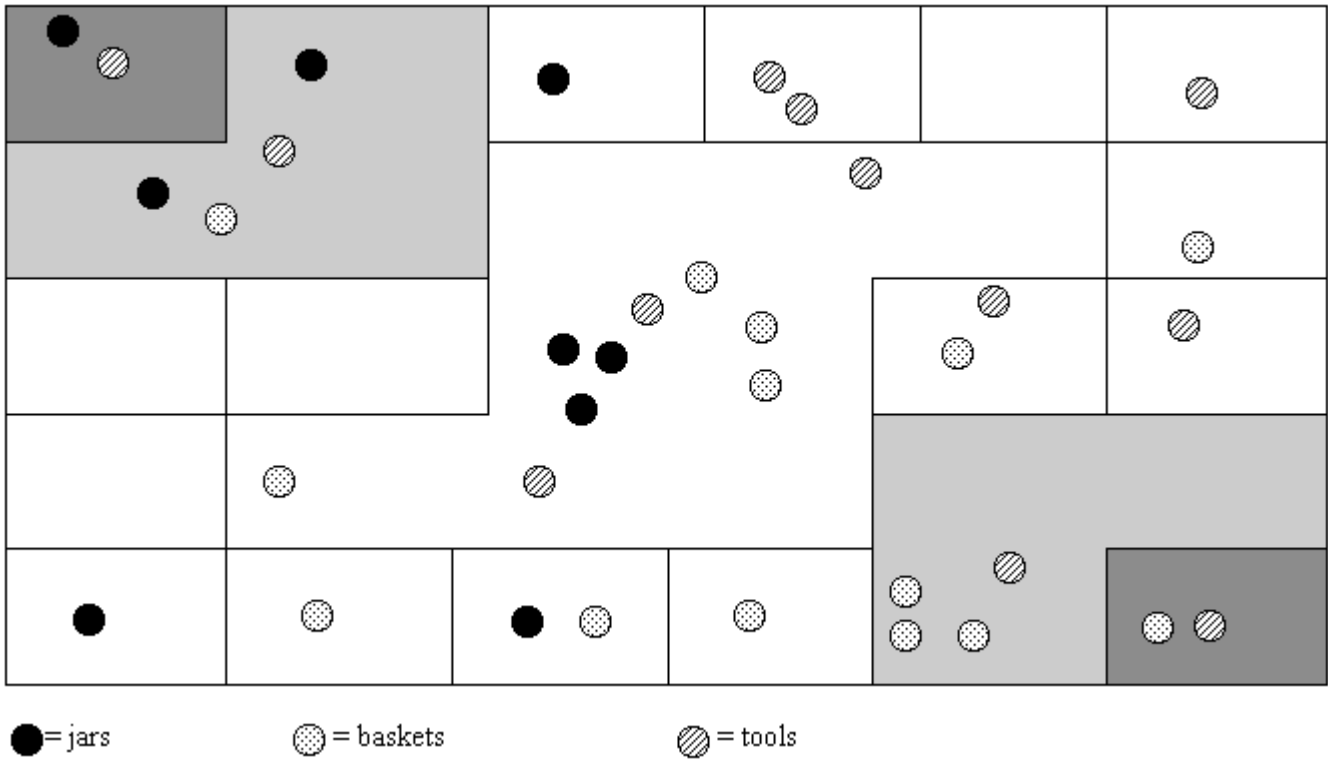

- 2) Draw a quipu with a main cord that has branches (H cords) that show each of the following numbers on them. (You should produce one drawing for this problem with the cord for part **a** on the left and moving to the right for parts **b** through **d**.)
- | | |
|-----------|---------|
| a. 232 | b. 5065 |
| c. 23,451 | d. 3002 |

Basic Base Conversions

- | | |
|--------------------------------|----------------------------------|
| 3) 423 in base 5 to base 10 | 4) 3044 in base 5 to base 10 |
| 5) 387 in base 10 to base 5 | 6) 2546 in base 10 to base 5 |
| 7) 110101 in base 2 to base 10 | 8) 11010001 in base 2 to base 10 |

- 9) 100 in base 10 to base 2
 10) 2933 in base 10 to base 2
 11) Convert 653 in base 7 to base 10.
 12) Convert 653 in base 10 to base 7
 13) 3412 in base 5 to base 2
 14) 10011011 in base 2 to base 5
 (Hint: convert first to base 10 then to the final desired base)

The Caidoz System

Suppose you were to discover an ancient base-12 system made up twelve symbols. Let's call this base system the Caidoz system. Here are the symbols for each of the numbers 0 through 12:

0 = Υ	6 = Ω
1 = Υ	7 = \mathcal{M}
2 = \mathbb{H}	8 = \times^{\wedge}
3 = \mathcal{E}	9 = Υ_{\circ}
4 = \mathcal{Q}	10 = \approx
5 = \mathcal{M}	11 = \mathcal{K}

Convert each of the following numbers in Caidoz to base 10

- 15) $\mathcal{M}\Upsilon\approx$
 16) $\times^{\wedge}\mathcal{E}\Upsilon\mathcal{K}$
 17) $\Omega\mathcal{Q}\mathbb{H}$
 18) $\mathcal{M}\Upsilon\approx\Upsilon$

Convert the following base 10 numbers to Caidoz, using the symbols shown above.

- 19) 175
 20) 3030
 21) 10,000
 22) 5507

Mayan Conversions

Convert the following numbers to Mayan notation. Show your calculations used to get your answers.

- 23) 135
 24) 234
 25) 360
 26) 1,215
 27) 10,500
 28) 1,100,000

Convert the following Mayan numbers to decimal (base-10) numbers. Show all calculations.

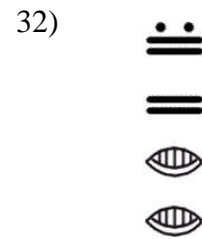
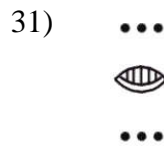
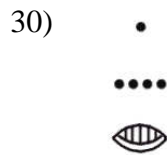
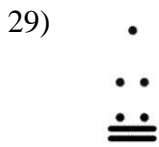

James Bidwell has suggested that Mayan addition was done by “simply combining bars and dots and carrying to the next higher place.” He goes on to say, “After the combining of dots and bars, the second step is to exchange every five dots for one bar in the same position.” After converting the following base 10 numbers into vertical Maya notation (in base 20, of course), perform the indicated addition:

33) $32 + 11$

34) $82 + 15$

35) $35 + 148$

36) $2412 + 5000$

37) $450 + 844$

38) $10,000 + 20,000$

39) $4,500 + 3,500$

40) $130,000 + 30,000$

41) Use the fact that the Mayans had a base-20 number system to complete the following multiplication table. The table entries should be in Mayan notation. Remember: Their zero looked like this... . Xerox and then cut out the table below, fill it in, and paste it onto your homework assignment if you do not want to duplicate the table with a ruler.

(To think about but not write up: Bidwell claims that only these entries are needed for “Mayan multiplication.” What does he mean?)

×	•	••	•••	••••	—	==	===
•							
••							
•••							
••••							
—							
==							
===							

Exploration

Write a short essay on the given topic. It should not be more than one page and if you can type it (double-spaced), I would appreciate it. If you cannot type it, your writing must be legible. Attention to grammar is important, although it does not have to be perfect grammatically...I just want to be able to understand it.

- 42) What are the advantages and disadvantages of bases other than ten.
- 43) Supposed you are charged with creating a base-15 number system. What symbols would you use for your system and why? Explain with at least two specific examples how you would convert between your base-15 system and the decimal system.
- 44) Describe an interesting aspect of Mayan civilization that we did not discuss in class. Your findings must come from some source such as an encyclopedia article, or internet site and you must provide reference(s) of the materials you used (either the publishing information or Internet address).
- 45) For a Papuan tribe in southeast New Guinea, it was necessary to translate the bible passage John 5:5 “And a certain man was there, which had an infirmity 30 and 8 years” into “A man lay ill one man, both hands, five and three years.” Based on your own understanding of bases systems (and some common sense), furnish an explanation of the translation. Please use complete sentences to do so. (Hint: To do this problem, I am asking you to think about how base systems work, where they come from, and how they are used. You won’t necessarily find an “answer” in readings or such...you’ll have to think it through and come up with a reasonable response. Just make sure that you clearly explain why the passage was translated the way that it was.)

Endnotes

- ¹ Eves, Howard; *An Introduction to the History of Mathematics*, p. 9.
- ² Eves, p. 9.
- ³ McLeish, John; *The Story of Numbers – How Mathematics Has Shaped Civilization*, p. 7.
- ⁴ Bunt, Lucas; Jones, Phillip; Bedient, Jack; *The Historical Roots of Elementary Mathematics*, p. 2.
- ⁵ http://www.math.buffalo.edu/mad/Ancient-Africa/mad_zaire-uganda.html
- ⁶ Diana, Lind Mae; The Peruvian Quipu in *Mathematics Teacher*, Issue 60 (Oct., 1967), p. 623–28.
- ⁷ Solution to **CheckpointA**: $1+6\times 3+3\times 6+2\times 12 = 61$ cats.
- ⁸ Diana, Lind Mae; The Peruvian Quipu in *Mathematics Teacher*, Issue 60 (Oct., 1967), p. 623–28.
- ⁹ <http://wiscinfo.doit.wisc.edu/chaysimire/titulo2/kipus/what.htm>
- ¹⁰ Diana, Lind Mae; The Peruvian Quipu in *Mathematics Teacher*, Issue 60 (Oct., 1967), p. 623–28.
- ¹¹ <http://www.cs.uidaho.edu/~casey931/seminar/quipu.html>
- ¹² http://www-groups.dcs.st-and.ac.uk/~history/HistTopics/Indian_numerals.html
- ¹³ <http://www-groups.dcs.st-and.ac.uk/~history/Mathematicians/Al-Biruni.html>
- ¹⁴ http://www-groups.dcs.st-and.ac.uk/~history/HistTopics/Indian_numerals.html
- ¹⁵ http://www-groups.dcs.st-and.ac.uk/~history/HistTopics/Indian_numerals.html
- ¹⁶ Ibid
- ¹⁷ Ibid
- ¹⁸ Ibid
- ¹⁹ Ibid
- ²⁰ Katz, page 230
- ²¹ Burton, David M., *History of Mathematics, An Introduction*, p. 254–255
- ²² Ibid
- ²³ Ibid
- ²⁴ Katz, page 231.
- ²⁵ Ibid, page 230
- ²⁶ Ibid, page 231.
- ²⁷ Ibid, page 232.
- ²⁸ Ibid, page 232.
- ²⁹ McLeish, p. 18
- ³⁰ http://seattletimes.nwsourc.com/news/health-science/html98/invs_20000201.html, Seattle Times, Feb. 1, 2000
- ³¹ Ibid, page 232.
- ³² Solution to **CheckpointC**: $41065_7 = 9994_{10}$
- ³³ Solution to **CheckpointD**: $143_{10} = 1033_5$
- ³⁴ Solution to **CheckpointE**: $21021_3 = 196_{10}$
- ³⁵ Solution to **CheckpointF**: $657_{10} = 22101_4$
- ³⁶ Solution to **CheckpointG**: $8377_{10} = 20271_8$
- ³⁷ Solution to **CheckpointH**: $9352_{10} = 244402_5$
- ³⁸ Solution to **CheckpointI**: $1500_{10} = 2001120_3$
- ³⁹ http://www.gorp.com/gorp/location/latamer/map_maya.htm
- ⁴⁰ Bidwell, James; Mayan Arithmetic in *Mathematics Teacher*, Issue 74 (Nov., 1967), p. 762–68.
- ⁴¹ <http://www.ukans.edu/~lctls/Mayan/numbers.html>
- ⁴² <http://www.ukans.edu/~lctls/Mayan/numbers.html>
- ⁴³ Bidwell
- ⁴⁴ http://www.vpds.wsu.edu/fair_95/gym/UM001.html
- ⁴⁵ Solution to **CheckpointJ**: 1562
- ⁴⁶ Solution to **CheckpointK**: $10553_{10} = 1,6,7,13_{20}$
- ⁴⁷ Solution to **CheckpointL**: $5617_{10} = 14,0,17_{20}$. Note that there is a zero in the 20's place, so you'll need to use the appropriate zero symbol in between the ones and 400's places.
- ⁴⁸ <http://forum.swarthmore.edu/k12/mayan.math/mayan2.html>

